

AM · PM

FN0700V31

INSPIRE V2.0

SPIRIT V2.0

LIKE

SUNNY

GEM



F0750A400

F0750A500

F0770A400

F0770A500

F0780564/22

F0780464/22

F0780964

F0785C900/22

F0785C800/22

F0780064/22

F0790000/22/33

**CHI • DEU • ENG • EST • FRA
LTU • LVA • RUS • UKR**

Inspire V2.0 F0750A400	12, 18, 25, 32, 66
Inspire V2.0 F0750A500	12, 18, 25, 31, 32, 66
Spirit V2.0 F0770A400	13, 19, 34, 66
Spirit V2.0 F0770A500	13, 19, 31, 34, 40, 66
Like F0780564/22	14, 20, 42, 67
Like F0780464/22	14, 21, 49, 67
Like F0780964	15, 22, 55, 67
Sunny F0785C900/22	15, 23, 55, 62, 67
Sunny F0785C800/22	16, 23, 55, 62, 67
Like F0780064/22 / Gem F0790000/22/33	16, 17, 24, 62, 67



安装提示

安装工作只能由专业人员进行。
 安装操作时必须戴手套以免意外划伤。
 安装时需遵守现行的安全规定和安全技术规范（推荐使用德国DIN EN 1717标准）。
 安装龙头之前，须确保冷热水的水压相互平衡。



安全提示！

出现水管冻住时请关闭水阀。

技术参数

工作压强：	最大值 1 MPa
建议工作压强：	0,1 – 0,6 MPa
热水温度：	最大值 75°C
建议热水温度：	65°C
热消毒：	70°C (3 分钟)

本产品仅适用于生活用水。



产品维护与保养

建议定期清洗以避免污渍斑点沉积。
 清理时可选用肥皂液和柔软、略湿的抹布。
 残留的肥皂液、洗发水或沐浴液可能会破坏表面镀层的美观，沾上后要及时用清水冲洗干净。

禁止使用磨料类的工具、膏剂来保养、清洗产品。

为避免表面镀层损坏和变色，禁止使用酸、强碱、丙酮、氯化铵等含腐蚀性成分的化学用品来清洗产品。

本公司保留对产品在设计、构造、产品配套上进行不定期更新升级的权利。

Deutsch



Wichtige Hinweise zur Montage

Es ist zwingend erforderlich die Armaturen ausschließlich durch einen zertifizierten Sanitärfachhandwerker montieren zu lassen.

Wir empfehlen bei der Montage stets das Tragen den Handschuhen, um eventuelle Schnittwunden oder andere Verletzungen zu vermeiden.

Allgemein anerkannte Regeln der Technik sind einzuhalten (insbesondere Beachtung der DIN EN 1717).

Große Druckunterschiede zwischen den Kalt- und Warmwasseranschlüssen müssen ausgeglichen werden.



WARNUNG

Bei Frostgefahr Hausanlage zunächst entleeren.

Technische Daten

Betriebsdruck:	max. 1 MPa
Empfohlener Betriebsdruck:	0,1 – 0,6 MPa
Heißwassertemperatur:	max. 75°C
Empfohlene Heißwassertemperatur:	65°C
Thermische Desinfektion:	70°C (3 min)

Das Produkt ist ausschließlich für Trinkwasser konzipiert.



Pflegehinweis

Zur Vermeidung von Kalkablagerungen auf dem Produkt wird eine regelmäßige Reinigung des Produktes empfohlen. Das Produkt sollte mit einer neutralen Seifenlösung gewaschen, mit Wasser abgespült und mit einem weichen Tuch abgetrocknet werden.

Rückstände von Seife, Shampoo und Duschgel können ebenfalls Schäden auf der Oberfläche verursachen. Solche Rückstände sollten gründlich mit klarem Wasser entfernt werden.

Um Beschädigungen der Oberflächen des Produktes zu vermeiden, dürfen keine Scheuermittel oder Pasten zur Reinigung verwendet werden.

Um Farbveränderungen der Chromoberflächen zu vermeiden, dürfen keine aggressiven chemischen Säuren, Alkalien, Azeton, Ammoniumchlorid oder andere chlorhaltigen Komponenten zur Pflege verwendet werden.

Der Hersteller behält sich ohne Ankündigung das Recht vor, Änderungen der Konstruktion, des Design oder der Zusammenstellung vorzunehmen



Important notes about installation

The product must be fitted exclusively by a specialist sanitary engineer.

To prevent injuries gloves should be worn during installation.

Generally accepted engineering practices should be applied. (In particular, compliance with DIN EN 1717 is recommended).

The hot and cold supplies must be of equal pressures before installation of mixers.



WARNING

Drain system completely if danger of frost.

Technical Data

Operating pressure:	max. 1 MPa
Recommended operating pressure:	0,1 – 0,6 MPa
Hot water temperature:	max. 75°C
Recommended hot water temperature:	65°C
Thermal disinfection:	70°C (3 min)

The product is exclusively designed for drinking water.



Maintenance recommendations

To avoid lime spots at the product it is recommended to be regularly cleaned. The cleaning should be carried out by soap solution with the following rinse with water and removing moisture by dry soft cloth.

Remains of liquid soap, shampoo and shower gel may also cause damages of decorative cover. In case of their penetration onto the diverter housing it should be thoroughly cleaned with clean water

To avoid damages of product surface it is forbidden to use abrasive solutions and pastes for its cleaning.

To avoid changes color of decorative cover it is forbidden to use chemicals for cleaning that contain aggressive chemical substances of acids, alkali, ammonium chloride and other components containing chlorine.

Producer reserves the right without prior notice to introduce alterations into design and component parts of devices.

Tähtis teave paigaldamise kohta

Toote peab paigaldama kvalifitseeritud spetsialist. Vigastuste vältimiseks soovitatakse kanda kaitsekindaid. Paigaldamisel tuleb kasutada üldtunnustatud tehnilisi lahendusi vastavalt kehtivatele normidele (soovitatakse vastavust DIN EN 1717 normidele). Enne segisti paigaldamist tuleb võrdsustada külma ja kuuma vee surve ventiilide abil, mis reguleerivad veevarustust hoones.

TÄHELEPANU

Külmumisohu tekkimisel laske vesi kogu süsteemist välja.

Tehnilised andmed

Töörõhk:	max. 1 MPa
Soovituslik töörõhk:	0,1 – 0,6 MPa
Kuuma vee temperatuur:	max. 75°C
Kuuma vee soovituslik temperatuur:	65°C
Termiline desinfektsioon:	70°C (3 min)

Toode on mõeldud ainult joogivee jaoks.

Nõuanded hoolduse kohta

Lubjaplekkide tekkimise vältimiseks on soovitatav toodet regulaarselt puhastada. Puhastamiseks tuleb kasutada seebi-lahust, seejärel loputada veega ning kuivatada kuiva pehme lapiga. Vedelseebi, šampooni, dušigeeli jäägid võivad samuti dekoratiivset viimistluskihti kahjustada. Nende sattumisel toote korpusele tuleb vastavat kohta puhta veega korralikult pesta. Toote viimistluskihi kahjustumise vältimiseks on abrasiivsete vahendite ja pastade kasutamine hoolduseks keelatud. Dekoratiivse viimistluskihi värvimuutuste vältimiseks ei tohi hoolduseks kasutada keemilisi vahendeid, mis sisaldavad agressiivseid keemilisi aineid: happeid, aluseid, atsetooni, ammooniumkloriidi ja teisi kloori sisaldavaid koostisaineid.

Tootja jätab endale õiguse teha toote ehituses, kujunduses ja komplekteerituses muudatusi ilma eelneva etteteatamiseta.



Remarques importantes concernant l'installation

Le produit doit être monté exclusivement par un ingénieur sanitaire spécialisé.

Porter des gants pendant l'installation pour éviter de se blesser.

Il convient d'appliquer les pratiques d'ingénierie généralement acceptées. (La conformité à la norme DIN EN 1717 est notamment recommandée).

Les alimentations en eau chaude et froide doivent être à pression égale avant l'installation des mitigeurs.



ATTENTION

Vidanger complètement le système en cas de risque de gel.

Caractéristiques techniques

Pression de fonctionnement:	max. 1 MPa
Pression de fonctionnement recommandée:	0,1 – 0,5 MPa
Température de l'eau chaude:	max. 75°C
Température de l'eau chaude recommandée:	65°C
Désinfection thermique:	70°C (3 min)

Ce produit est exclusivement conçu pour l'eau potable.



Recommandations d'entretien

Il est recommandé de nettoyer régulièrement le produit pour éviter les taches de calcaire.

Nettoyer avec une solution savonneuse en rinçant ensuite à l'eau et en éliminant l'humidité à l'aide d'un chiffon doux et sec.

Les restes de savon liquide, de shampooing et de gel douche peuvent également endommager le revêtement décoratif. S'ils pénètrent dans le boîtier de l'inverseur, le nettoyer soigneusement à l'eau claire.

Pour éviter d'endommager la surface du produit, il est interdit d'utiliser des solutions et des pâtes abrasives pour son nettoyage.

Pour éviter la décoloration du revêtement décoratif, il est interdit d'utiliser pour le nettoyage des détergents qui contiennent des substances chimiques agressives d'acides, d'alcalis, de chlorure d'ammonium et d'autres composants contenant du chlore.

Le producteur se réserve le droit, sans préavis, d'apporter des modifications à la conception et aux composants des appareils.



Svarbios pastabos įrengimui

Gaminio įrengimą turi vykdyti kvalifikuotas specialistas. Kad išvengtumėte traumų, rekomenduojame mūvėti pirštines. Įrengiant būtina taikyti bendrai priimtus inžinerinius sprendimus pagal galiojančias normas (rekomenduojamas atitikimas DIN EN 1717 normoms). Prieš įrengiant maišytuvą būtina vožtuvų, reguliuojančių vandens tiekimą į patalpą pagalba, išlyginti šalto ir karšto vandens slėgį.

DĖMESIO

Iškilus šalnų pavojui, pilnai nuleiskite vandenį iš sistemos.

Techniniai duomenys

Darbinis slėgis:	max. 1 MPa
Rekomenduojamas darbinis slėgis:	0,1 – 0,6 MPa
Karšto vandens temperatūra:	max. 75°C
Rekomenduojama karšto vandens temperatūra:	65°C
Terminė dezinfekcija:	70°C (3 min)

Gaminys skirtas tik geriamam vandeniui.



Priežiūros rekomendacijos

Kad išvengtumėte kalkių nuosėdų dėmių atsiradimo, rekomenduojame reguliariai valyti gaminį. Plauti reikia muilo tirpalu, nuskalauti švariu vandeniu ir nušluostyti sausa minkšta skepeta.

Skysto muilo, šampūno, dušo želės likučiai taip pat gali pažeisti dekoratyvinę dangą. Jei jie pateks ant gaminio korpuso, būtina tą vietą gerai nuplauti švariu vandeniu.

Kad išvengtumėte gaminio paviršiaus pažeidimų, draudžiama priežiūrai naudoti abrazyvines medžiagas ir pastas.

Kad išvengtumėte dekoratyvinės dangos spalvos pakitimo, draudžiama priežiūrai naudoti chemines priemones, kurių sudėtyje yra agresyvių cheminių medžiagų: rūgščių, šarmų, acetono, amonio chlorido ir kitų amonio turinčių komponentų.

Gamintojas pasilieka sau teisę daryti gaminio konstrukcijos, dizaino ir komplektacijos pakeitimus be išankstinio pranešimo.



Svarīgas piezīmes par uzstādīšanu

Izstrādājuma uzstādīšana ir jāveic kvalificētam speciālistam. Lai izvairītos no traumām, ieteicams lietot cimdus. Uzstādot jāizmanto vispārpieņemtie inženiertehniskie risinājumi saskaņā ar spēkā esošajām normām (ieteicama atbilstība DIN EN 1717 normām). Pirms jaucējkrāna uzstādīšanas jāizlīdzina aukstā un karstā ūdens spiediens, izmantojot ventīļus, kuri regulē ūdens padevi telpā.



UZMANĪBU

Pastāvot salnu iespējām, izlejiet pilnībā ūdeni no sistēmas.

Tehniskie dati

Darba spiediens:	max. 1 MPa
Leteicamais darba spiediens:	0,1 – 0,6 MPa
Karstā ūdens temperatūra:	max. 75°C
Leteicamā karstā ūdens temperatūra:	65°C
Termiskā dezinfekcija:	70°C (3 min)

Izstrādājums paredzēts tikai dzeramajam ūdenim.



Leteikumi apkopei

Lai izvairītos no kaļķakmens nogulšņu plankumu rašanās, izstrādājumu ieteicams regulāri tīrīt. Mazgāšana jāveic ar ziepju šķīdumu, pēc tam jānoskalo ar ūdeni un mitrums jānoņem ar sausu mīkstu drānu.

Šķidro ziepju, šampūna, dušas želejas atliekas arī var radīt dekoratīvā pārklājuma bojājumu. Tiem nonākot uz izstrādājuma korpusa, šī vieta rūpīgi jānomazgā ar tīru ūdeni.

Lai izvairītos no izstrādājuma virsmas sabojāšanas, apkopei aizliegts izmantot abrazīvus līdzekļus un pastas.

Lai izvairītos no dekoratīvā pārklājuma krāsas izmaiņas, apkopei aizliegts izmantot ķīmiskus līdzekļus, kuri satur agresīvas ķīmiskas vielas: skābes, sārmus, acetonu, amonija hlorīdu un citus hloru saturošus komponentus.

Ražotājs patur tiesības bez iepriekšēja brīdinājuma veikt izmaiņas izstrādājuma konstrukcijā, dizainā un komplektācijā.



Важные замечания по установке

Установка изделия должна осуществляться квалифицированным специалистом.

Во избежание травм рекомендуется использование перчаток.

При установке следует применять общепринятые инженерные решения в соответствии с действующими нормами (рекомендуется соответствие нормам DIN EN 1717).

Перед установкой смесителя необходимо выровнять давление холодной и горячей воды при помощи вентилей, регулирующих подачу воды в помещении.



ВНИМАНИЕ

При возникновении опасности заморозков, полностью слейте воду из системы.

Технические данные

Рабочее давление:	max. 1 МПа
Рекомендуемое рабочее давление:	0,1 – 0,6 МПа
Температура горячей воды:	max. 75°C
Рекомендуемая температура горячей воды:	65°C
Термическая дезинфекция:	70°C (3 min)

Изделие предназначено только для питьевой воды.



Рекомендации по уходу

Во избежание появления пятен известковых отложений, изделие рекомендуется подвергать регулярной чистке. Мытье следует производить мыльным раствором, с последующей промывкой водой и удалением влаги сухой мягкой тряпкой.

Остатки жидкого мыла, шампуня, геля для душа также могут вызывать повреждение декоративного покрытия. В случае их попадания на корпус изделия, необходимо тщательно промыть место попадания чистой водой. Во избежание повреждения поверхности изделия, запрещается применять для ухода абразивные средства и пасты.

Во избежание изменения цвета декоративного покрытия, запрещается применять для ухода химические средства, содержащие агрессивные химические вещества: кислоты, щелочи, ацетон, хлорид аммония и другие хлорсодержащие компоненты.

Производитель оставляет за собой право на внесение изменений в конструкцию, дизайн и комплектацию изделия без предварительного уведомления.



Важливі зауваження по установці

Установка виробу має виконуватись кваліфікованим спеціалістом.

Для уникнення травм рекомендується використання рукавиць.

При установці слід застосовувати загальноприйняті інженерні рішення у відповідності з діючими нормами (рекомендовано відповідність нормам DIN EN 1717)

Перед установкою змішувача необхідно вирівняти тиск холодної та гарячої води за допомогою вентелів, регулюючих подачу води до приміщень.



УВАГА

При виникненні небезпеки заморозків, повністю злийте воду із системи.

Технічні дані:

Робочий тиск:	max. 1 МПа
Рекомендований робочий тиск:	0,1 – 0,6 МПа
Температура гарячої води:	max. 75°C
Рекомендована температура гарячої води:	65°C
Термічна дезінфекція:	70°C (3 min)

Виріб призначений тільки для питної води.



Рекомендації по догляду

Для запобігання виникнення плям, вапняних відкладень, виріб рекомендується регулярно чистити мильним розчином, з послідуєчим промиванням чистою водою та видаленням вологи сухою м'якою тканиною.

Залишки рідкого мила, шампуню, гелю для душу також можуть призвести до пошкодження декоративного покриття. У випадку їх попадання на корпус виробу, необхідно ретельно промити чистою водою.

Для запобігання пошкодження поверхні виробу, забороняється застосовувати для догляду абразивні миючі засоби.

Для запобігання зміни кольору декоративного покриття, забороняється застосовувати для догляду хімічні засоби, що містять агресивні хімічні речовини: кислоти, лужні, ацетон, хлорид амонію і інші хлорвмісні компоненти.

Виробник залишає за собою право на внесення змін в конструкцію, дизайн, комплектацію виробу без попереднього узгодження.

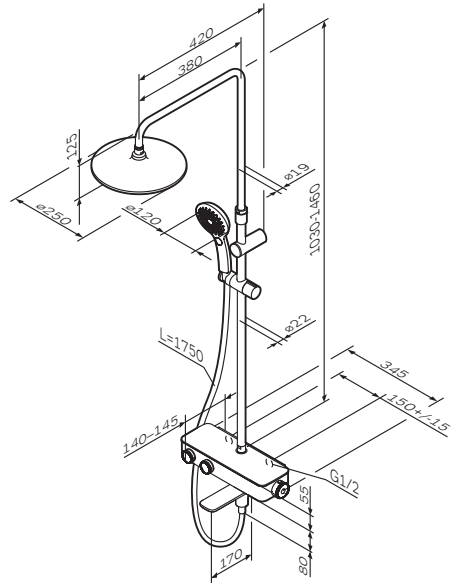
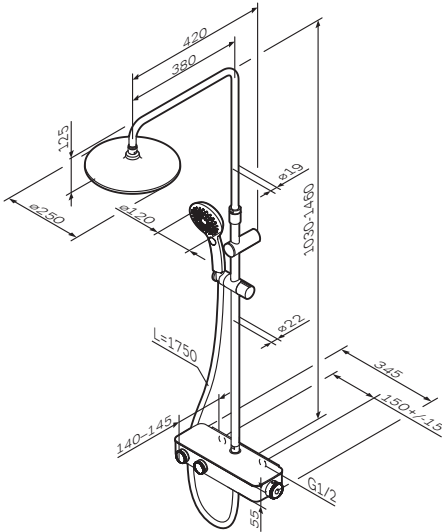

Inspire V2.0 F0750A400

- CHI** ShowerSpot
- DEU** Regenbrause-Set
- ENG** ShowerSpot
- EST** Dušisüsteem
- FRA** Système de douche
- LTU** Dušo sistema
- LVA** Dušas sistēma
- RUS** Душевая система
- UKR** Душова система

Inspire V2.0 F0750A500

- CHI** ShowerSpot
- DEU** Regenbrause-Set
- ENG** ShowerSpot
- EST** Dušisüsteem
- FRA** Système de douche
- LTU** Dušo sistema
- LVA** Dušas sistēma
- RUS** Душевая система
- UKR** Душова система

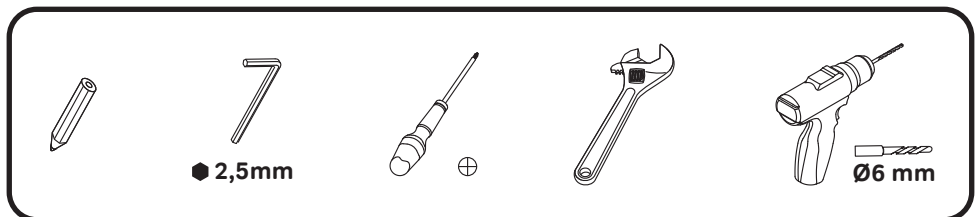

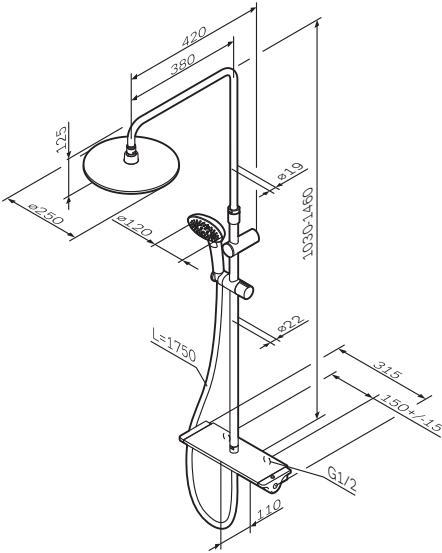

Spirit V2.0 F0770A400

CHI ShowerSpot
DEU Regenbrause-Set
ENG ShowerSpot
EST Dušisüsteem
FRA Système de douche
LTU Dušo sistema
LVA Dušas sistēma
RUS Душевая система
UKR Душова система

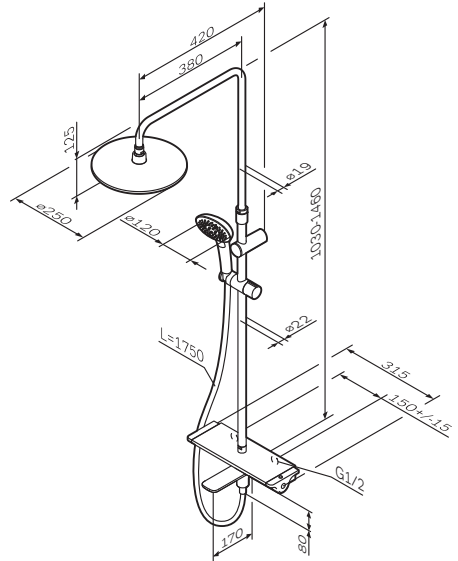

Spirit V2.0 F0770A500

CHI ShowerSpot
DEU Regenbrause-Set
ENG ShowerSpot
EST Dušisüsteem
FRA Système de douche
LTU Dušo sistema
LVA Dušas sistēma
RUS Душевая система
UKR Душова система

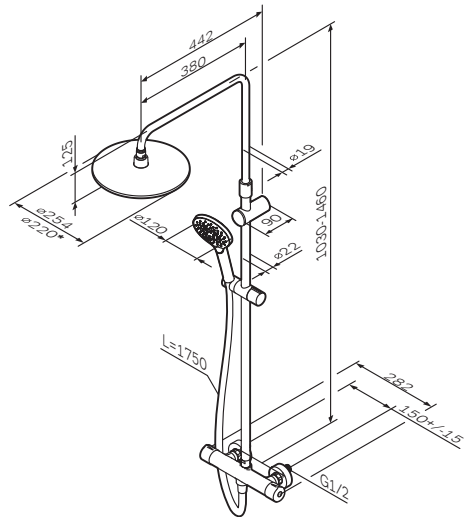
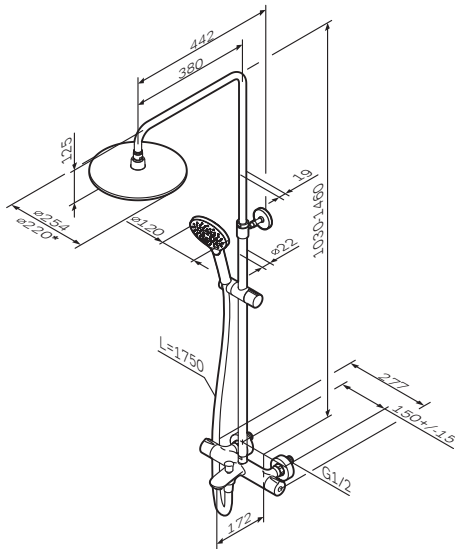

Like
F0780564
F0780522*

- CHI** ShowerSpot
- DEU** Regenbrause-Set
- ENG** ShowerSpot
- EST** Dušisüsteem
- FRA** Système de douche
- LTU** Dušo sistema
- LVA** Dušas sistēma
- RUS** Душевая система
- UKR** Душова система

Like
F0780464
F0780422*

- CHI** ShowerSpot
- DEU** Regenbrause-Set
- ENG** ShowerSpot
- EST** Dušisüsteem
- FRA** Système de douche
- LTU** Dušo sistema
- LVA** Dušas sistēma
- RUS** Душевая система
- UKR** Душова система

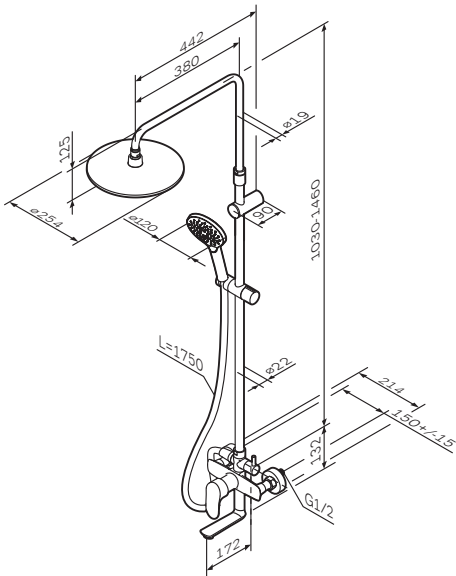

Like F0780964

CHI ShowerSpot
 DEU Regenbrause-Set
 ENG ShowerSpot
 EST Dušisüsteem
 FRA Système de douche
 LTU Dušo sistema
 LVA Dušas sistēma
 RUS Душевая система
 UKR Душова система

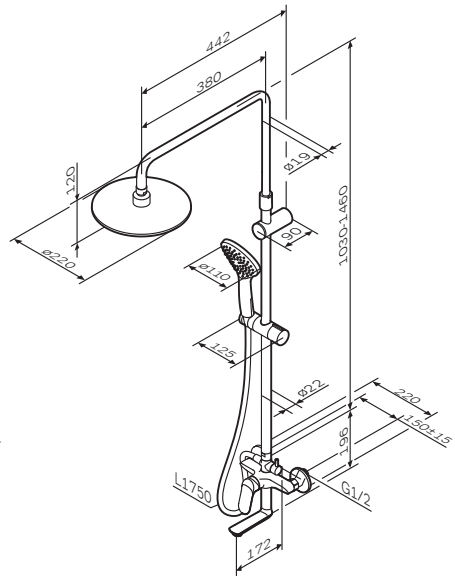

Sunny F0785C900/22

CHI ShowerSpot
 DEU Regenbrause-Set
 ENG ShowerSpot
 EST Dušisüsteem
 FRA Système de douche
 LTU Dušo sistema
 LVA Dušas sistēma
 RUS Душевая система
 UKR Душова система

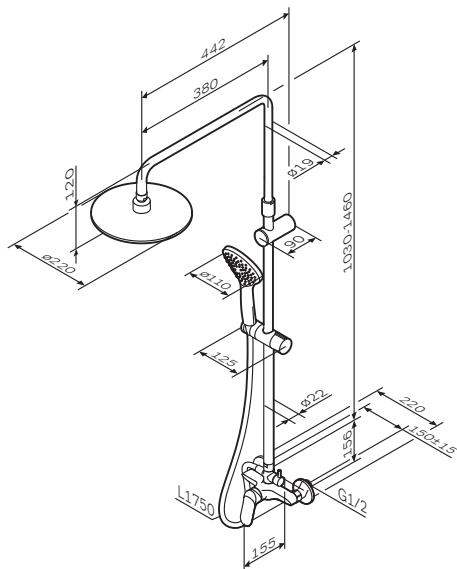

Sunny
F0785C800/22

- CHI** ShowerSpot
- DEU** Regenbrause-Set
- ENG** ShowerSpot
- EST** Dušisüsteem
- FRA** Système de douche
- LTU** Dušo sistema
- LVA** Dušas sistēma
- RUS** Душевая система
- UKR** Душова система

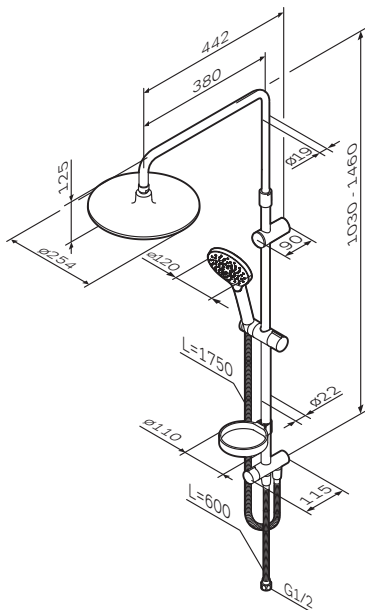

Like
F0780064

- CHI** ShowerSpot
- DEU** Regenbrause-Set
- ENG** ShowerSpot
- EST** Dušisüsteem
- FRA** Système de douche
- LTU** Dušo sistema
- LVA** Dušas sistēma
- RUS** Душевая система
- UKR** Душова система

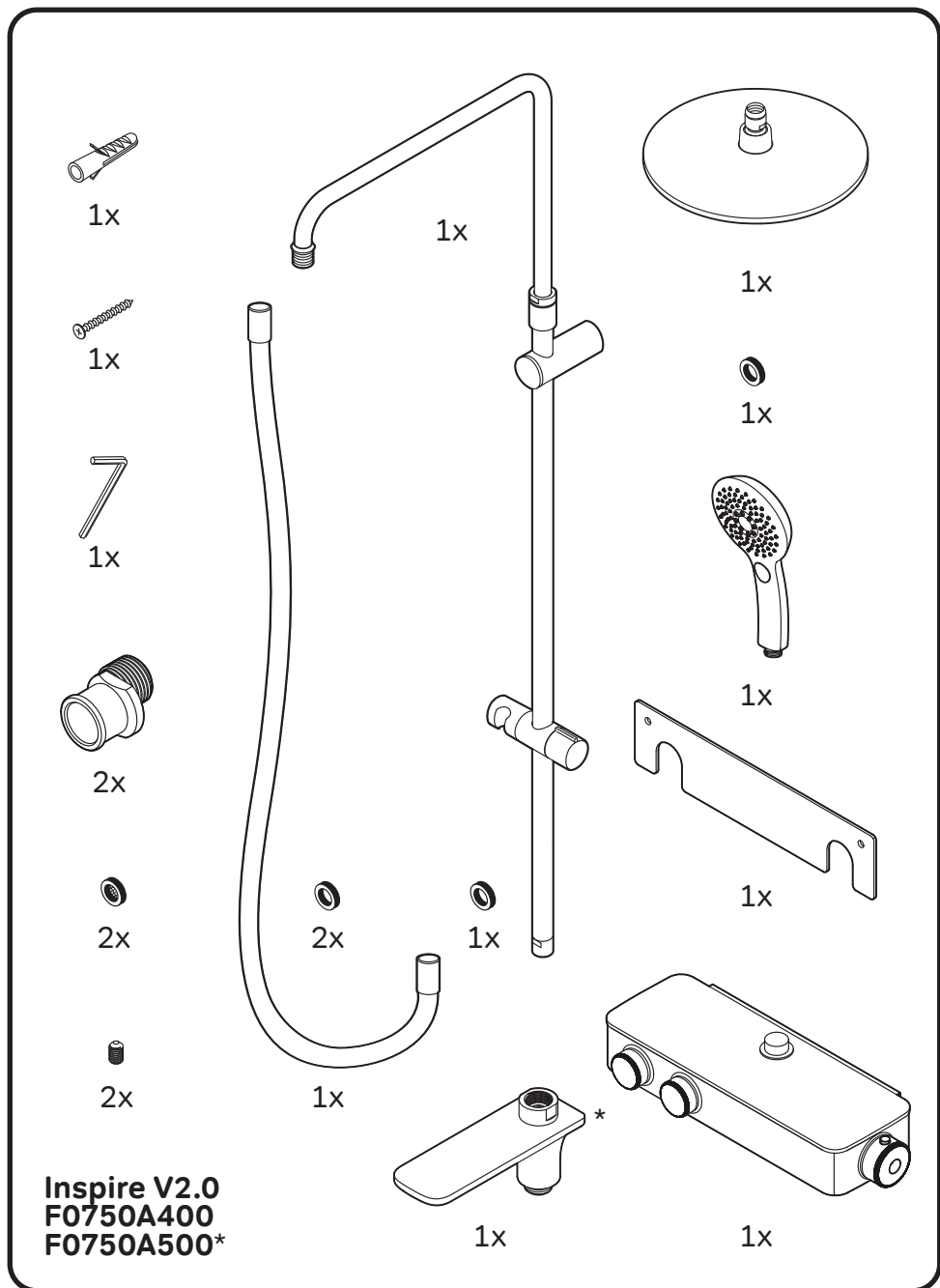



1x



1x



1x



1x



1x

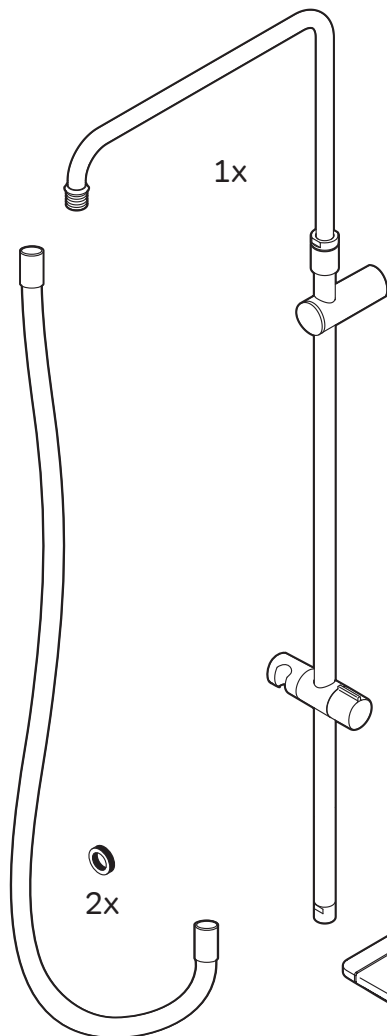

1x

2x

1x

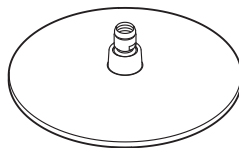

1x

1x



1x



2x

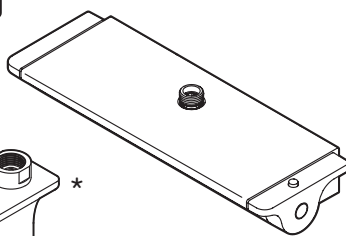

1x

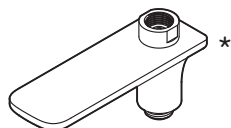

1x

Spirit V2.0
F0770A400
F0770A500*



1x



1x



1x



1x



1x



2x



2x

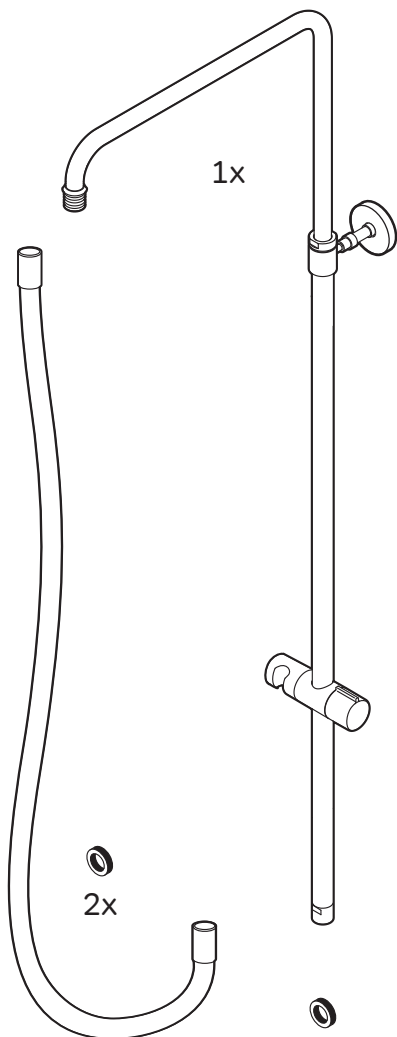

1x

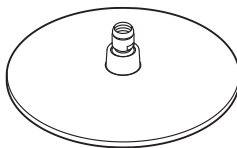

1x



1x



1x



2x

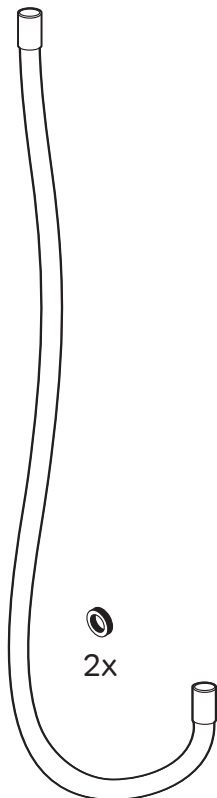

2x

1x



1x



1x

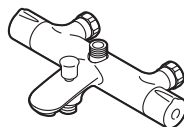

1x

Like
F0780564/22



1x



1x



1x



2x



2x



2x

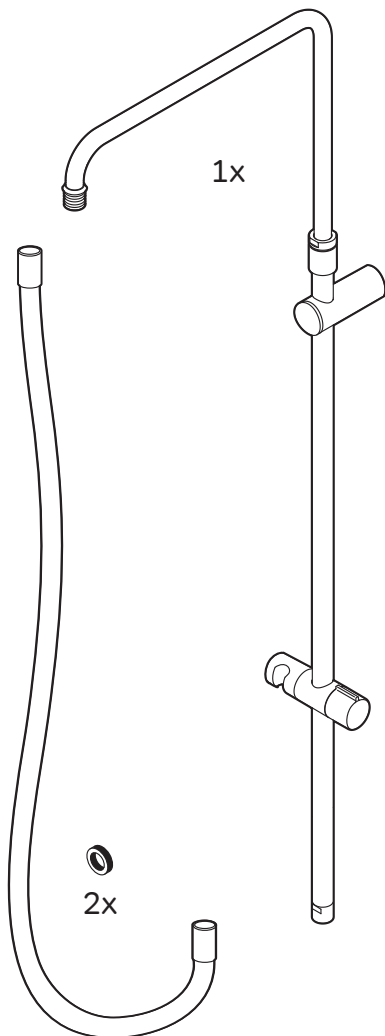

1x

2x

1x

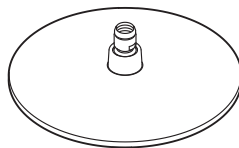

1x



1x



1x

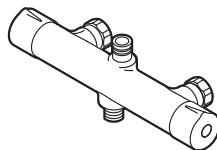

1x

Like
F0780464/22



1x



1x



2x



2x



2x

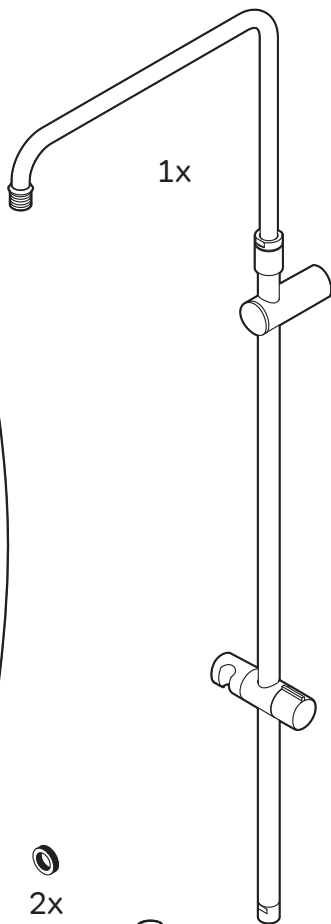

1x

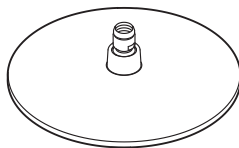

1x



1x



1x

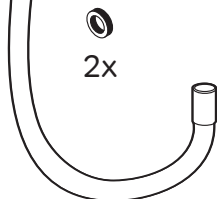

2x

1x



1x



2x

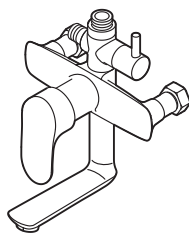

1x

Like
F0780964



1x



1x



2x



2x



2x

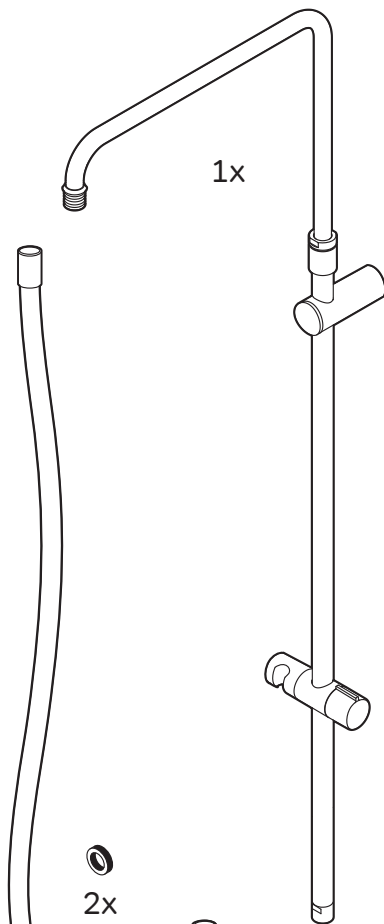

1x

2x

1x

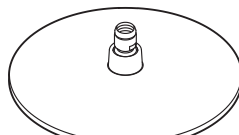

1x



1x



1x

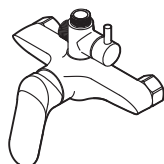

1x

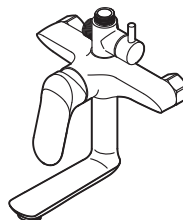

1x

Sunny
F0785C900/22
F0785C800/22*

1x

2x

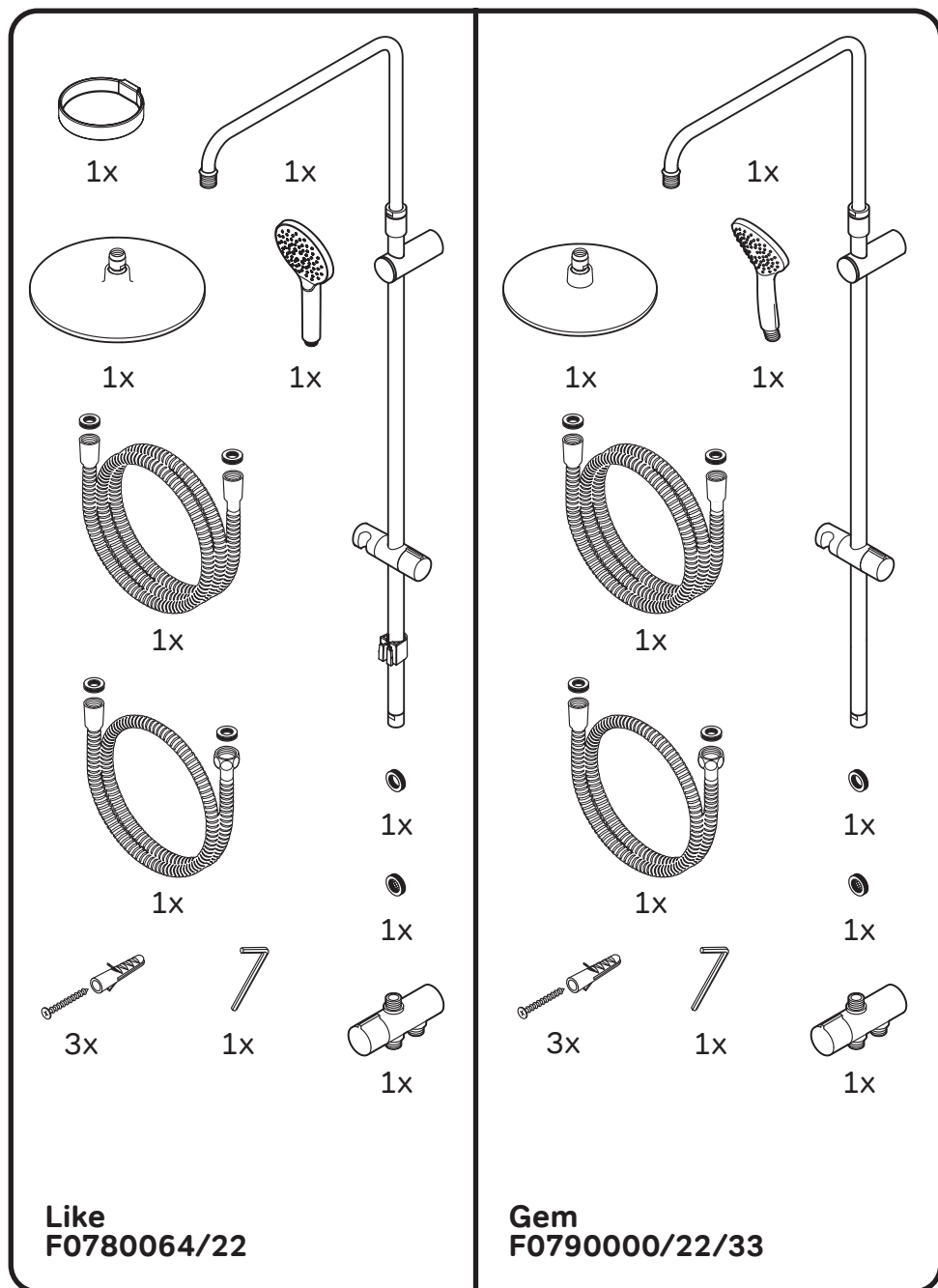

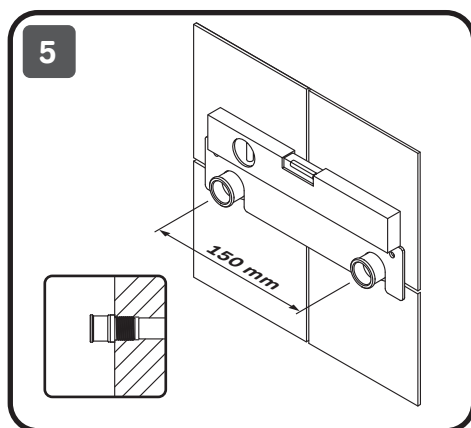
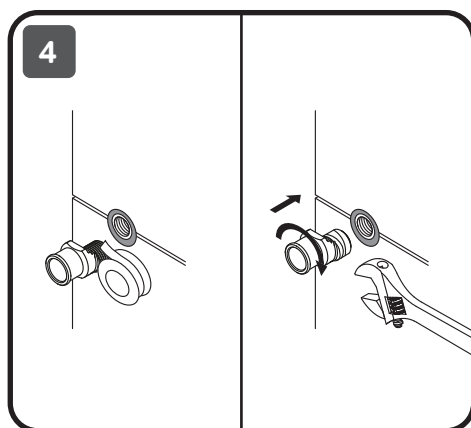
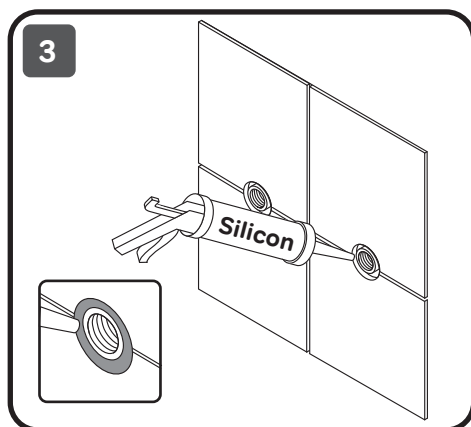
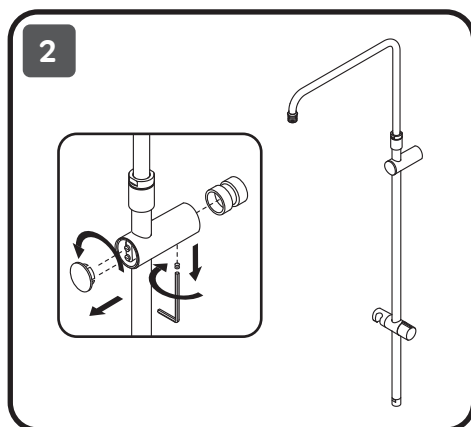
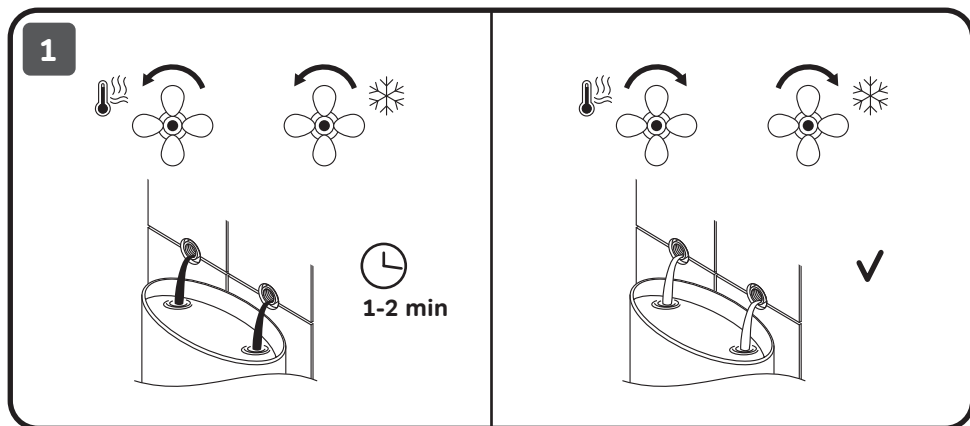

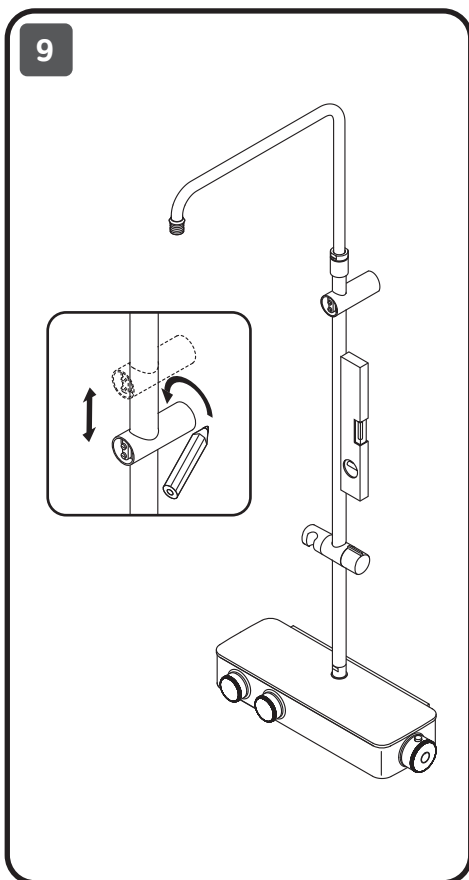
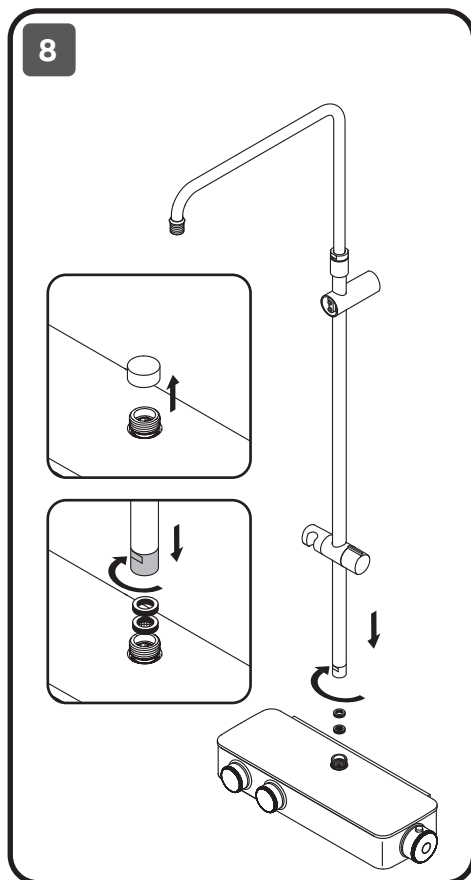
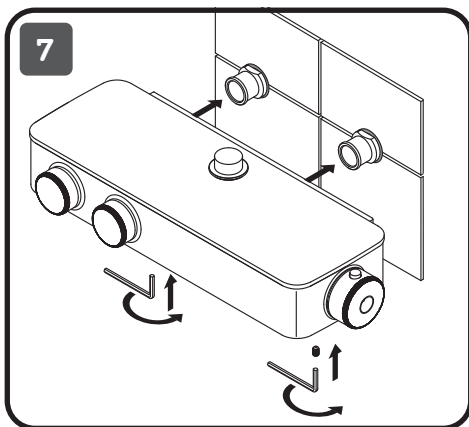
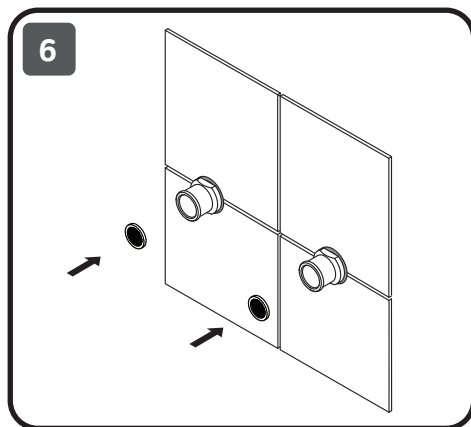

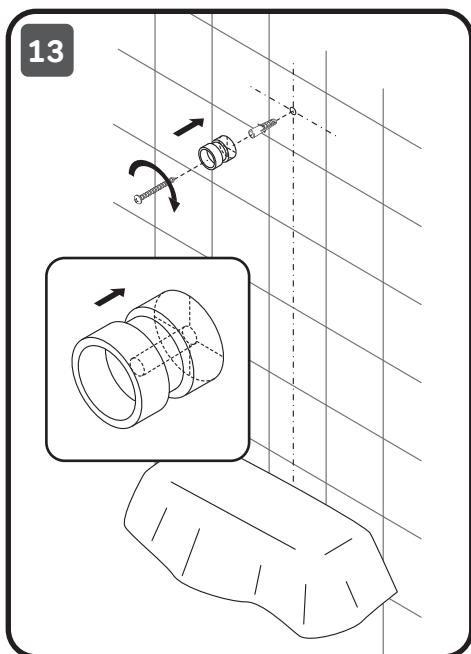
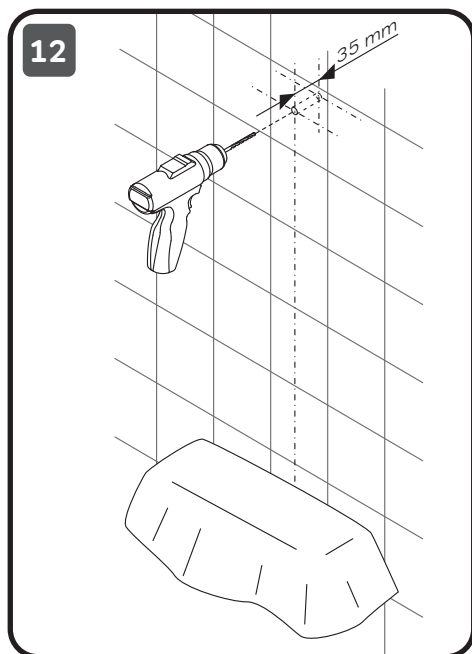
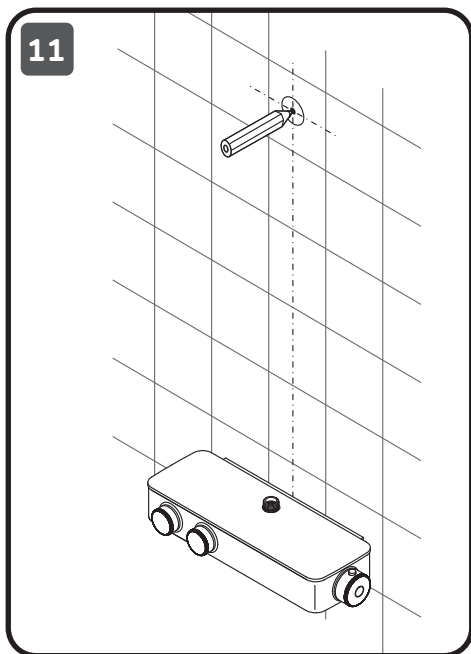
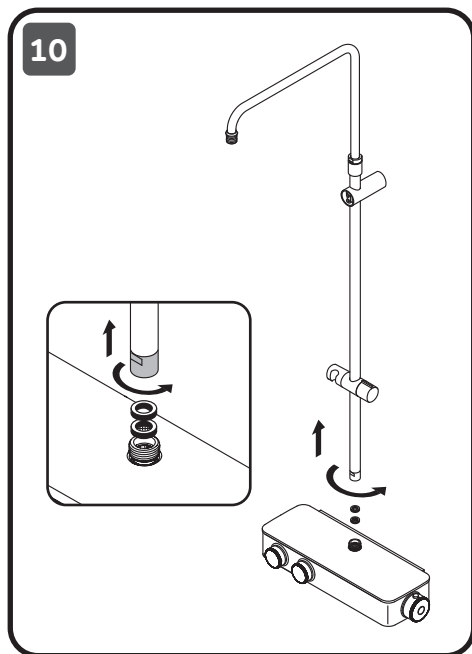



14

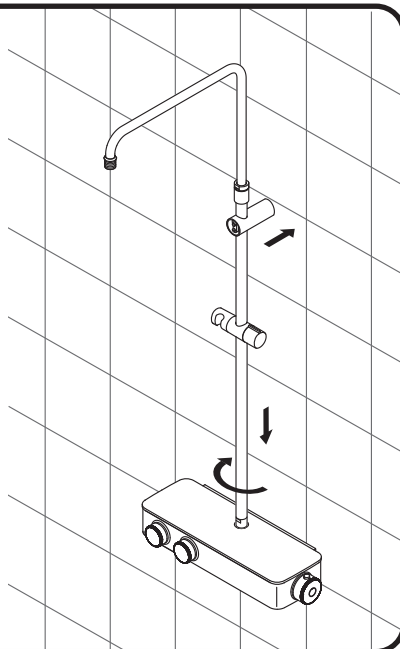
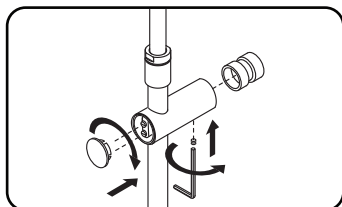
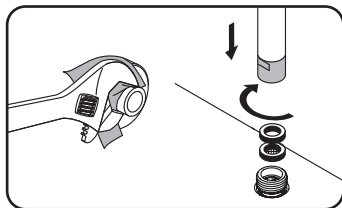

15

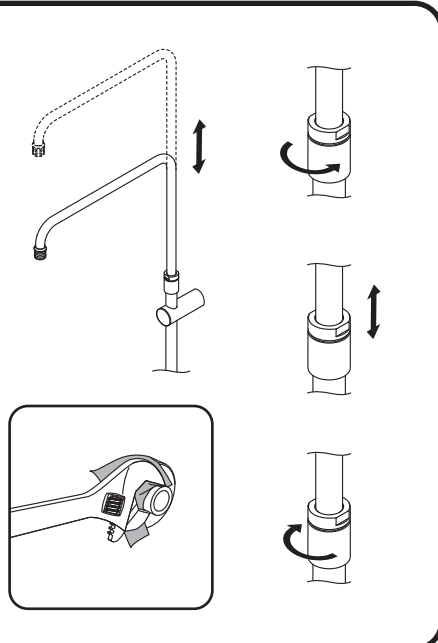
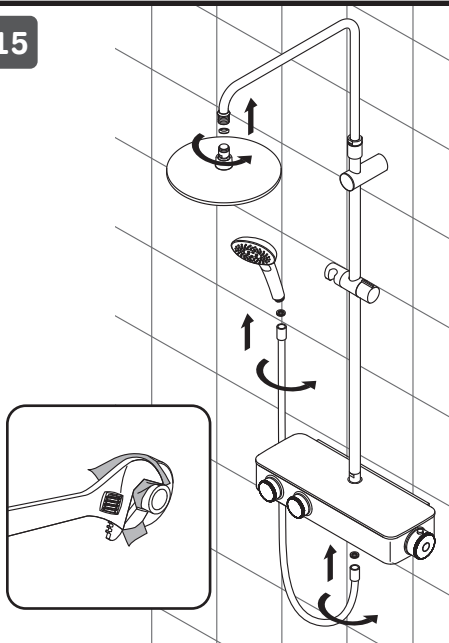

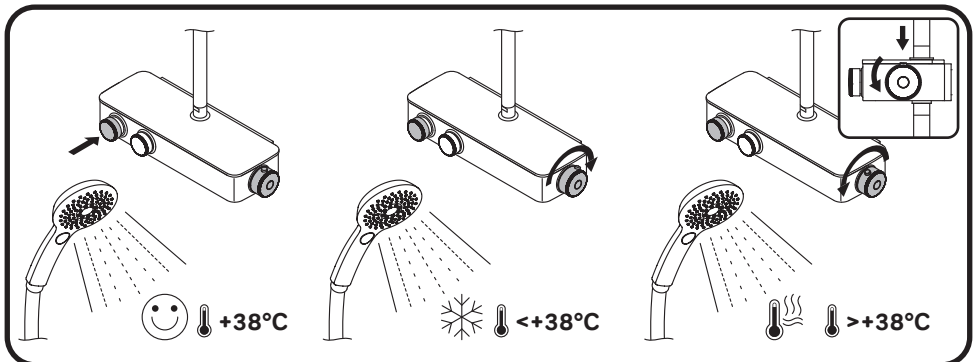
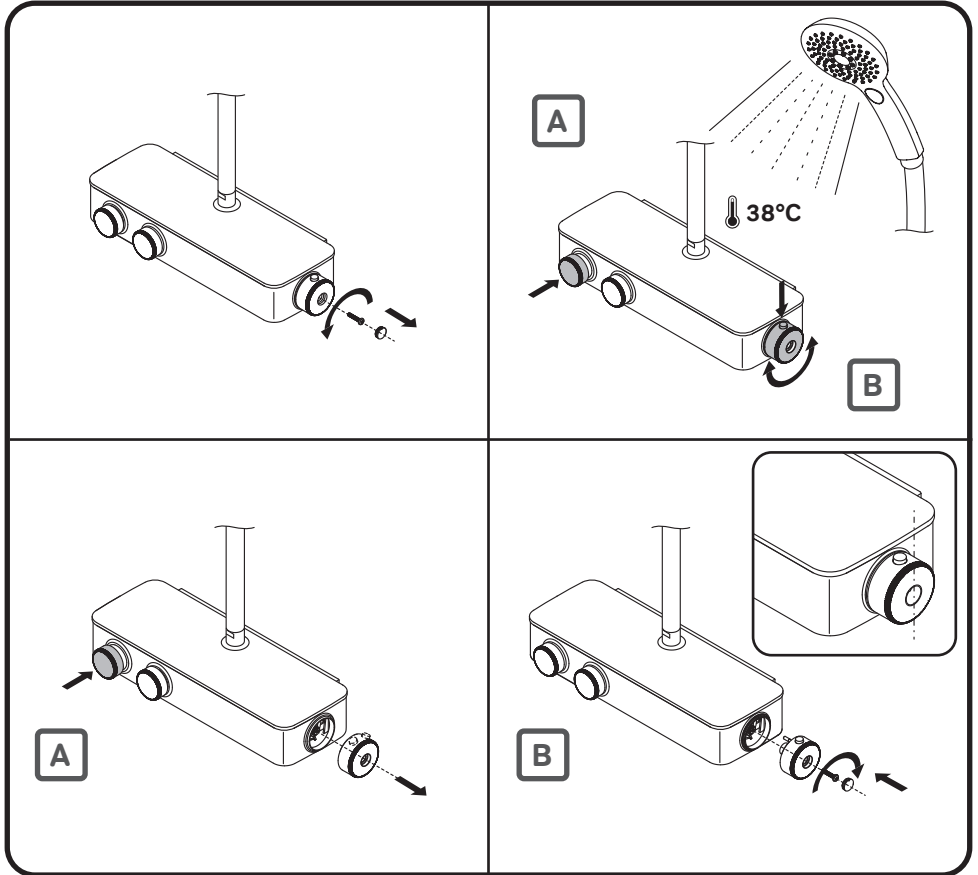

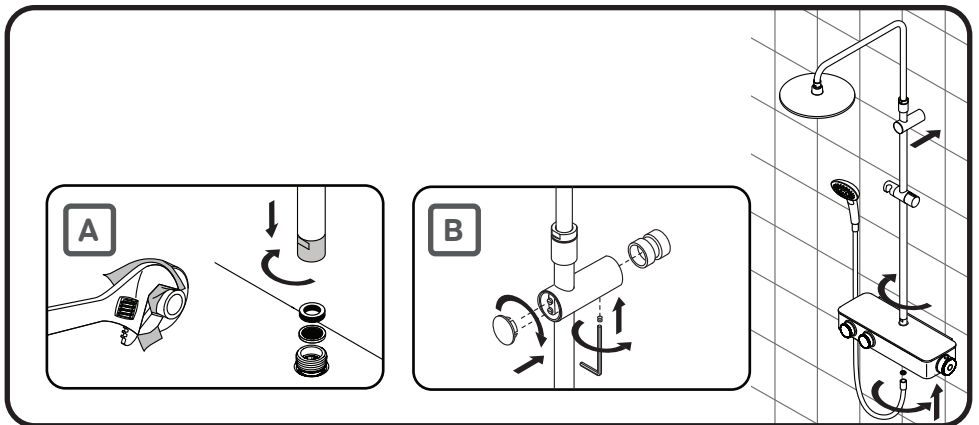
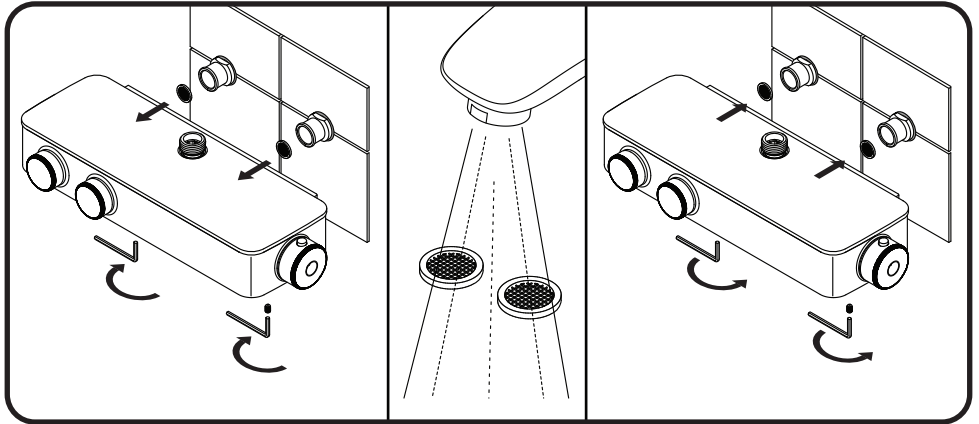
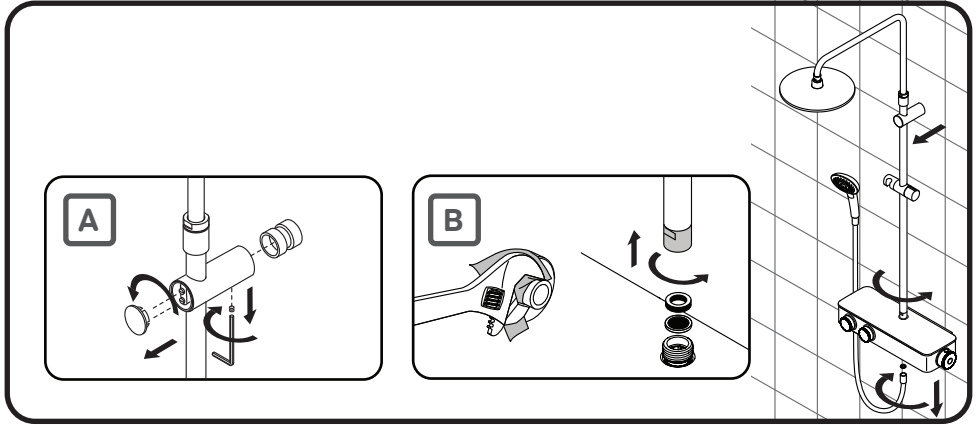

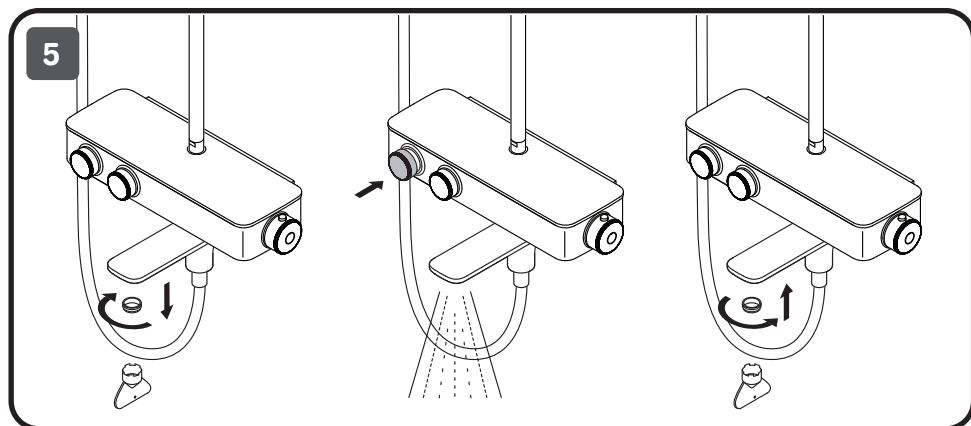
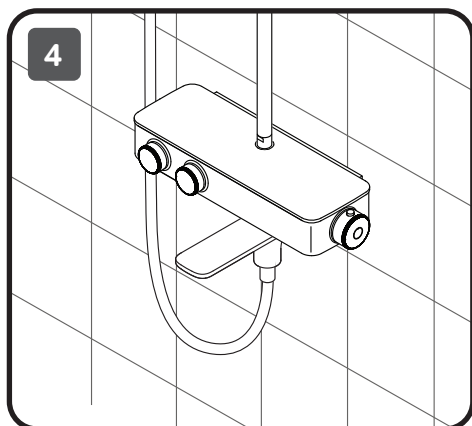
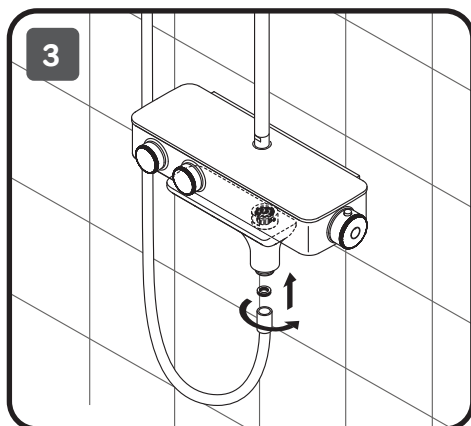
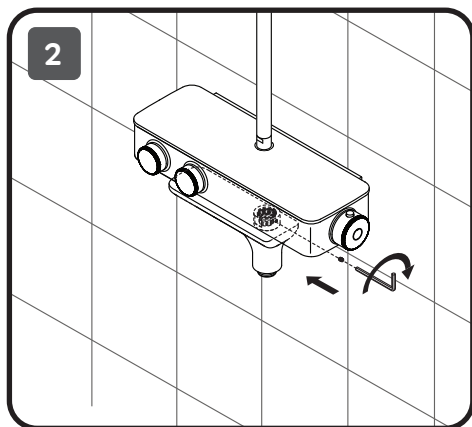
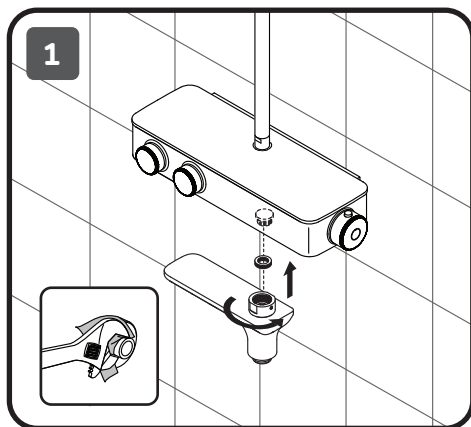



Inspire V2.0 F0750A400 / Inspire V2.0 F0750A500

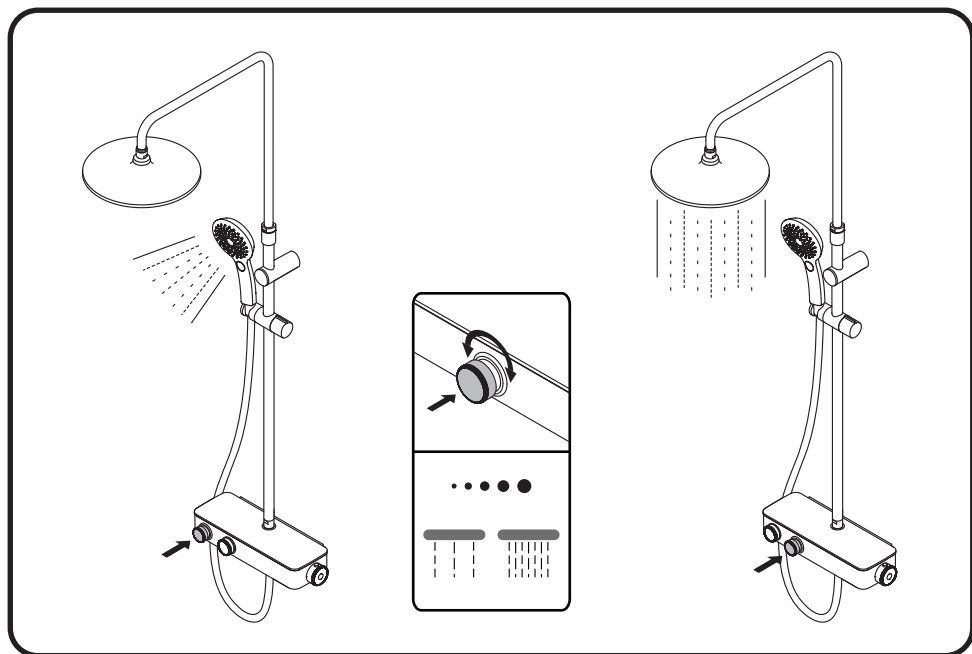

Inspire V2.0 F0750A500

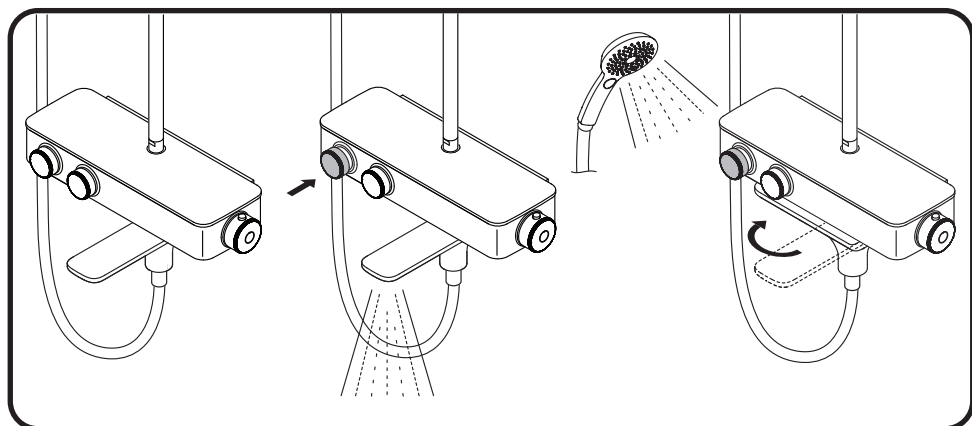

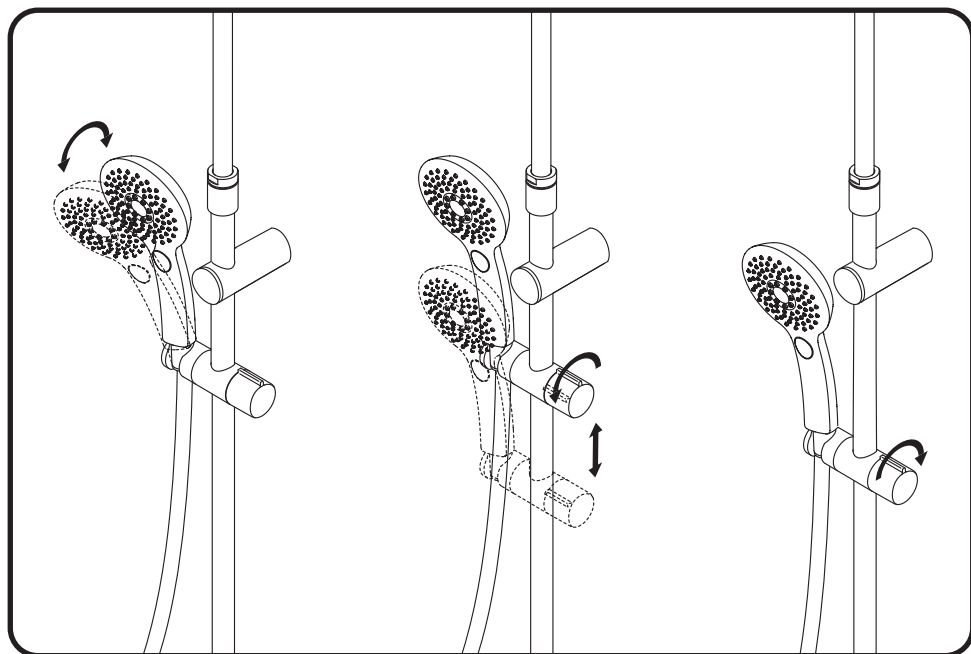

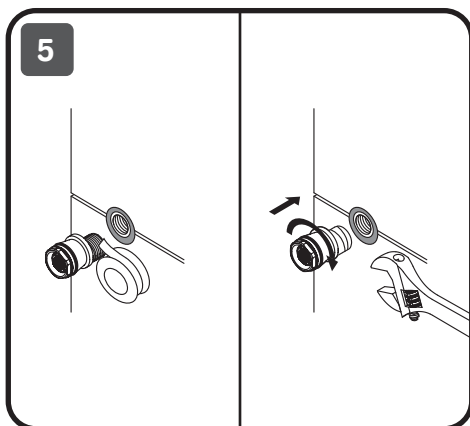
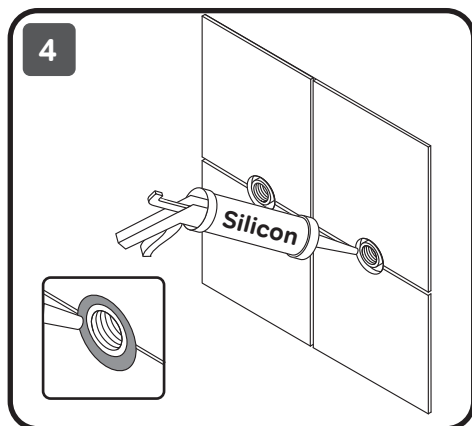
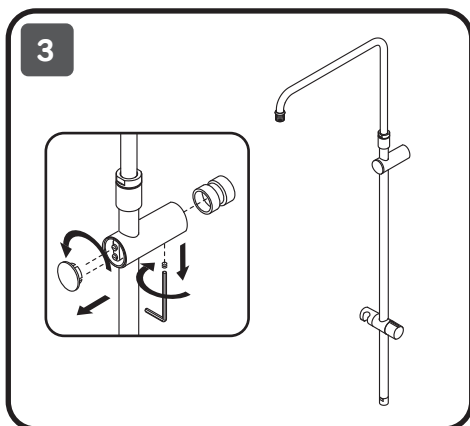
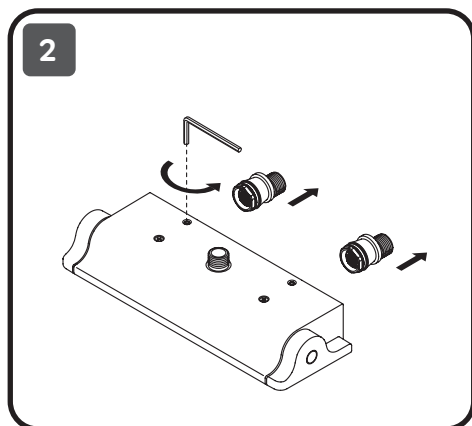
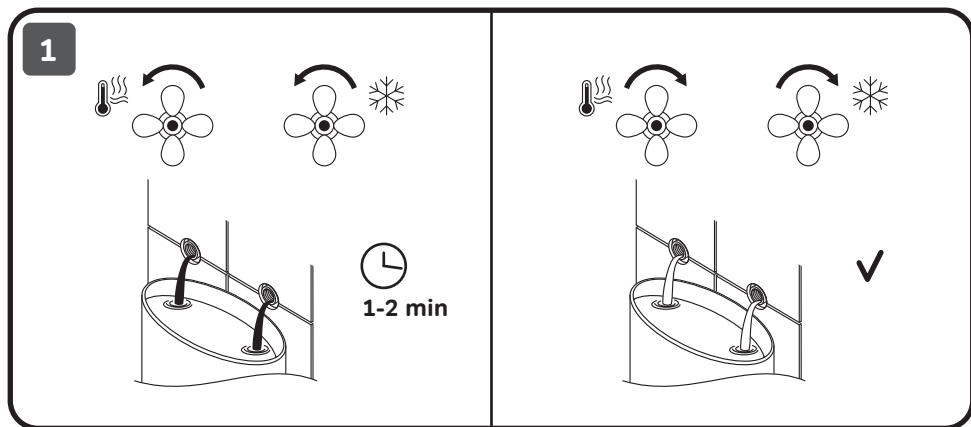

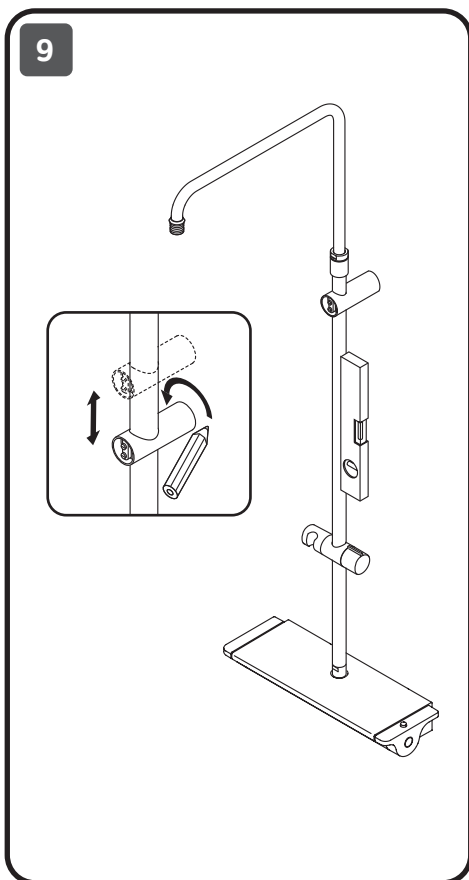
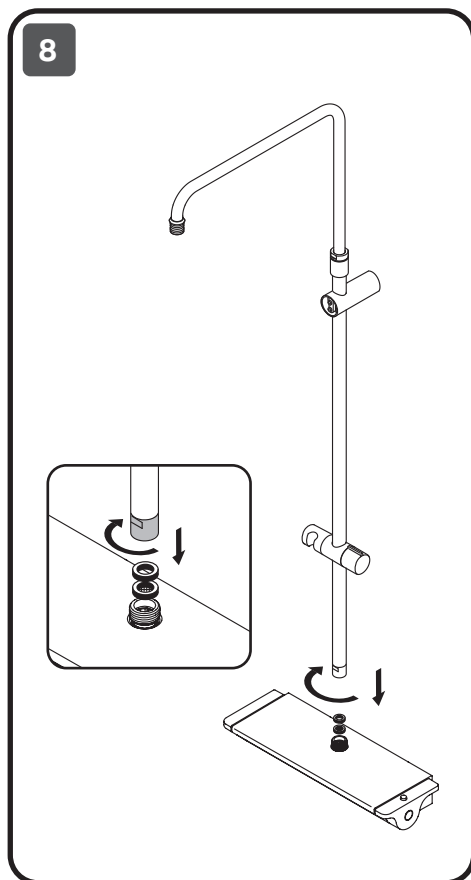
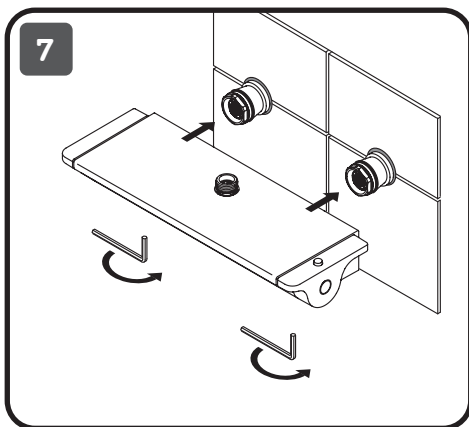
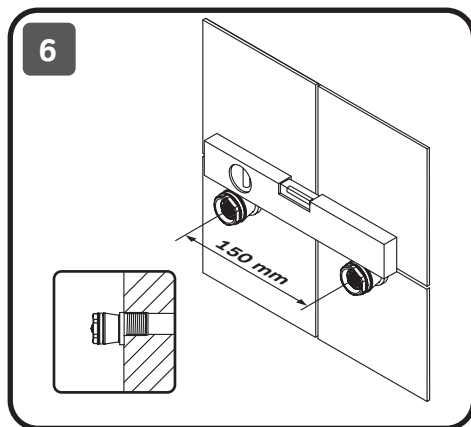

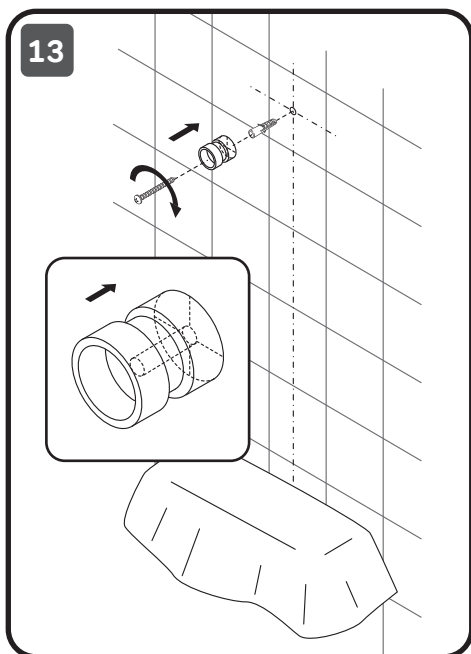
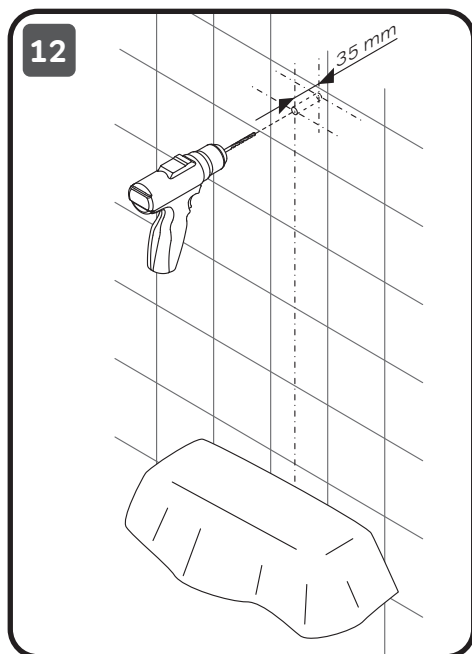
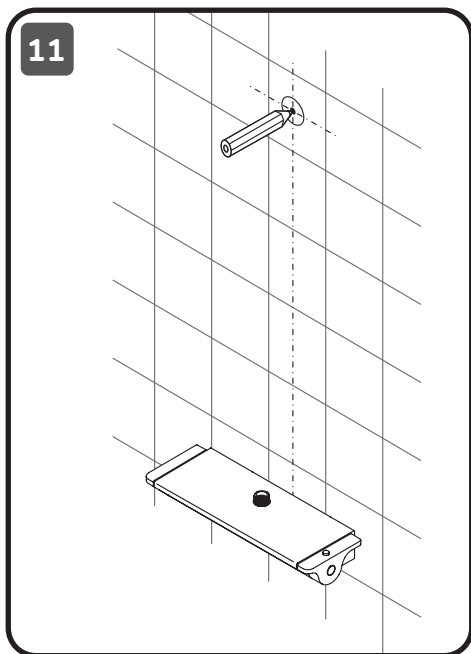
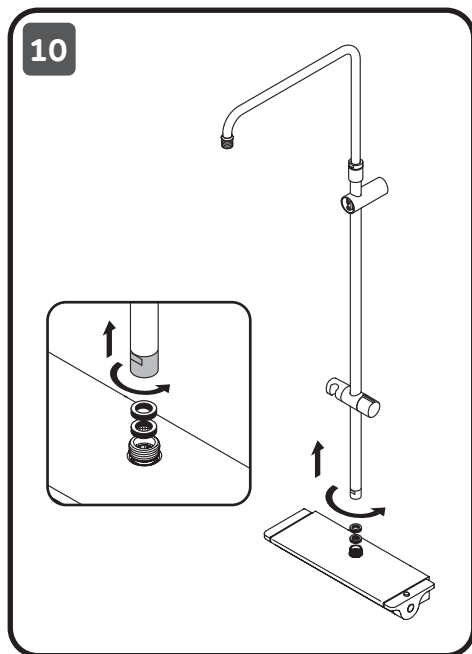



14

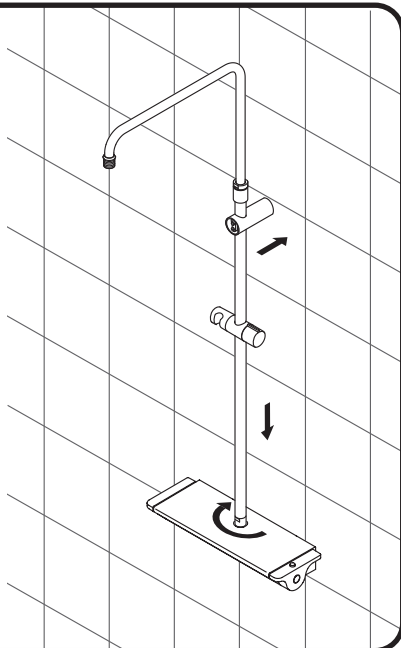
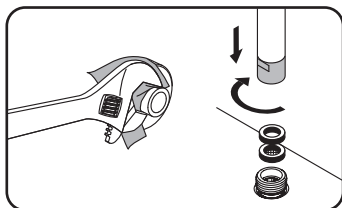
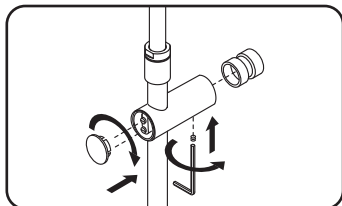

15

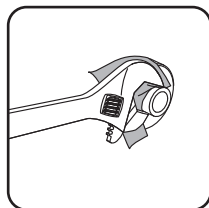
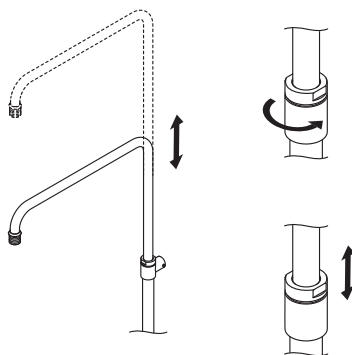
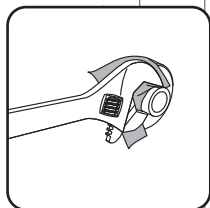
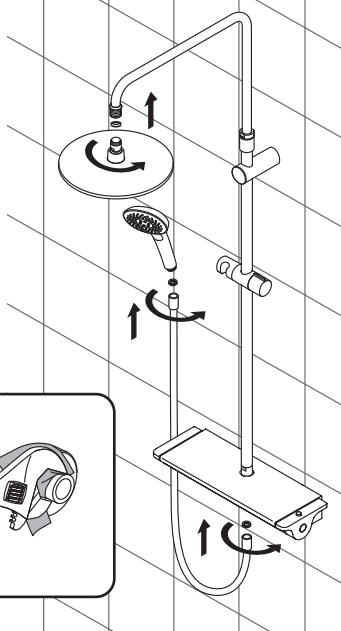

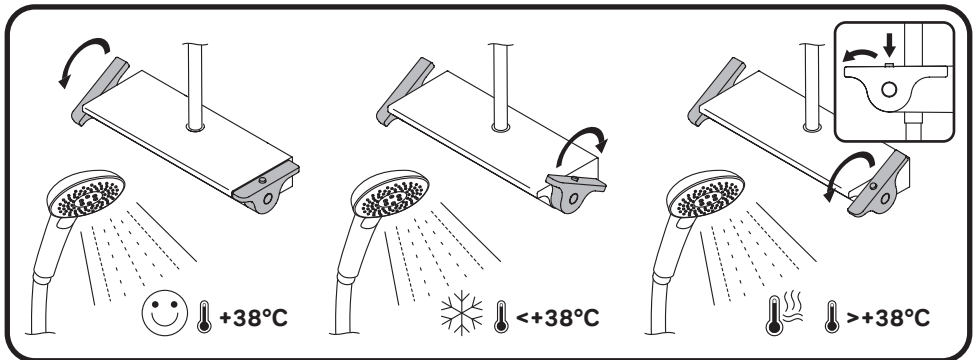
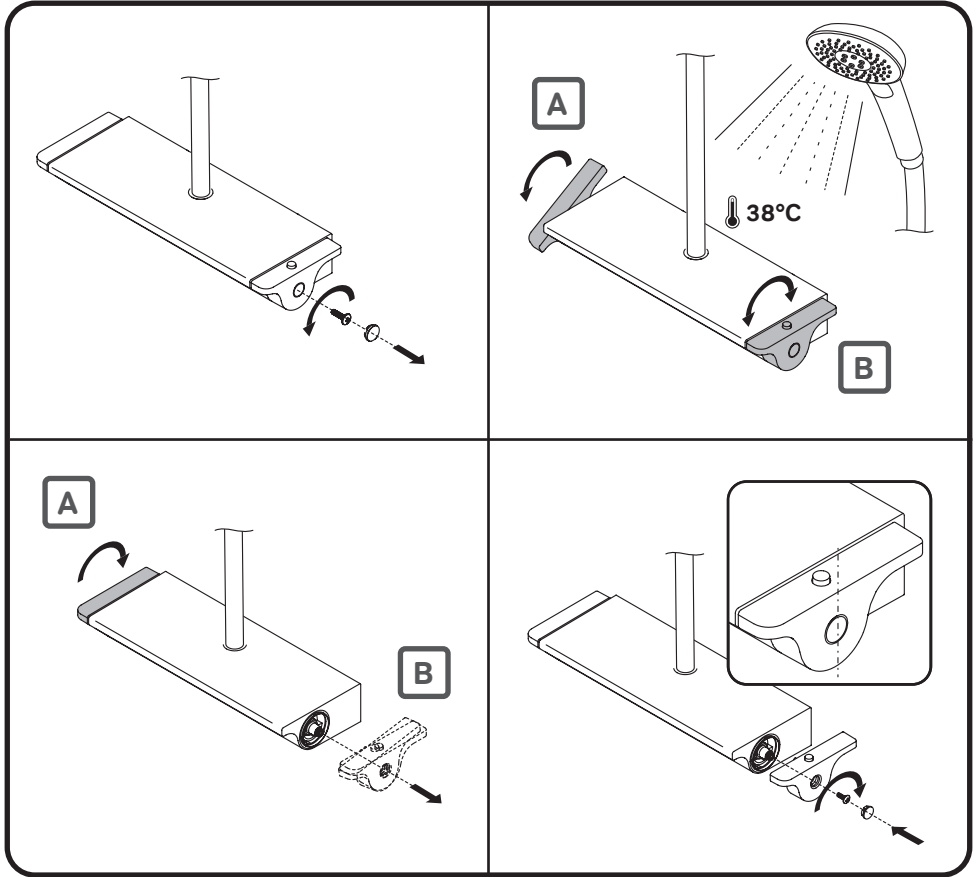

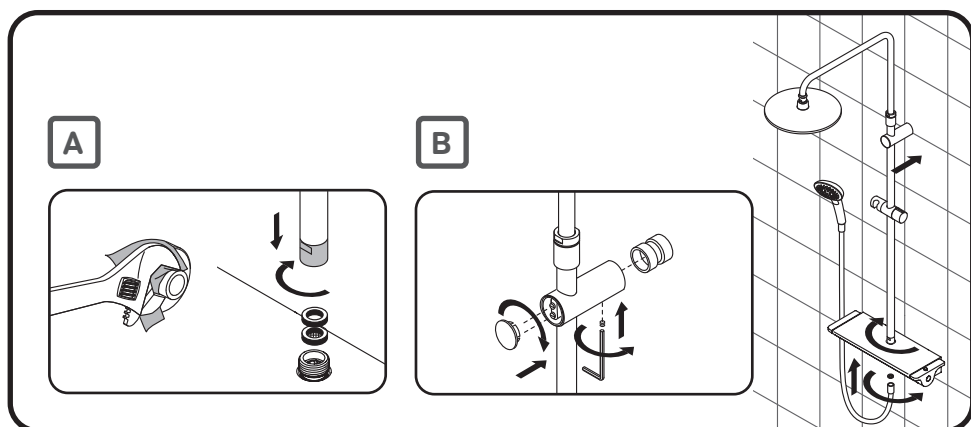
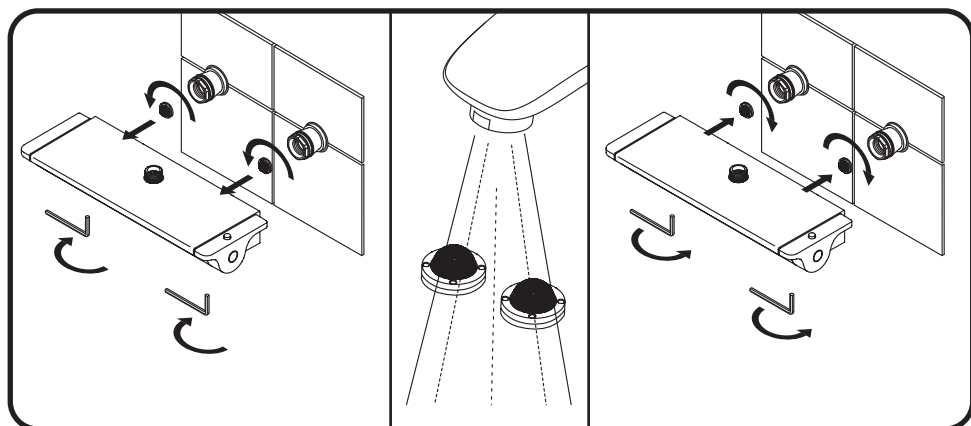
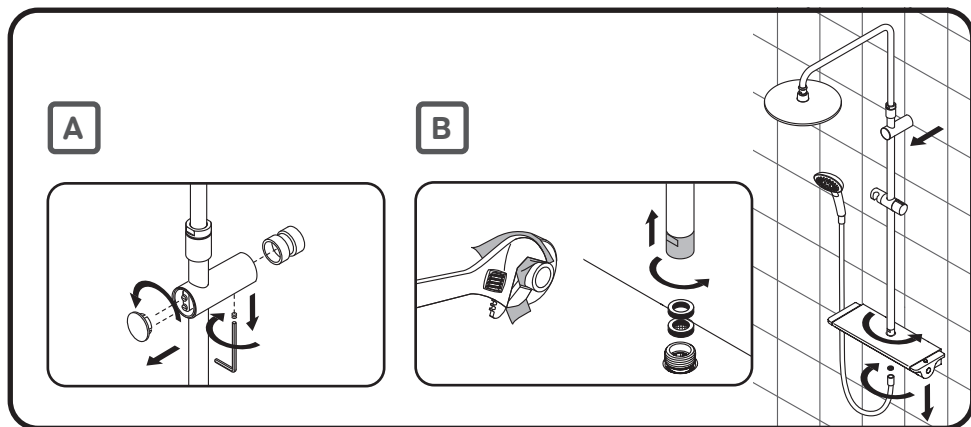



Spirit V2.0 F0770A400 / Spirit V2.0 F0770A500

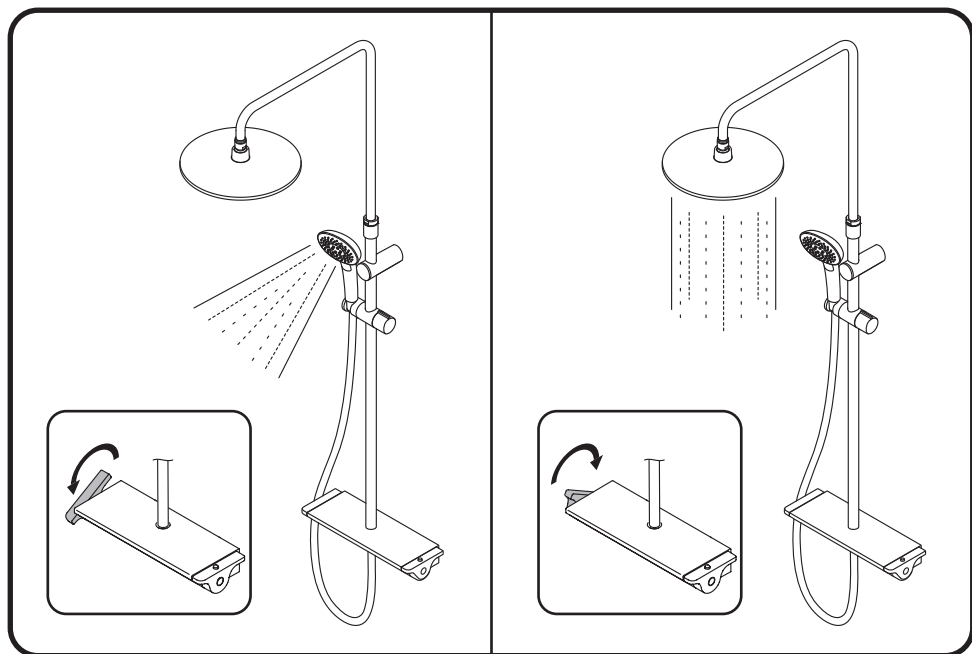

Spirit V2.0 F0770A500

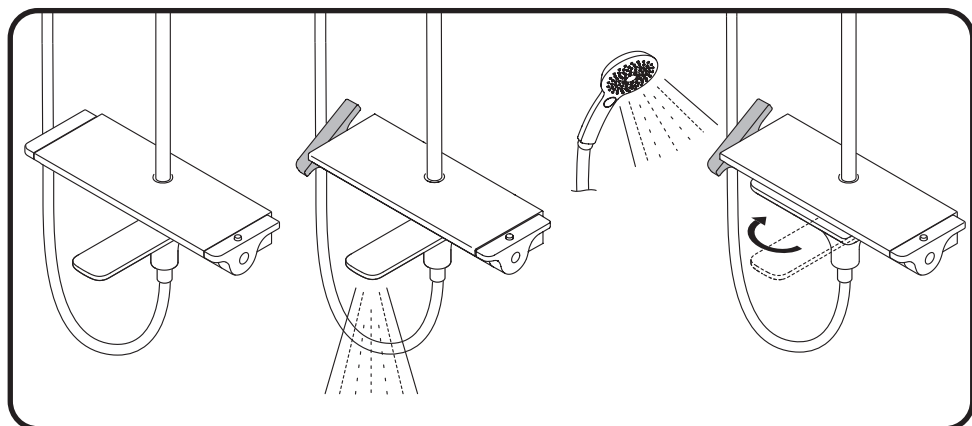

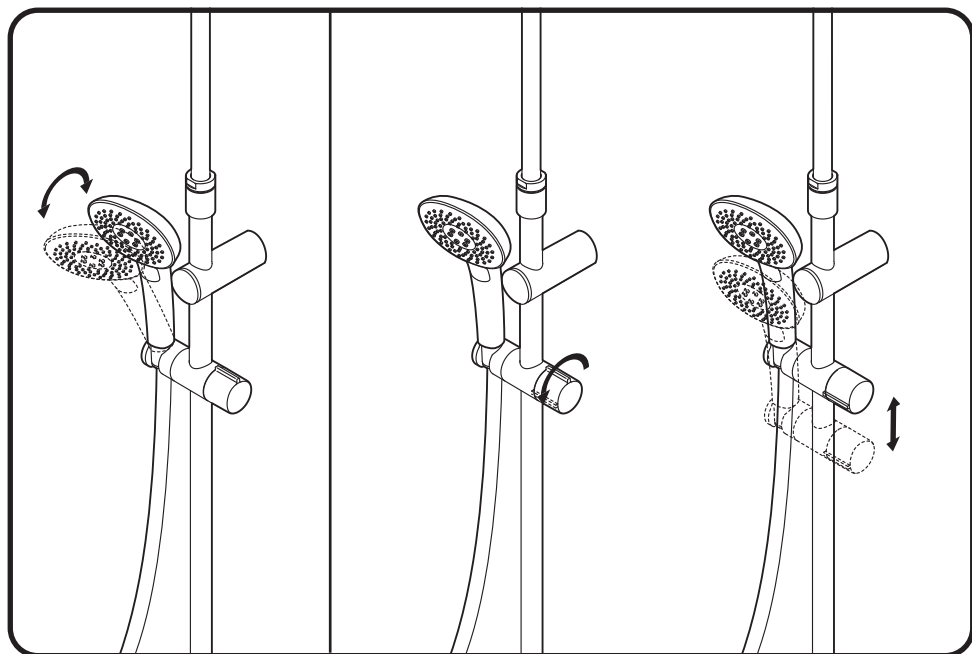

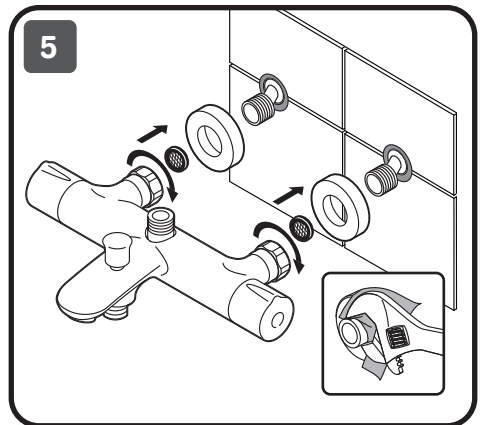
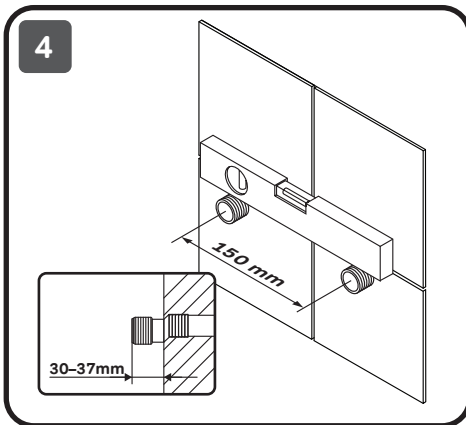
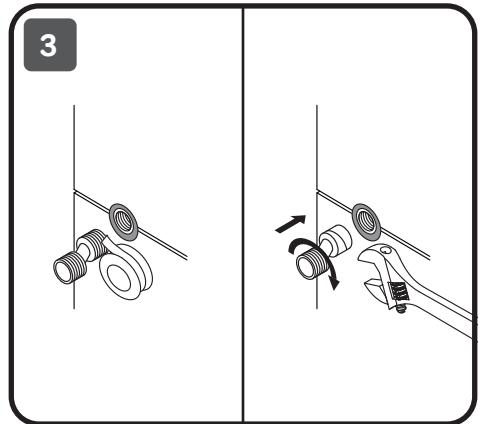
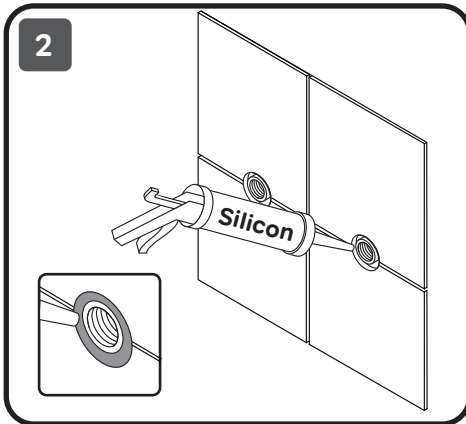
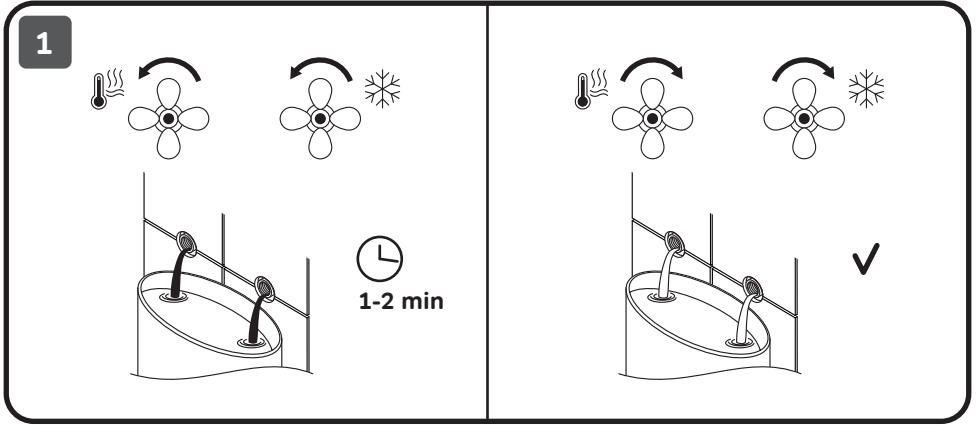

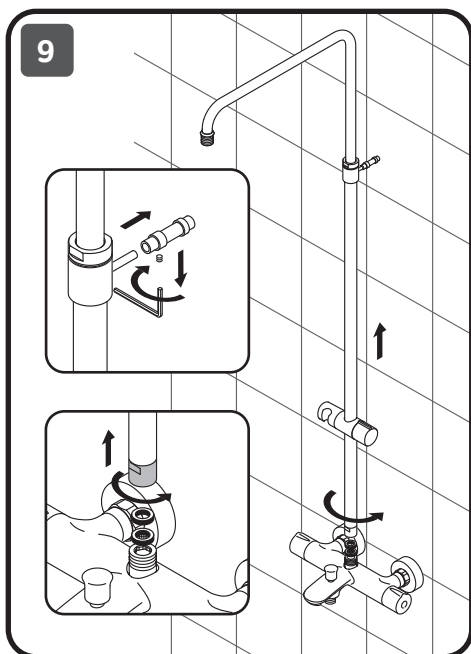
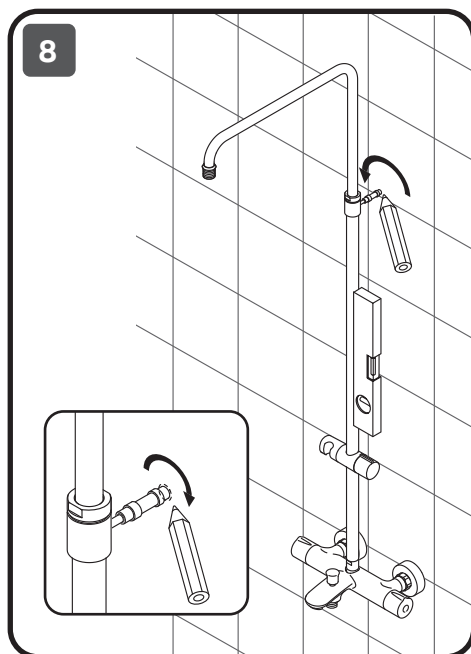
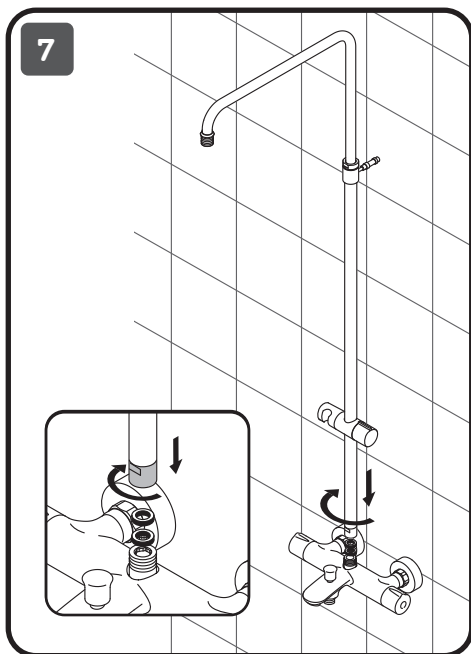
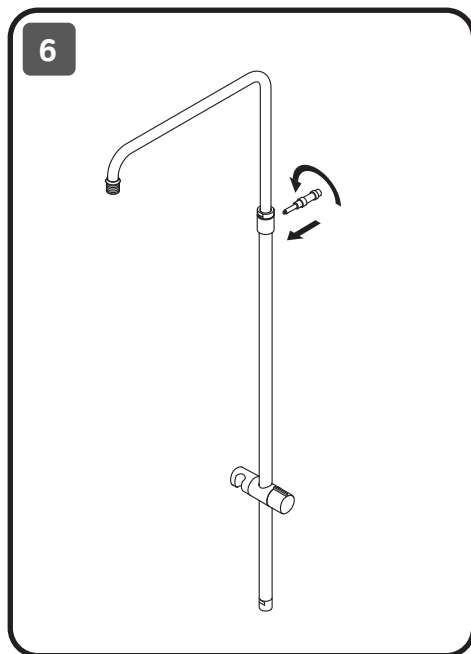

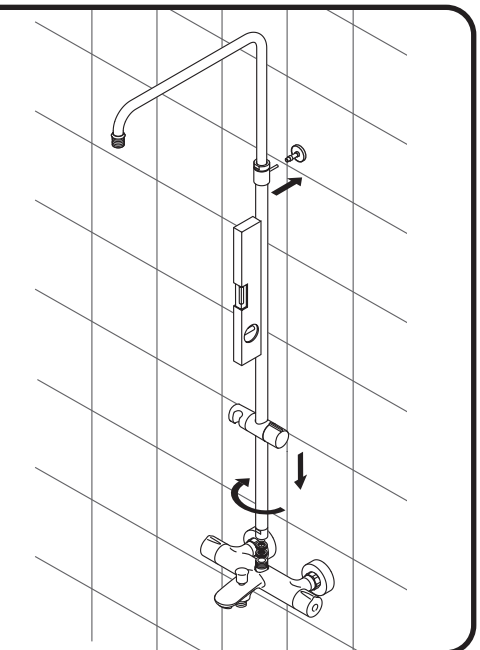
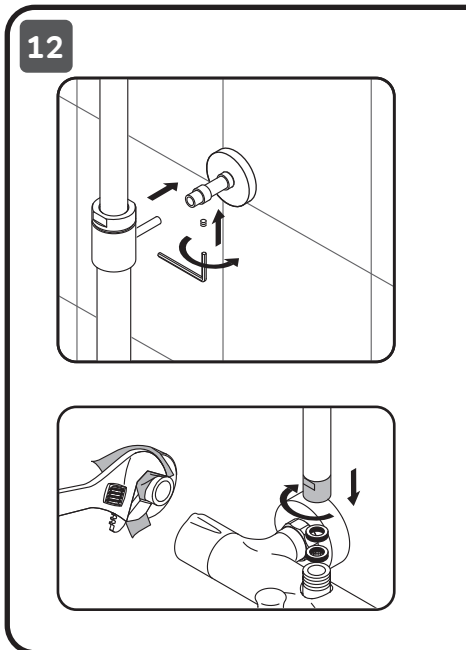
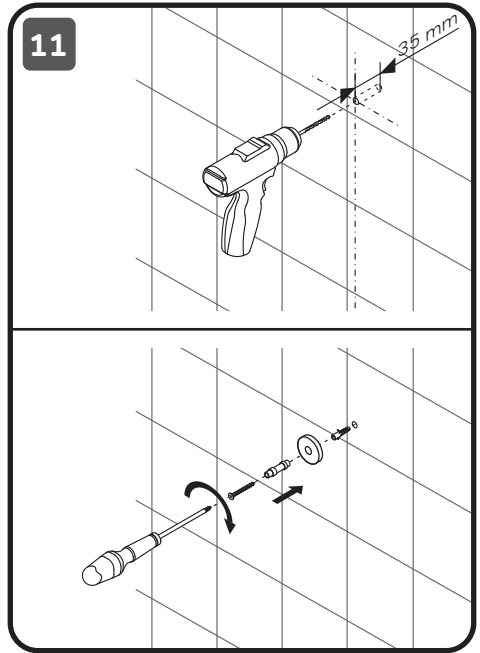
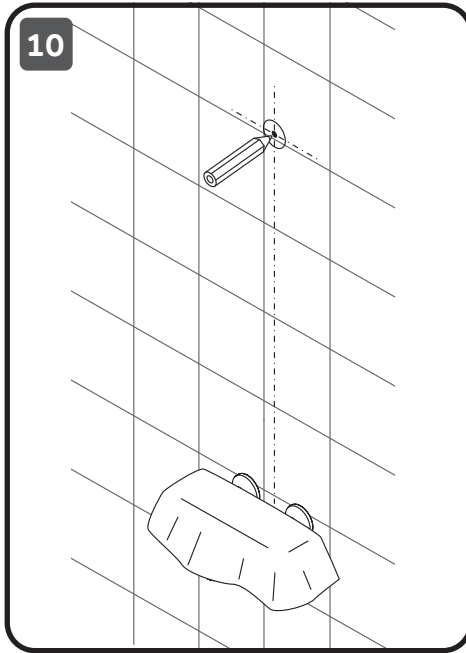

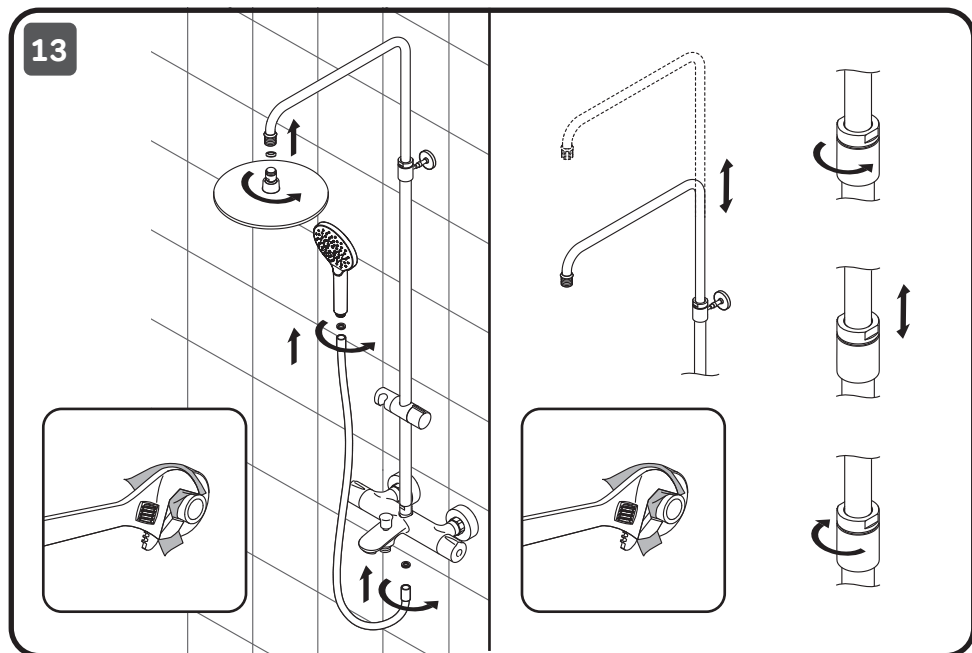

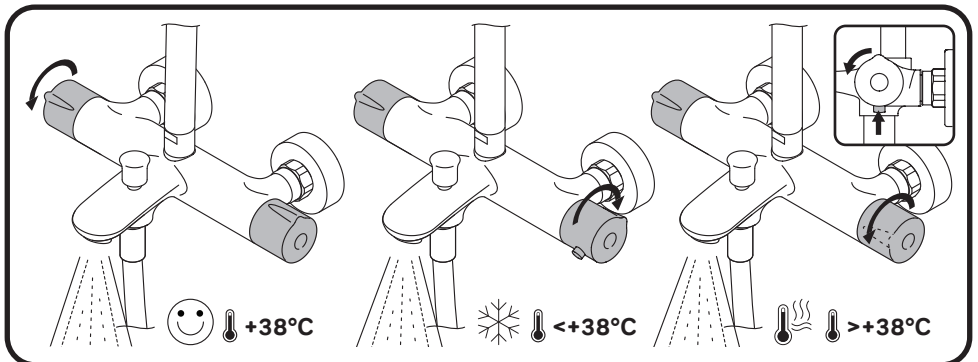
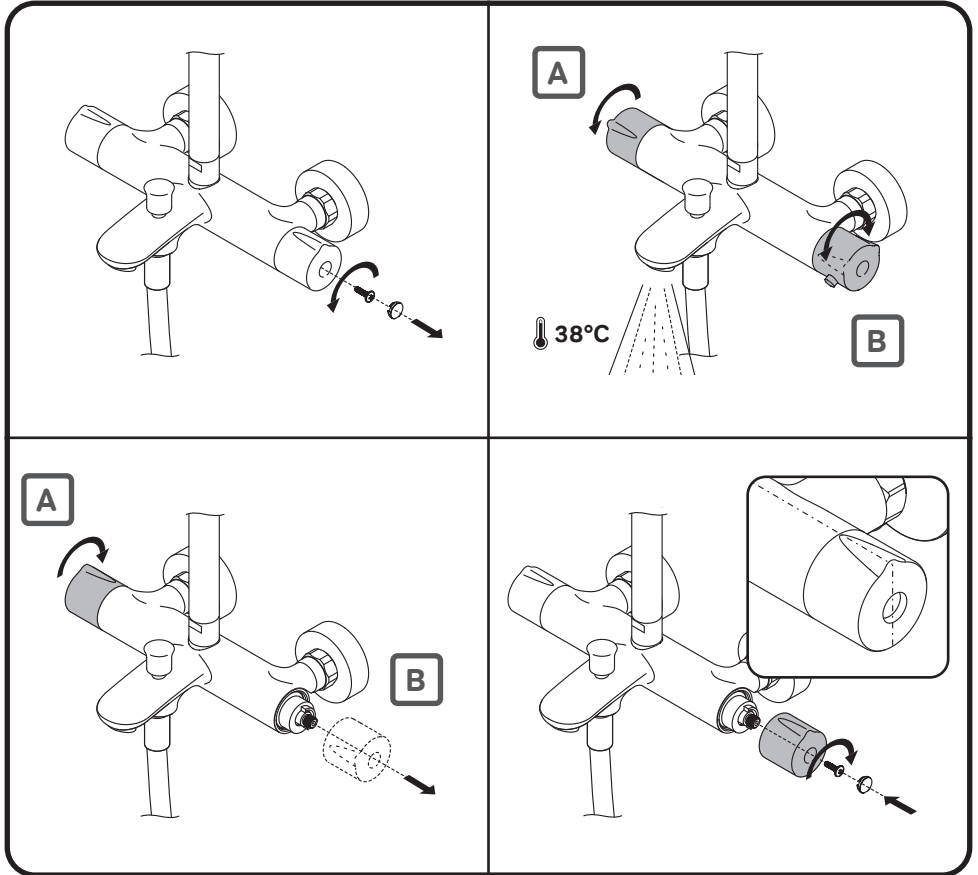

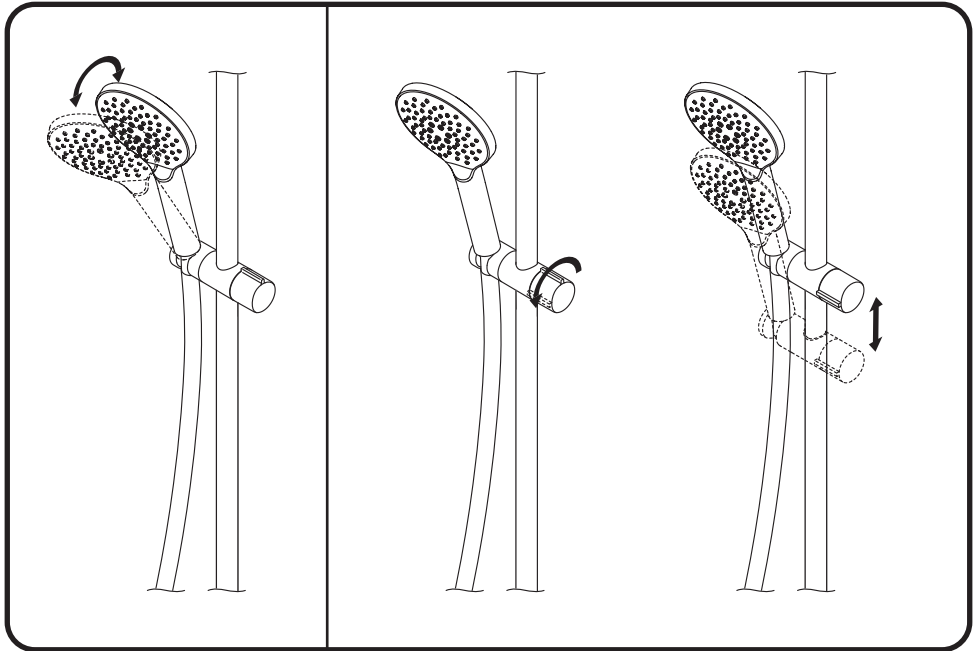
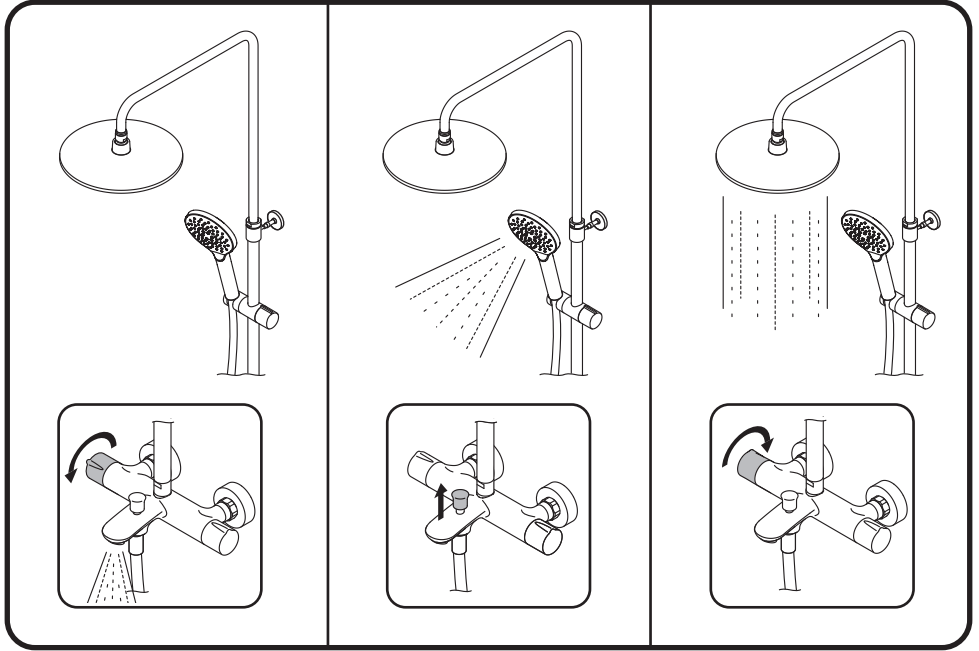

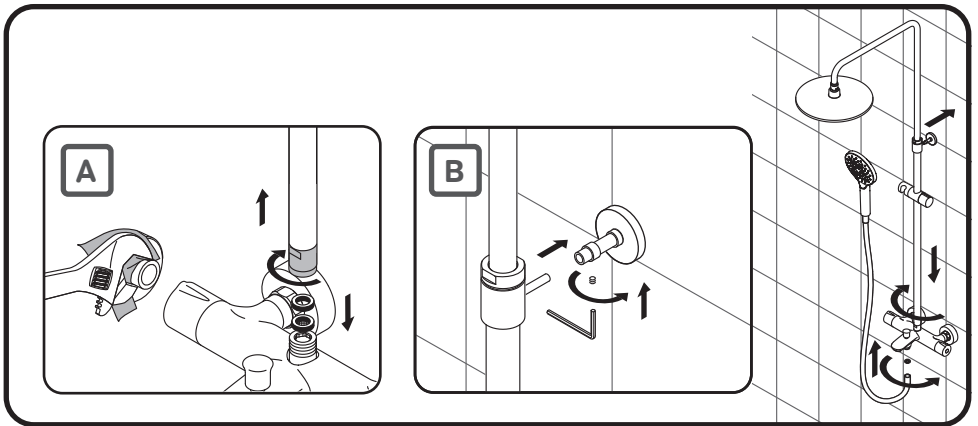
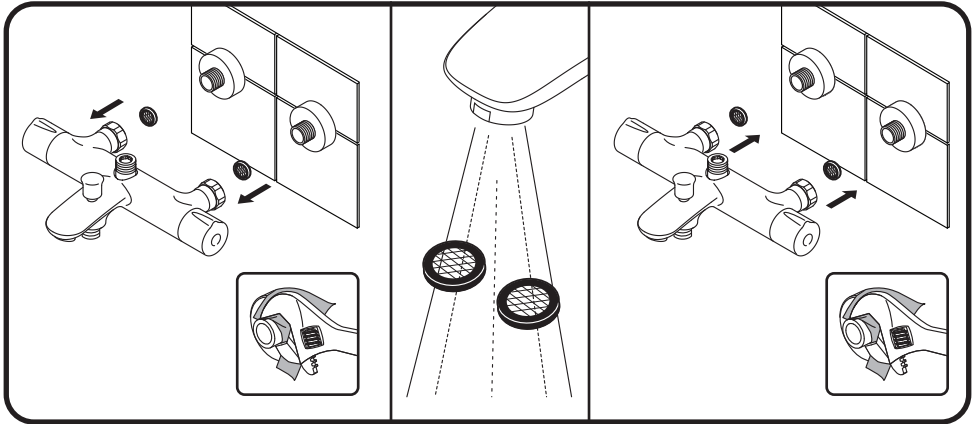
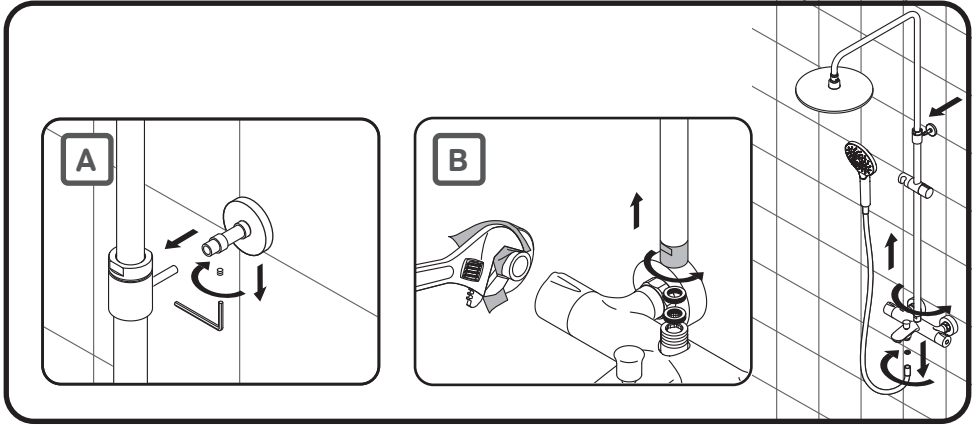

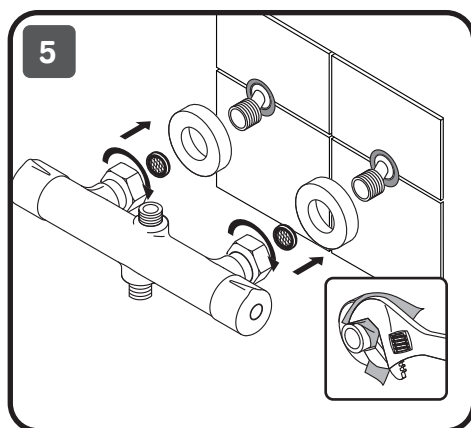
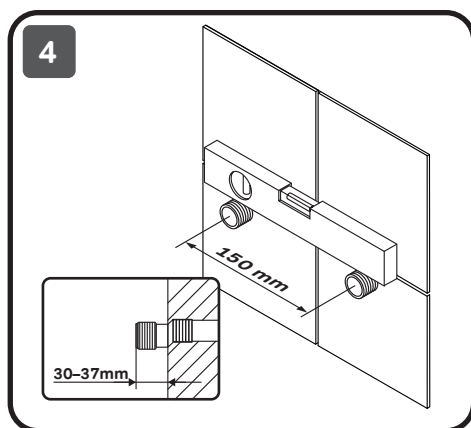
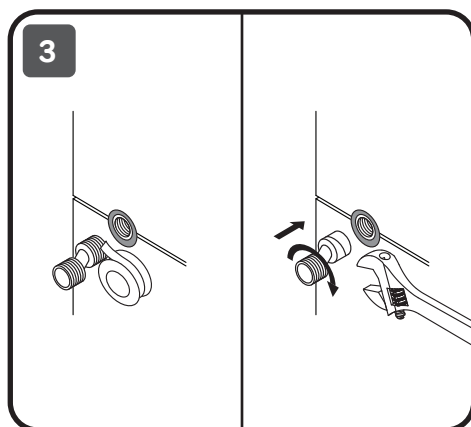
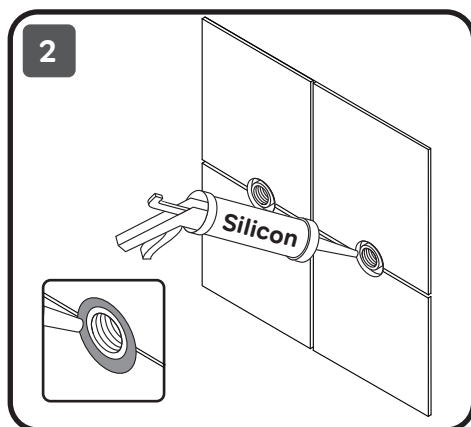
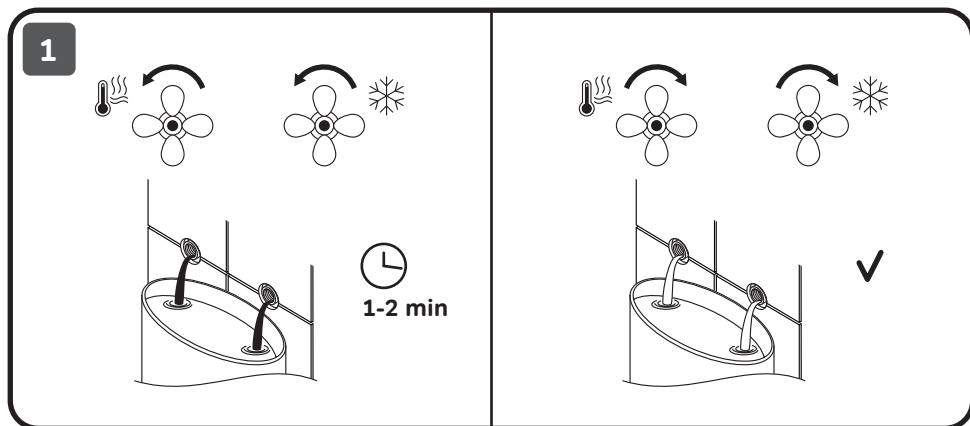

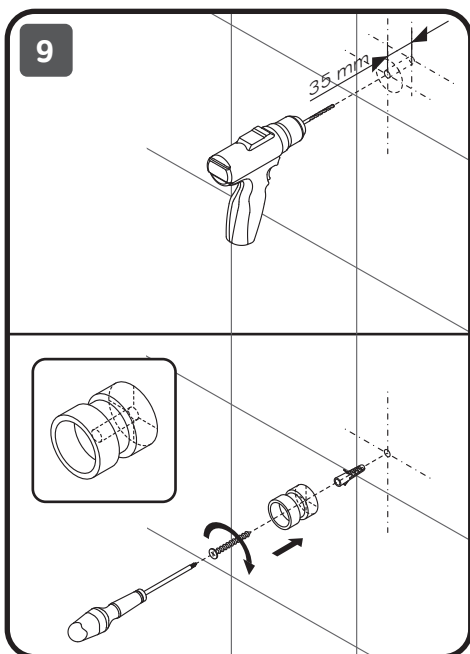
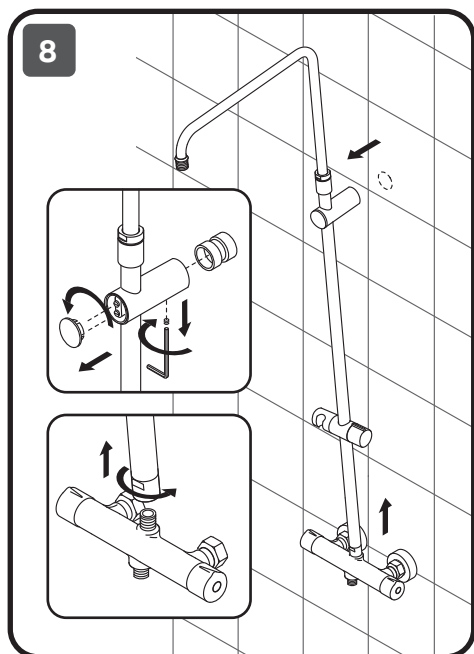
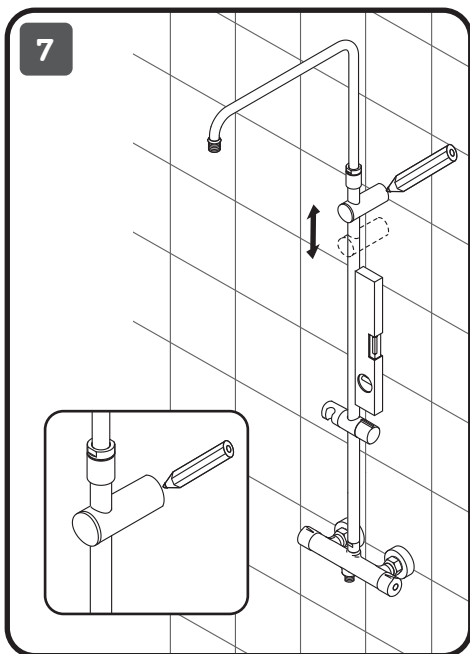
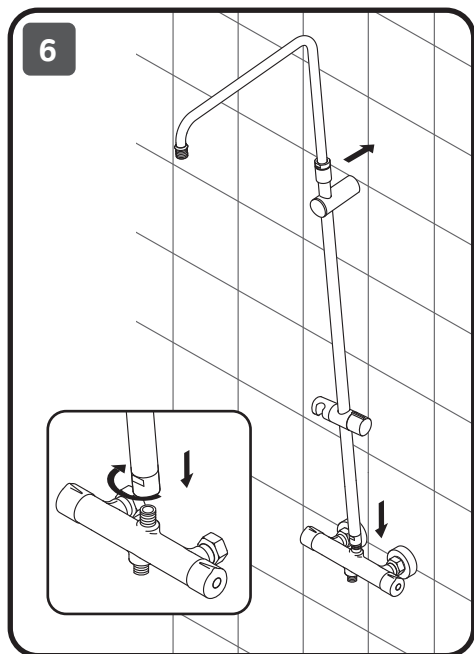

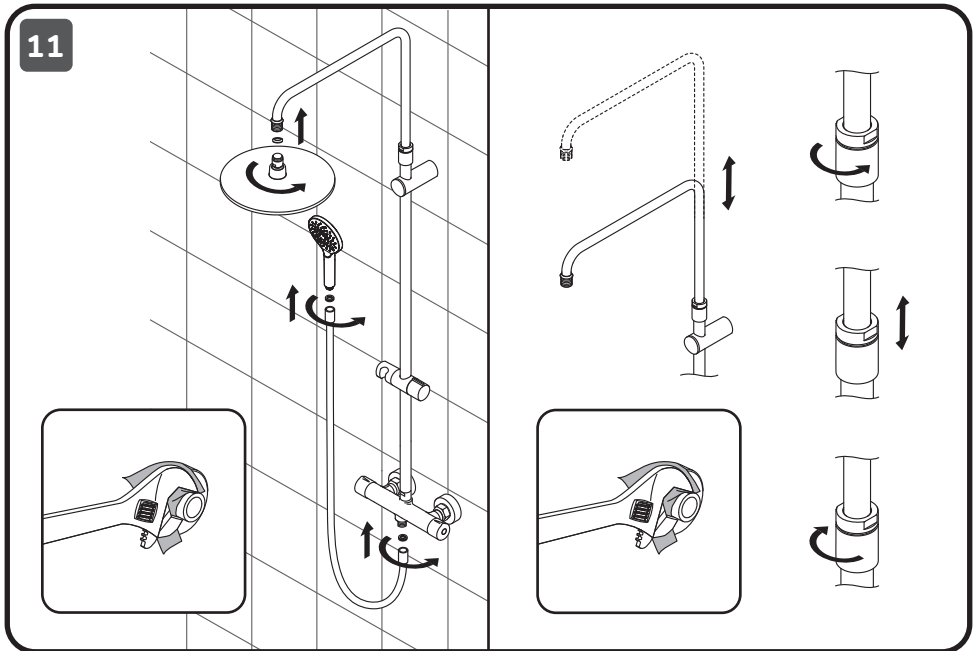
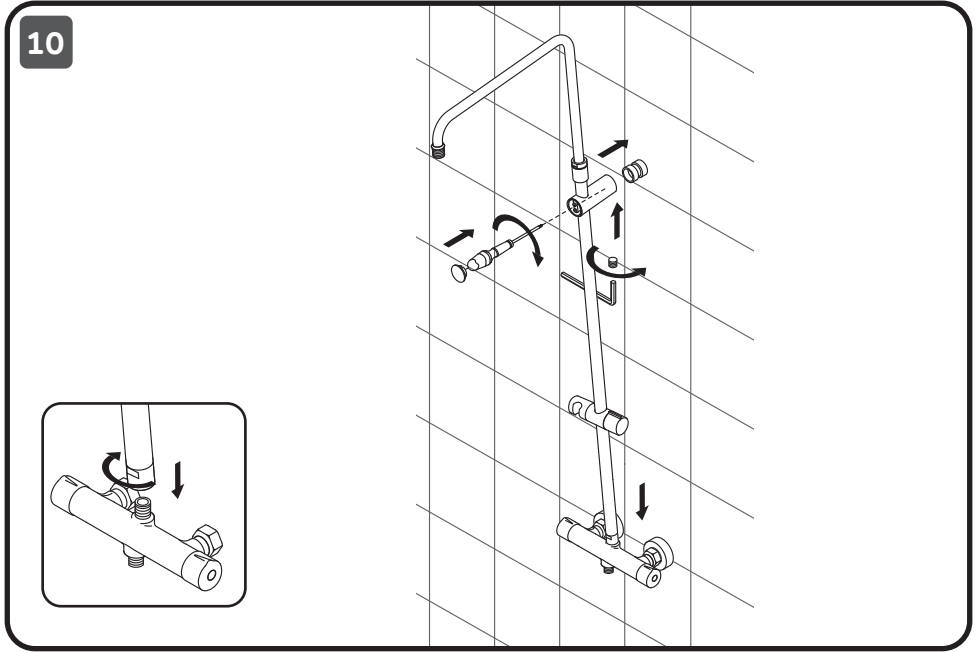

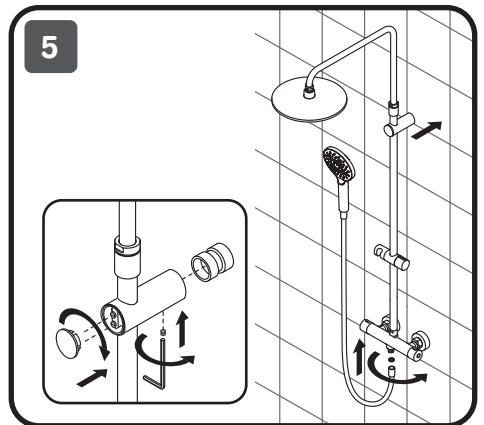
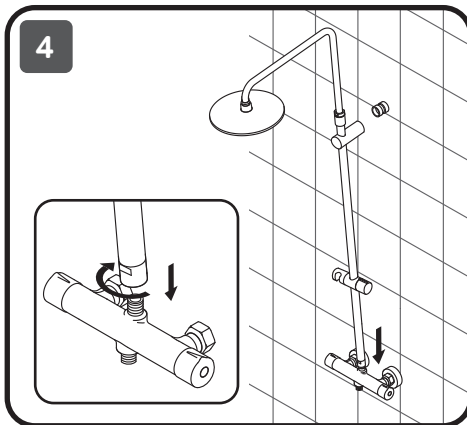
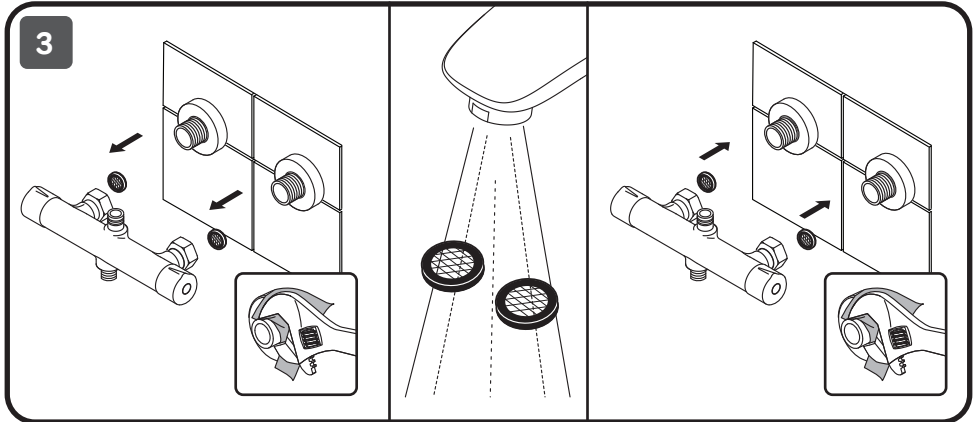
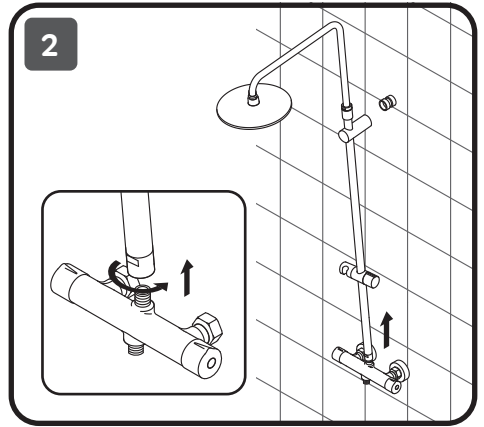
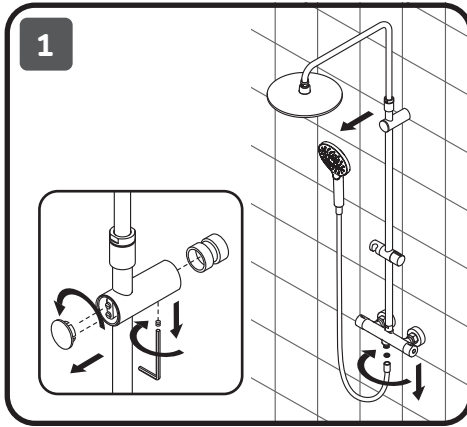

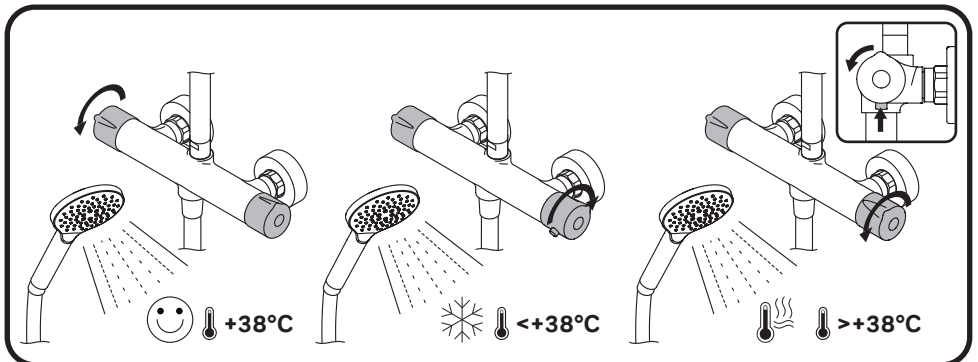
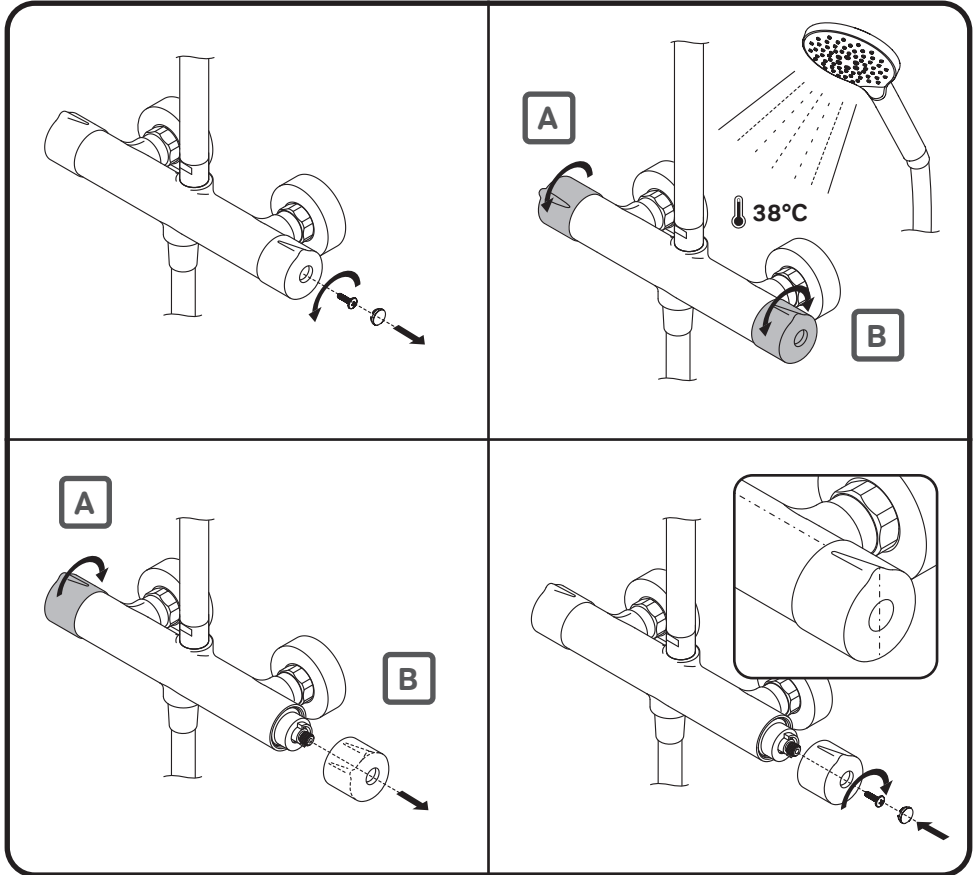

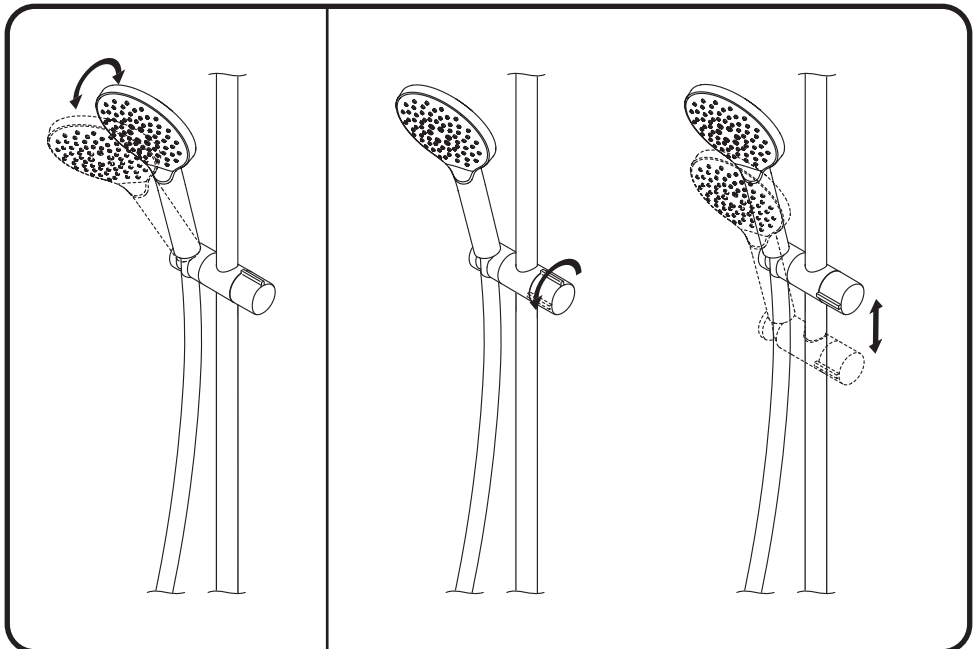
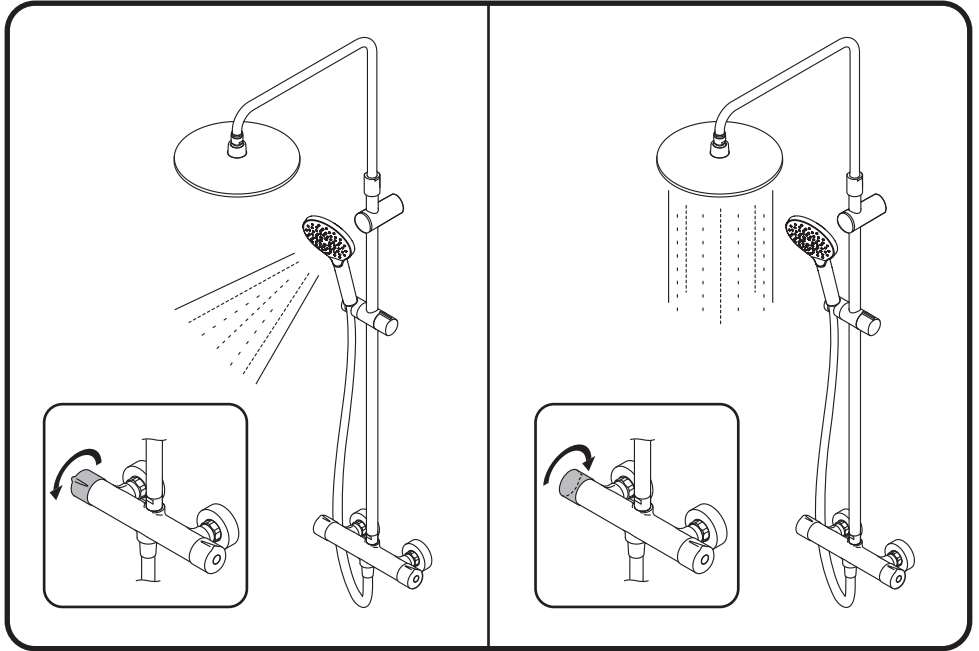

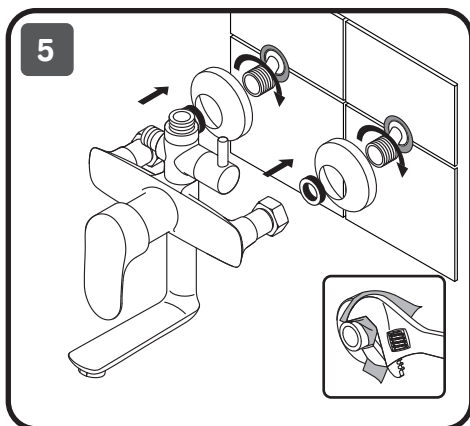
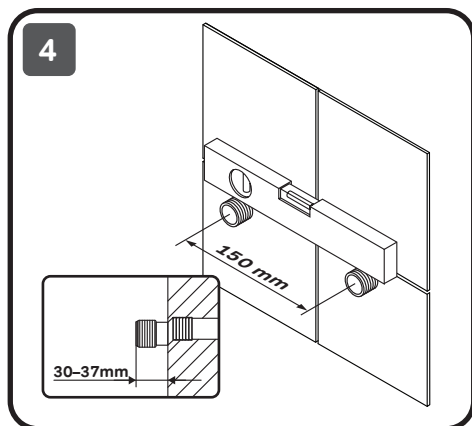
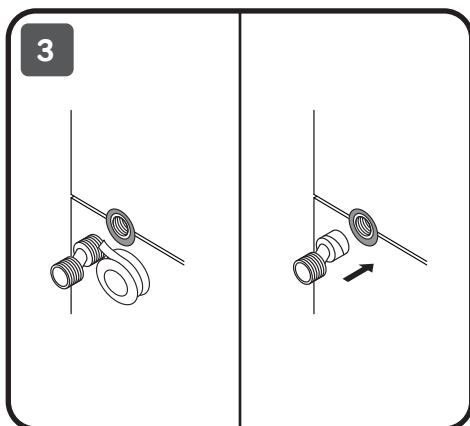
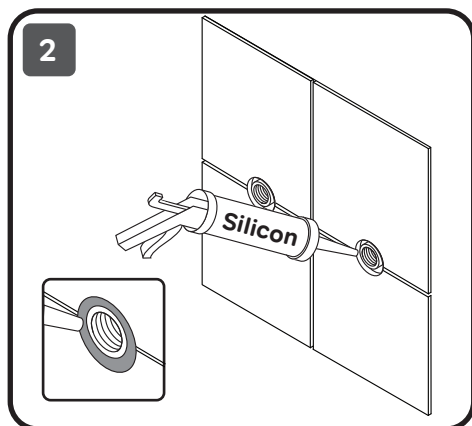
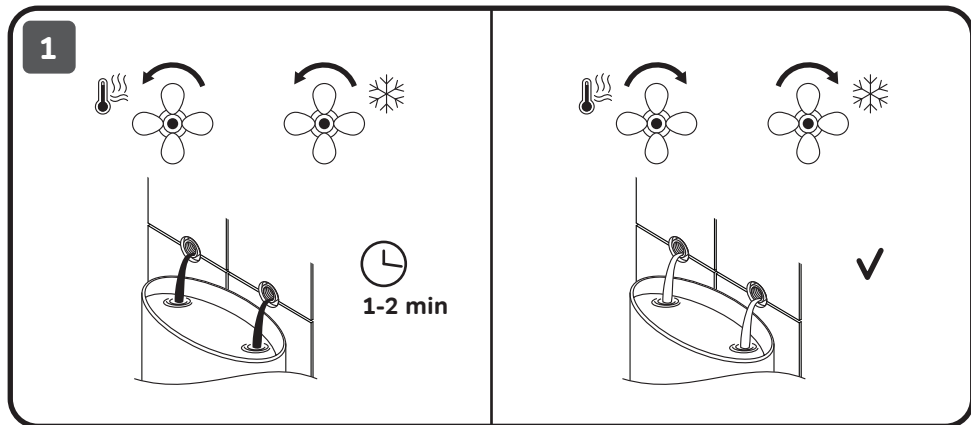

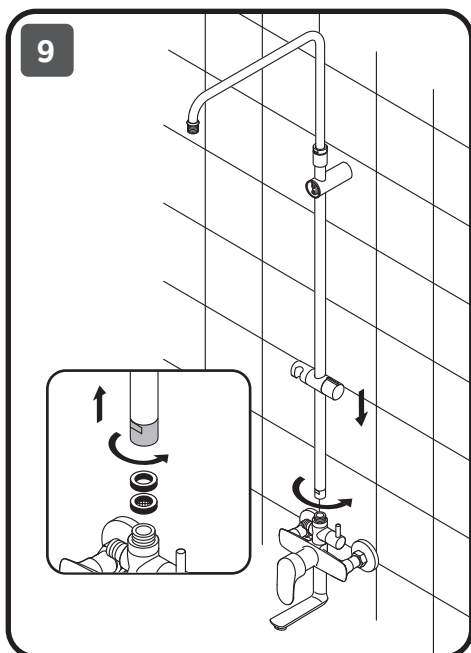
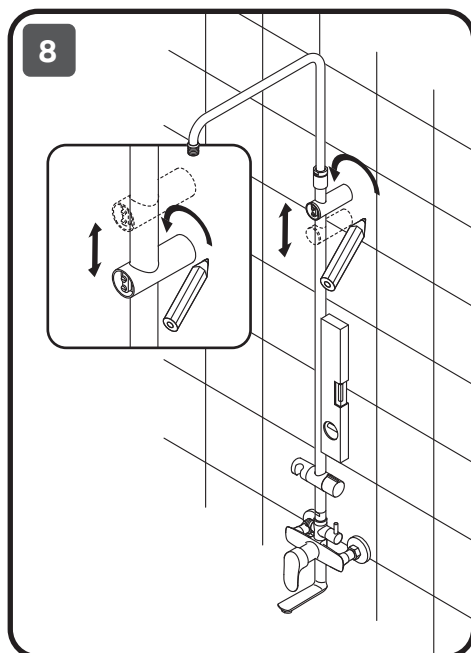
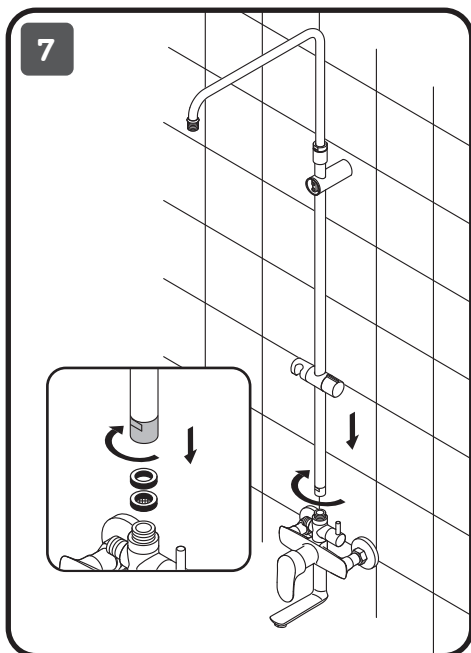
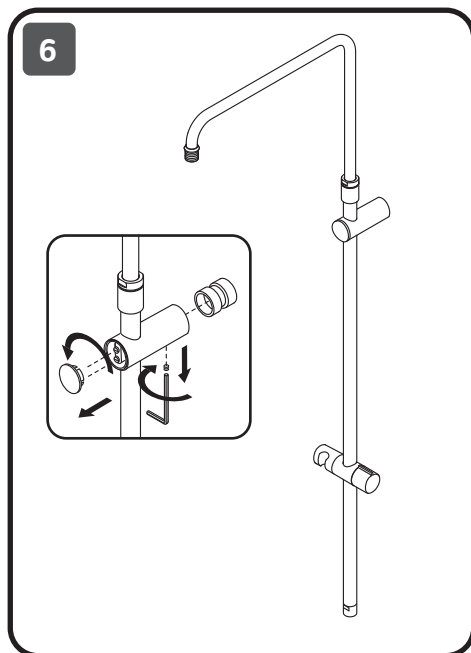

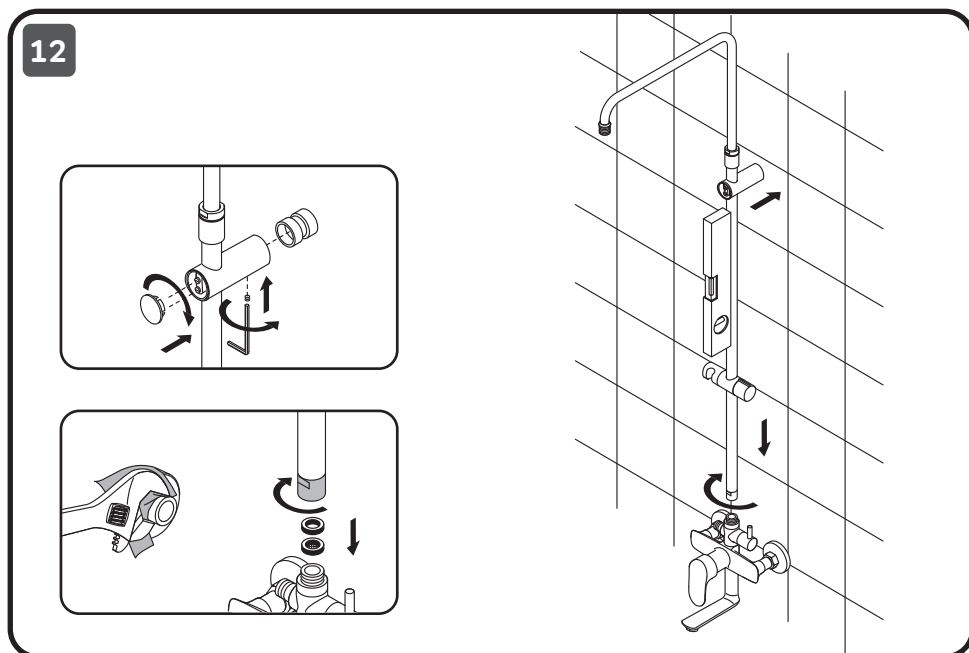
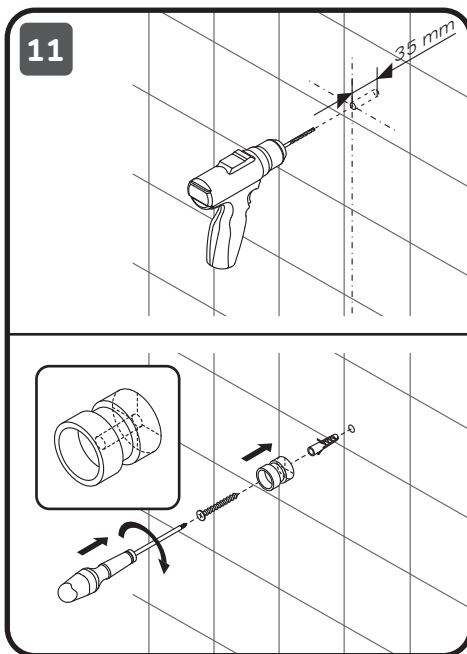
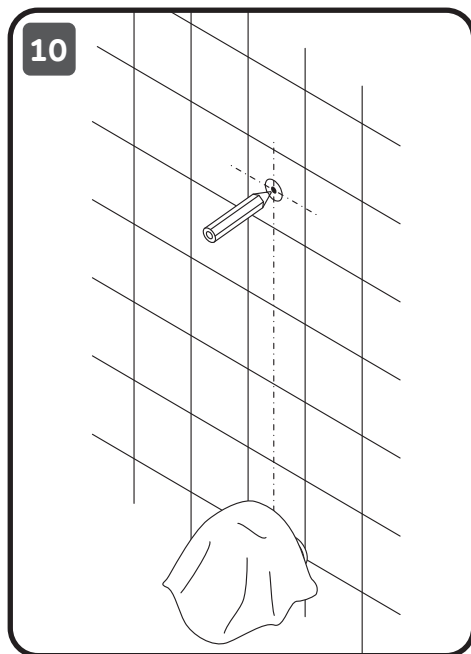

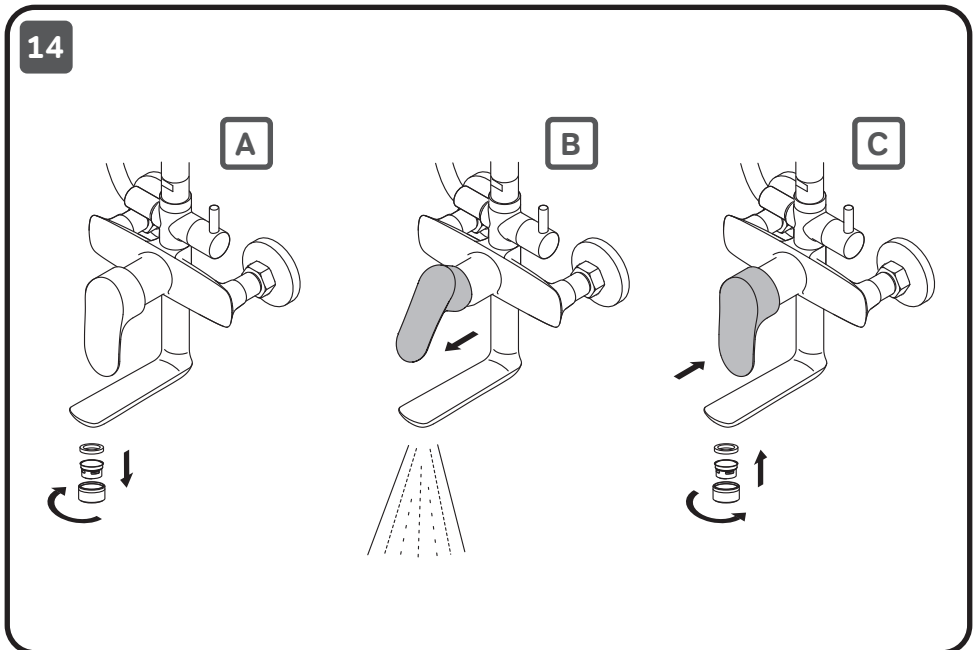
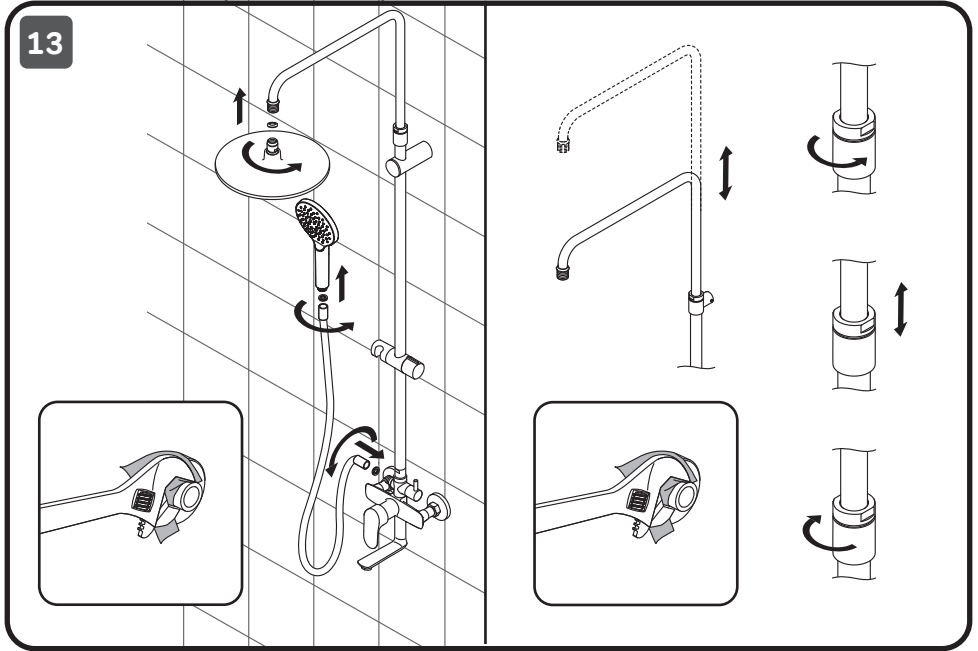

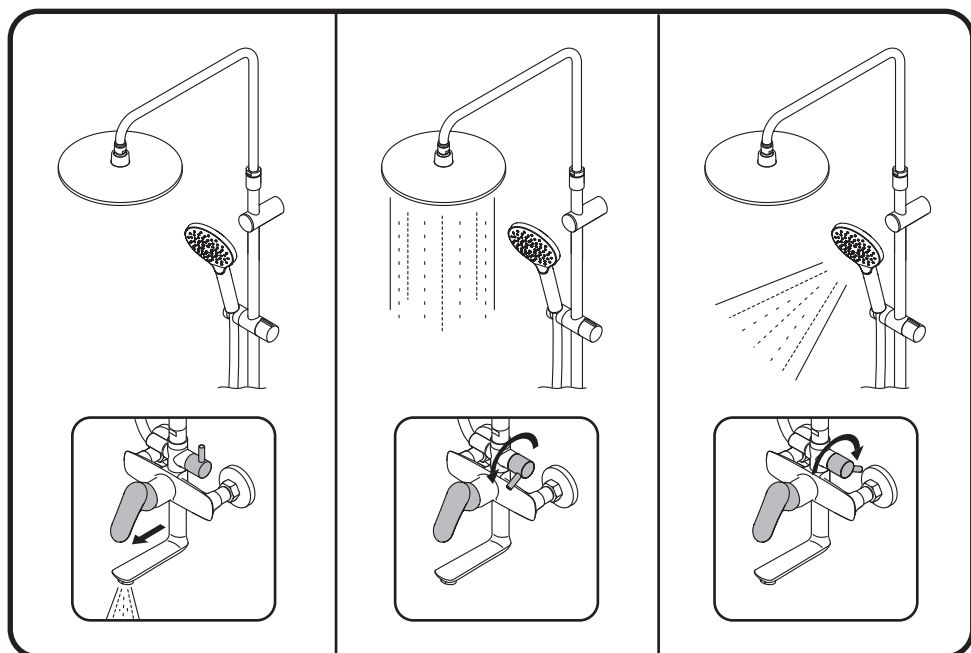
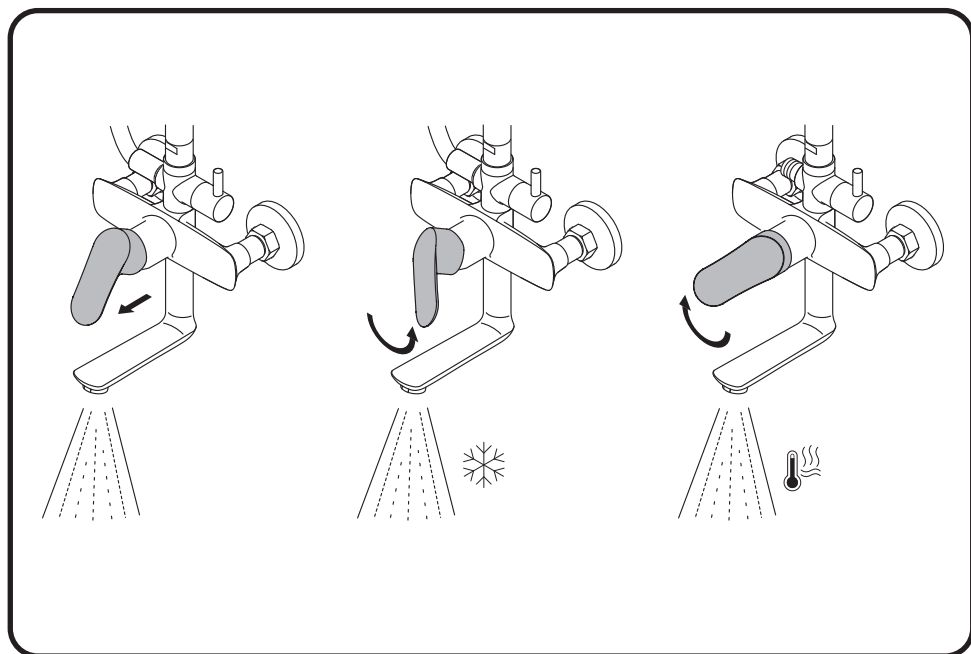

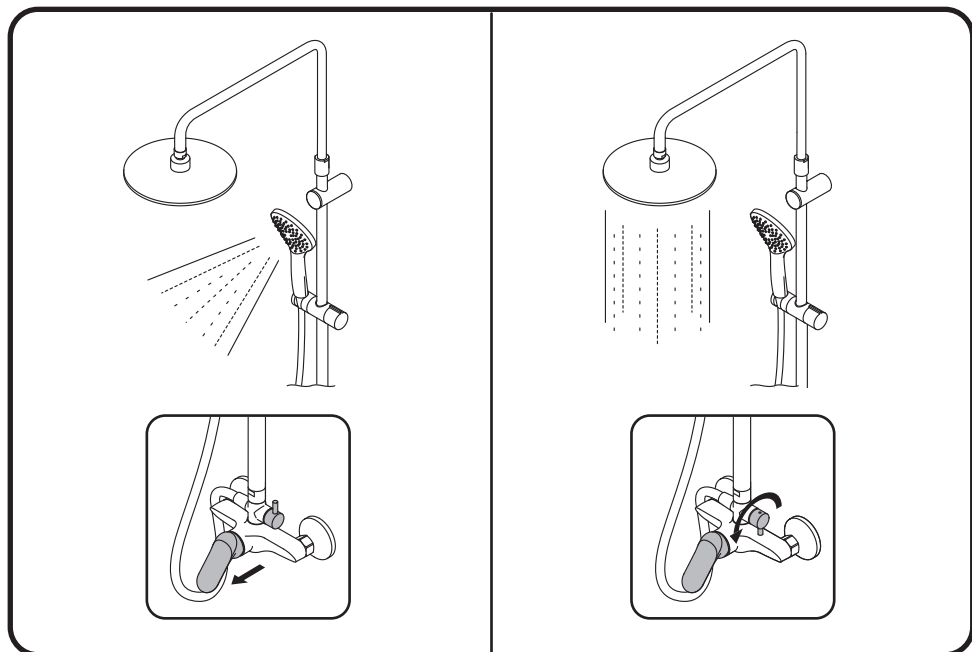
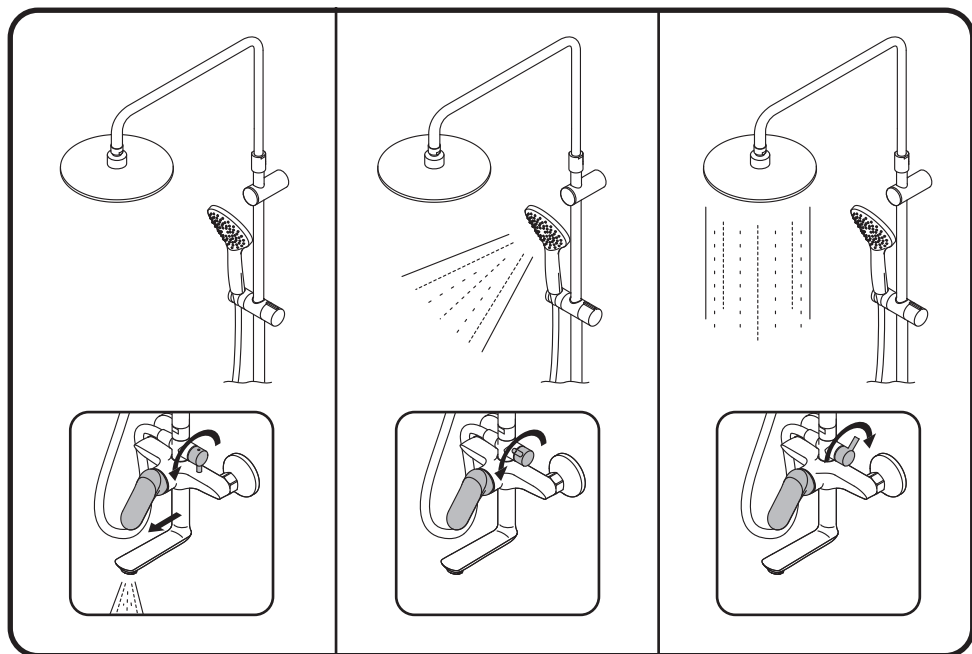

Like F0780964

Sunny F0785C900/22 / Sunny F0785C800/22

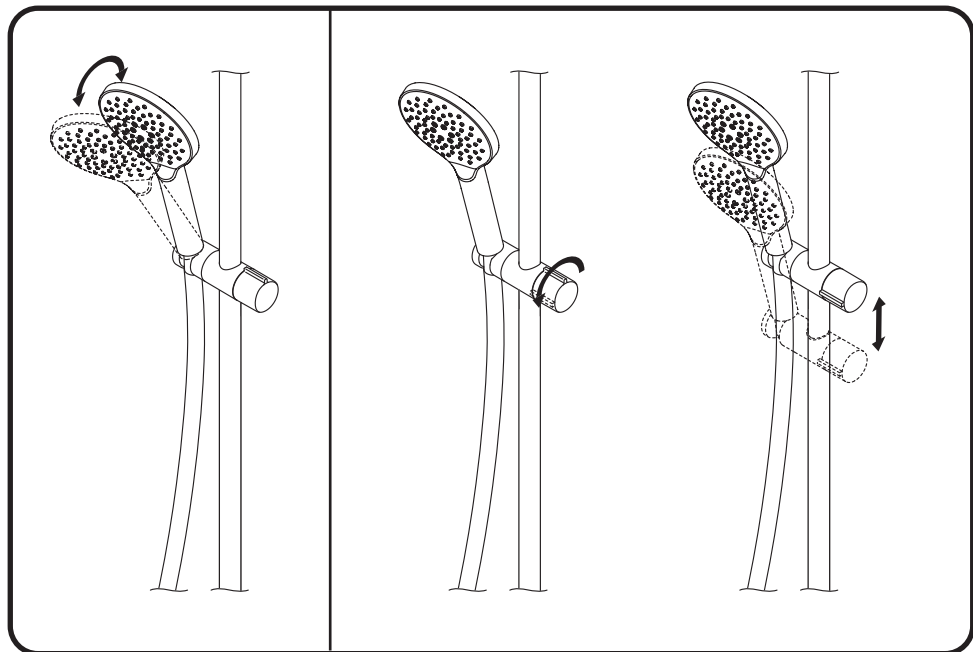

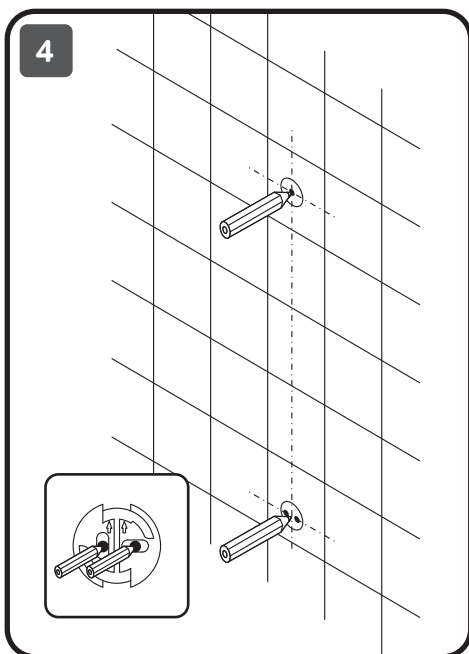
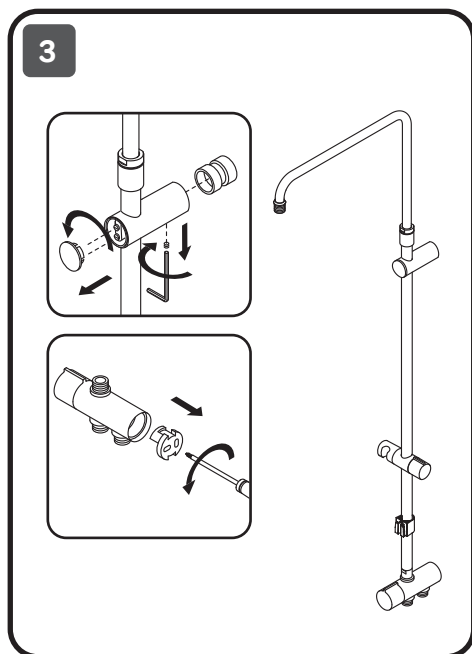
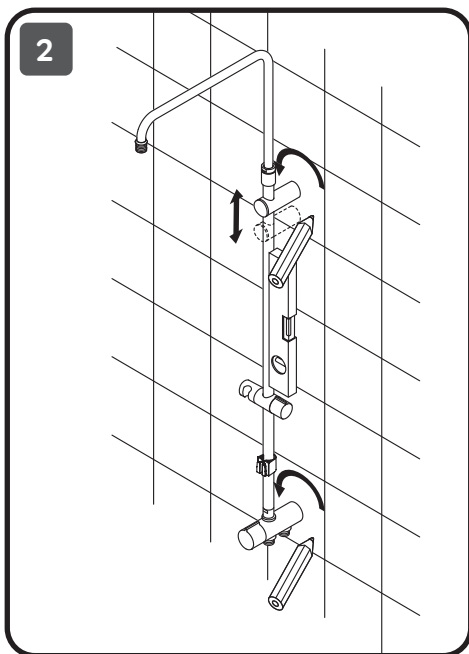
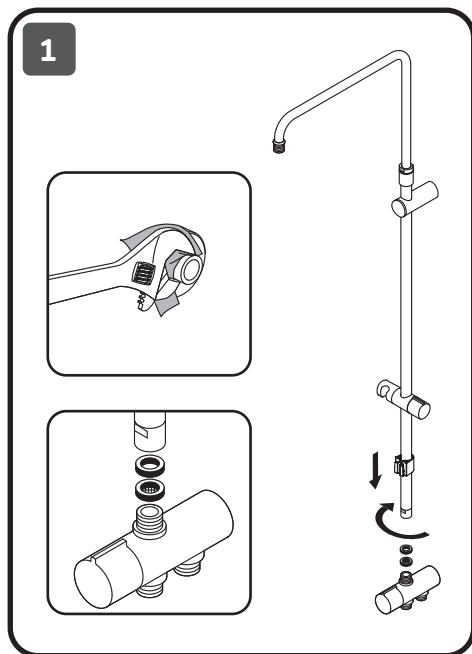

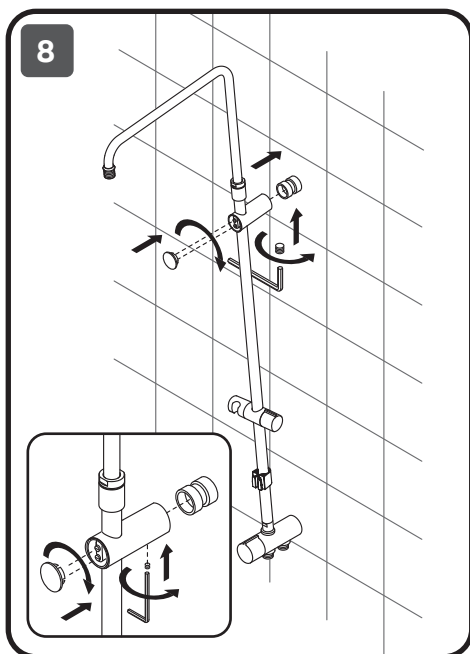
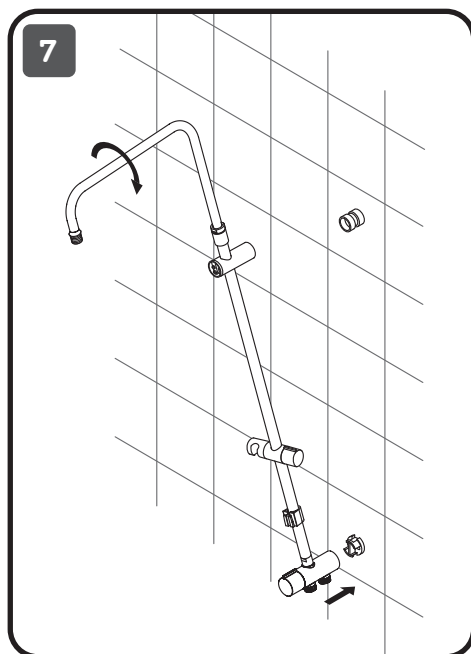
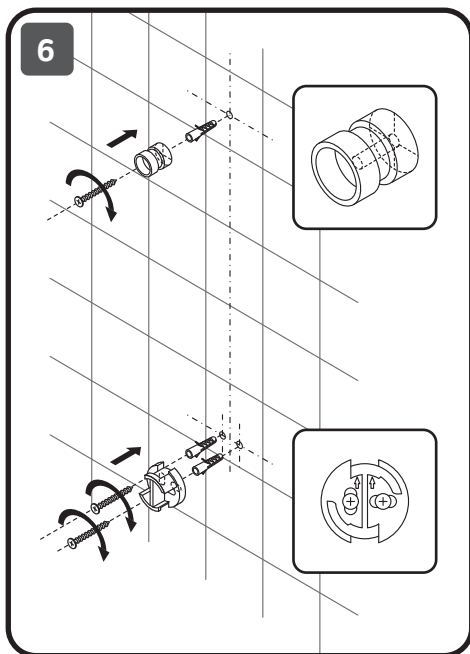
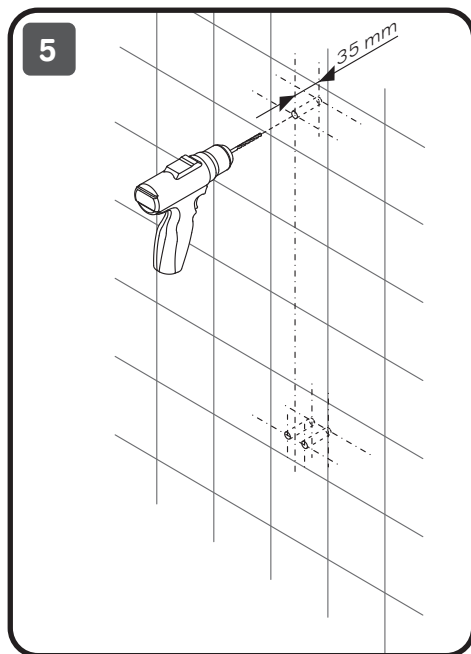

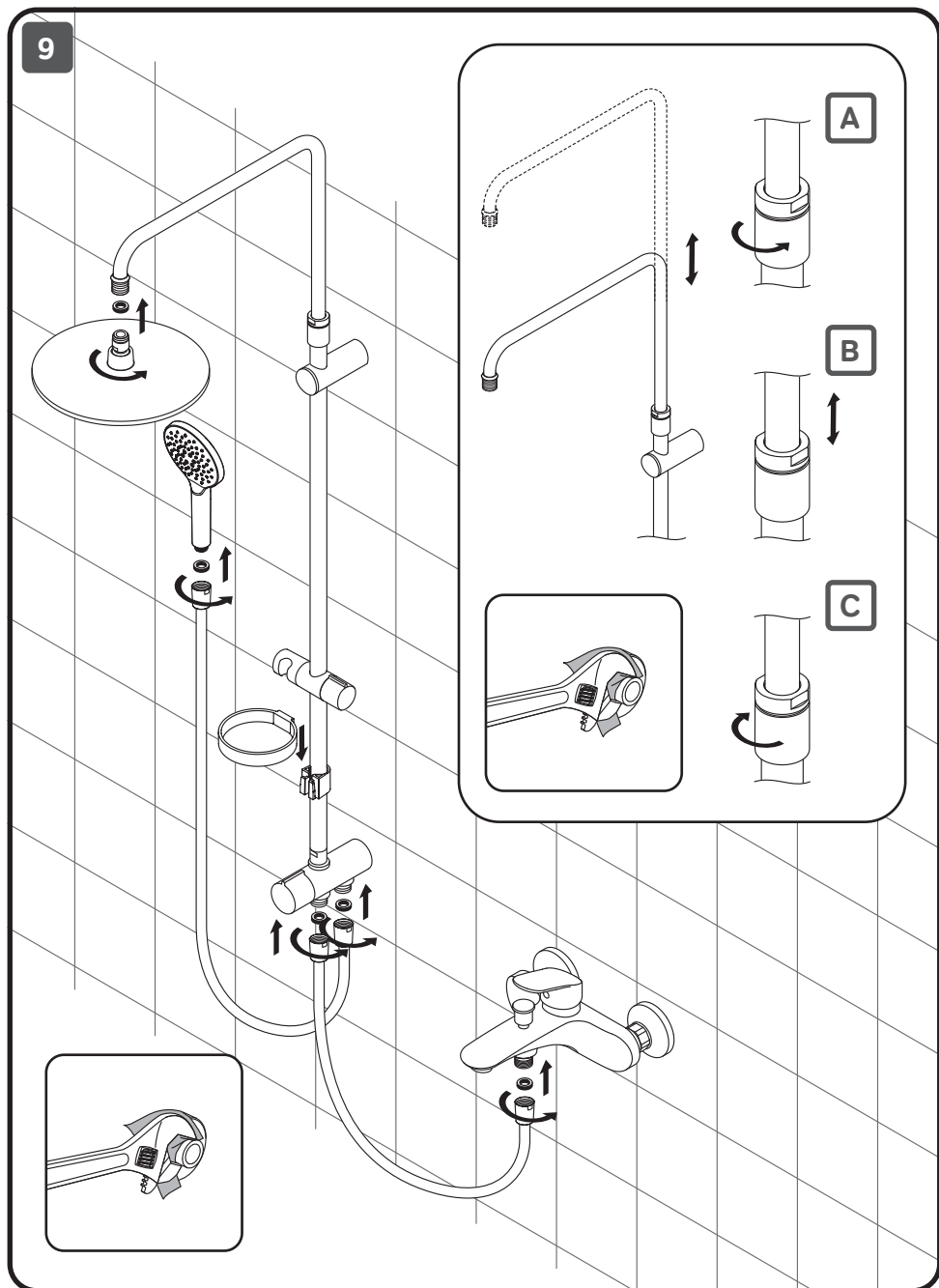

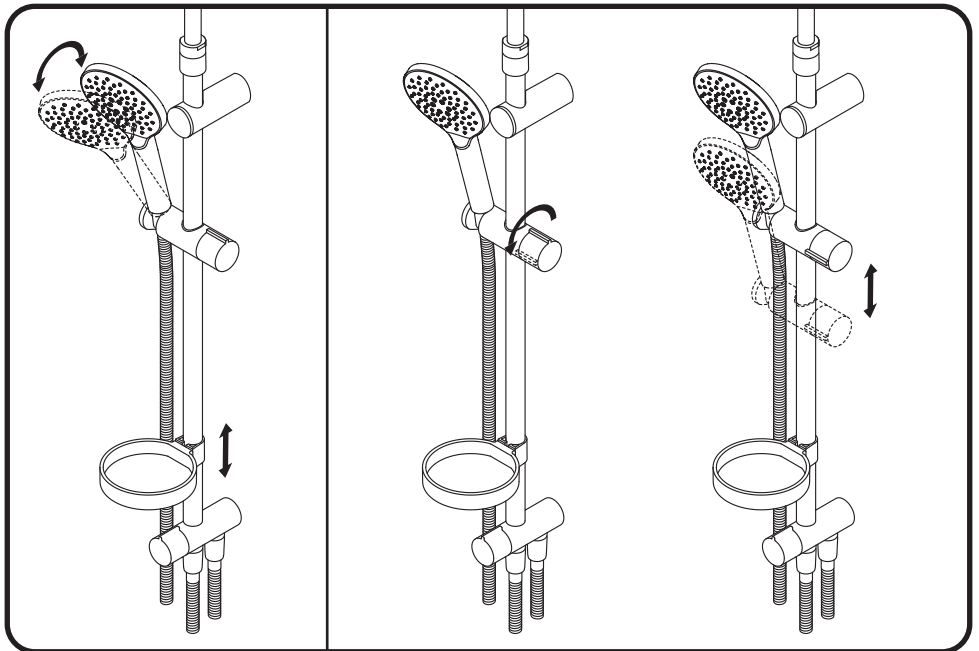
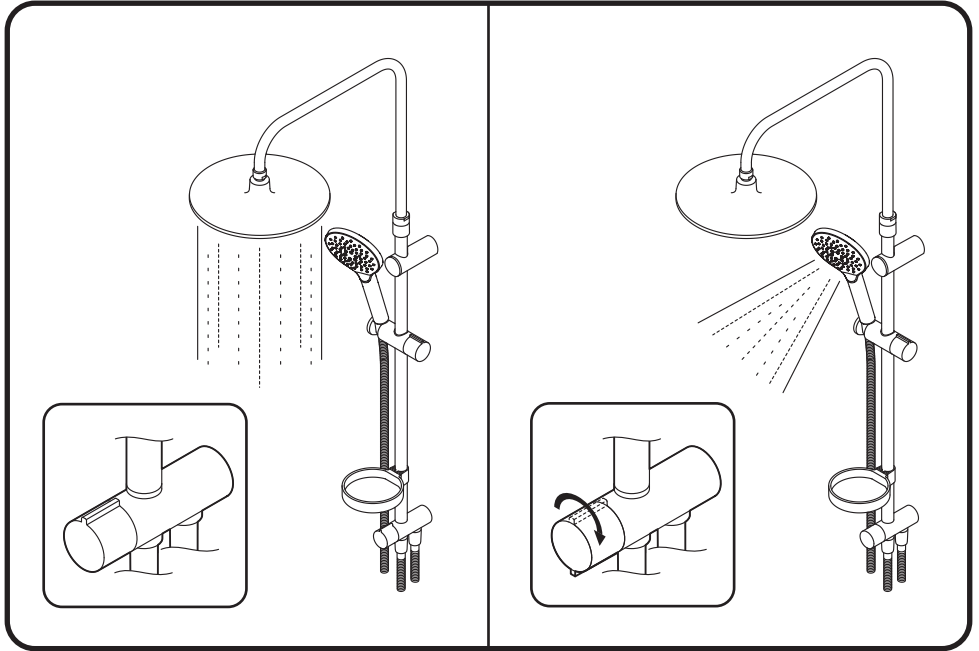



FUNCTIONS:



Spray



EnerJet



Spray+Massage

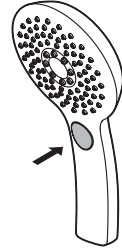

Inspire V2.0
F0750A400
F0750A500

FUNCTIONS:



Spray



EnerJet



Spray+Massage

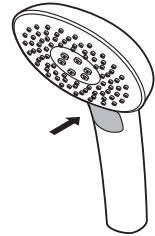

Spirit V2.0
F0770A400
F0770A500



FUNCTIONS:



Spray



EnerJet



Spray+Massage

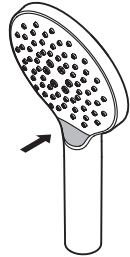

Like

F0780564/22

F0780464/22

F0780964

F0780064/22

FUNCTIONS:



Spray

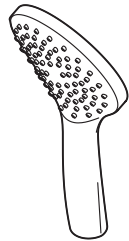

Gem

F0790000/22/33

Sunny

F0785C900/22

F0785C800/22

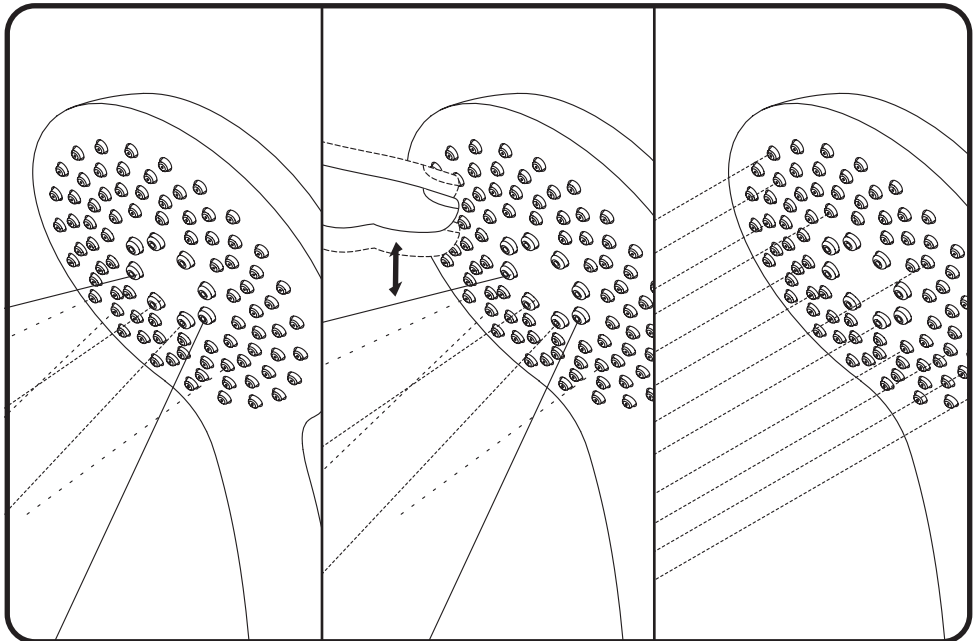
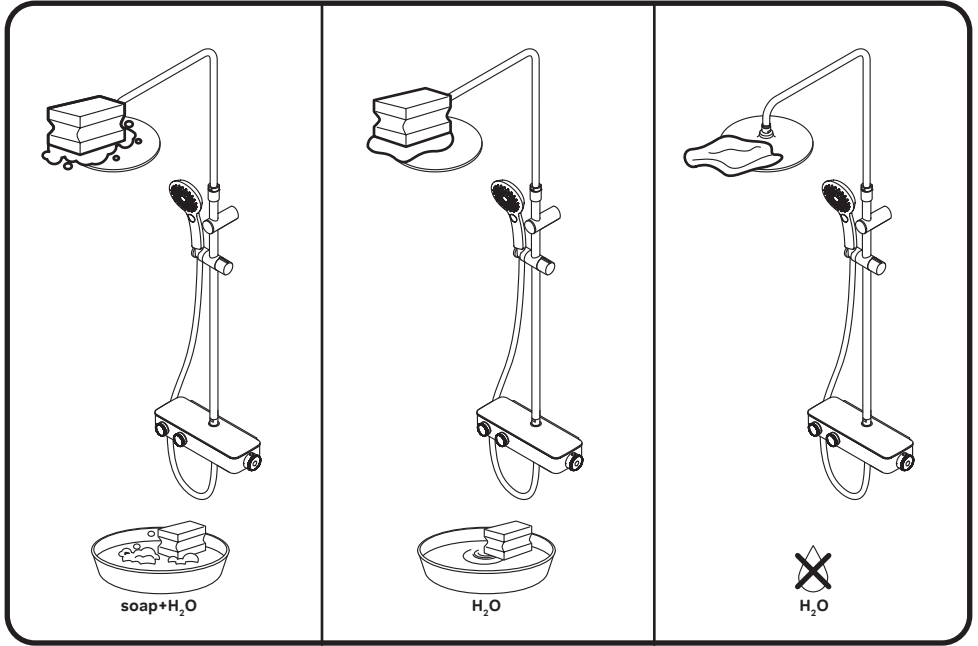



禁忌事項 / ACHTUNG / ATTENTION / TÄHELEPANU / DĚMESIO
UZMANĪBU / UWAGA / ВНИМАНИЕ / УВАГА

×

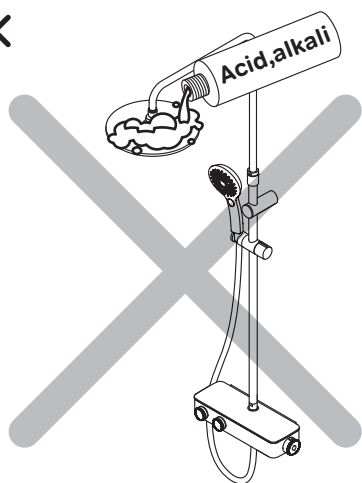

×

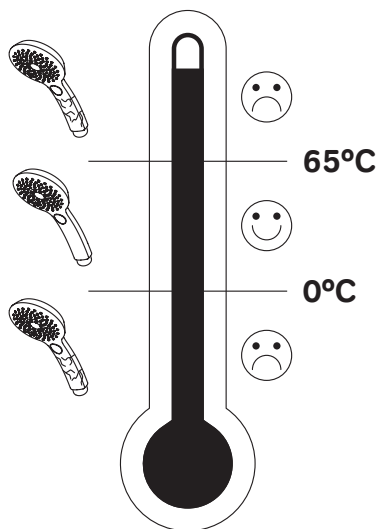
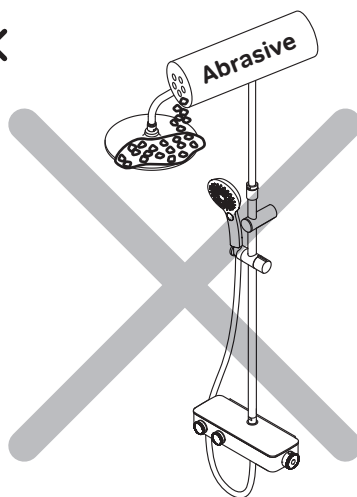

AM·PM

AM.PM Europe GmbH
Torstrasse 177 D-10115 Berlin
www.ampm-world.com 04/2021

ОФИЦИАЛЬНЫЙ ДИЛЕР В УКРАИНЕ:

storgom.ua

ГРАФИК РАБОТЫ:

Пн. – Пт.: с 8:30 по 18:30

Сб.: с 09:00 по 16:00

Вс.: с 10:00 по 16:00

КОНТАКТЫ:

+38 (044) 360-46-77

+38 (066) 77-395-77

+38 (097) 77-236-77

+38 (093) 360-46-77

Детальное описание товара:

<https://storgom.ua/product/am-pm-192537.html>

Другие товары: <https://storgom.ua/dusevye-sistemy.html>