

NOVA SALT W

SUBMERSIBLE PUMPS



TECHNICAL DATA

Operating range:

from 1 to 7.5 m³/h with head up to 6 metres.

Liquid temperature range:

from 0 °C to +35 °C for domestic use.

Pumped liquid: dirty water, without fibre, including salt water.

Max. immersion depth: 7 metres.

APPLICATIONS

The vertical delivery draining submersible pump has been specifically built for draining applications in salt water installations. It may also be used as a portable pump in emergency situations. The built-in float level switch, in the automatic version, allows fixed installation, ensuring automatic operation.

CONSTRUCTION FEATURES OF THE PUMP

Hydro resistant technopolymer pump body, cover, and suction grid.

AISI 316 stainless steel motor, rotor shaft, and bolts and screws.

Cable with tin plated conductors.

CONSTRUCTION FEATURES OF THE MOTOR

Submersible type continuous duty asynchronous motor.

Thermal overheating protection.

MATERIALS

N.	PARTS		MATERIALS
1	FILTER BASE		TECHNOPOLYMER
2	SUCTION STRAINER		TECHNOPOLYMER
3	OR RING		NBR
4	IMPELLER		TECHNOPOLYMER
5	V. RING		NBR
6	NUT		AISI 316 STAINLESS STEEL DIN 982
7	WASHER		A2 STAINLESS STEEL
8	MOTOR	CASE	ALUMINIUM
		ROTOR SHAFT	AISI 316 STAINLESS STEEL UNI EN 10088-1 X5CRNIMO1712-2
9	BODY		TECHNOPOLYMER
10	OR RING		NBR

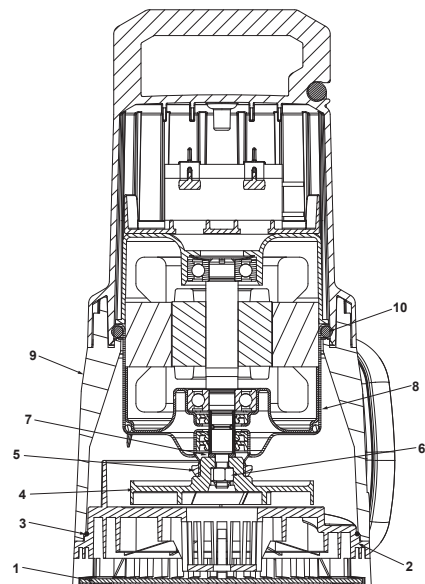

NOVA SALT W - SALT WATER SUBMERSIBLE PUMPS

Liquid temperature range: from 0 °C to +35 °C for domestic use

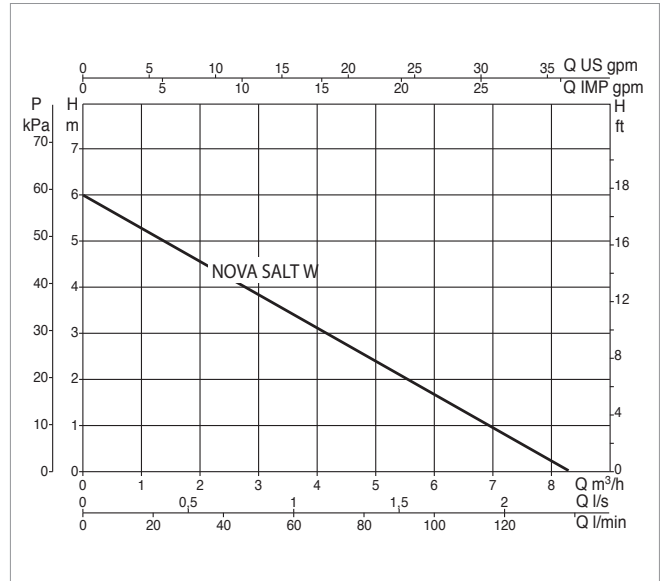
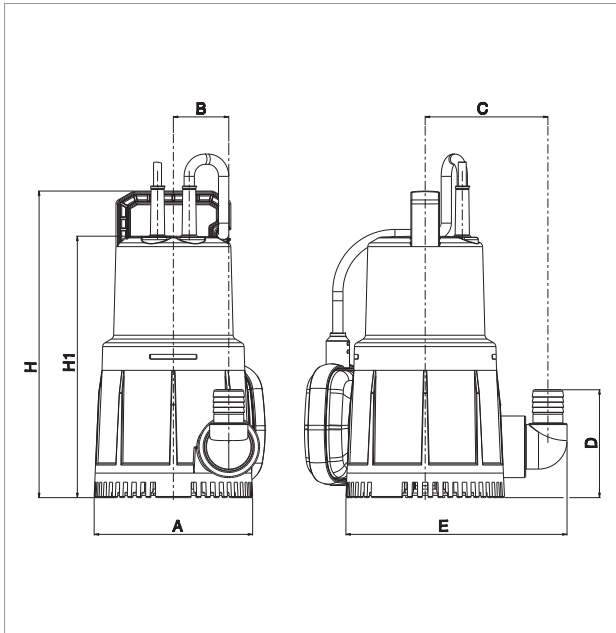

The performance curves are based on kinematic viscosity values = 1 mm²/s and density equal to 1000 kg/m³. Curve tolerance according to ISO 9906.

MODEL	Q=m ³ /h	0	1	2	3	4,5	5	6	7	7,5
	Q=l/min	0	16,6	33,3	50	75	83,3	100	116,6	125
NOVA SALT W M-A	H (m)	6	5,4	4,7	3,9	2,8	2,5	1,7	1	0,5

MODEL	ELECTRICAL DATA				
	POWER INPUT 50 Hz	P1 MAX kW	P2 NOMINAL		In A
			kW	HP	
NOVA SALT W M-A	1 x 230V ~	0,28	0,2	0,28	1,3

MODEL	A	B	C	D	E	H	H1	DNM GAS	PACKING DIMENSIONS			CABLE	VOLUME (m ³)	WEIGHT kg
									L/A	L/B	H			
NOVA SALT W M-A	140	48	107	95	195	270	230	1" ^{1/4}	193	193	330	10 mt.	0,012	3,9

SALT WATER PUMP

ОФИЦИАЛЬНЫЙ ДИЛЕР В УКРАИНЕ:

storgom.ua

ГРАФИК РАБОТЫ:

Пн. – Пт.: с 8:30 по 18:30

Сб.: с 09:00 по 16:00

Вс.: с 10:00 по 16:00

КОНТАКТЫ:

+38 (044) 360-46-77

+38 (066) 77-395-77

+38 (097) 77-236-77

+38 (093) 360-46-77

Детальное описание товара:

<https://storgom.ua/product/drenazhnyi-nasos-dab-nova-salt-w-m-a-601226-2.html>

Другие товары: <https://storgom.ua/drenazhnye-nasosy.html>