

DE	Gebrauchsanleitung / Montageanleitung	2
FR	Mode d'emploi / Instructions de montage	3
EN	Instructions for use / assembly instructions	4
IT	Istruzioni per l'uso / Istruzioni per Installazione	5
ES	Modo de empleo / Instrucciones de montaje	6
NL	Gebruiksaanwijzing / Handleiding	7
DK	Brugsanvisning / Monteringsvejledning	8
PT	Instruções para uso / Manual de Instalação	9
PL	Instrukcja obsługi / Instrukcja montażu	10
CS	Návod k použití / Montážní návod	11
SK	Návod na použitie / Montážny návod	12
ZH	用户手册 / 组装说明	13
RU	Руководство пользователя / Инструкция по монтажу	14
HU	Használati útmutató / Szerelési útmutató	15
FI	Käyttöohje / Asennusohje	16
SV	Bruksanvisning / Monteringsanvisning	17
LT	Vartotojo instrukcija / Montavimo instrukcijos	18
HR	Upute za uporabu / Uputstva za instalaciju	19
TR	Kullanım kılavuzu / Montaj kılavuzu	20
RO	Manual de utilizare / Instrucțiuni de montare	21
EL	Οδηγίες χρήσης / Οδηγία συναρμολόγησης	22
SL	Navodilo za uporabo / Navodila za montažo	23
ET	Kasutusjuhend / Paigaldusjuhend	24
LV	Lietošanas pamācība / Montāžas instrukcija	25
SR	Uputstvo za upotrebu / Uputstvo za montažu	26
NO	Bruksanvisning / Montasjeveiledning	27
BG	Инструкция за употреба / Ръководство за монтаж	28
SQ	Udhëzuesi i përdorimit / Udhëzime rreth montimit	29
AR	دليل الاستخدام / تعليمات التجميع	30

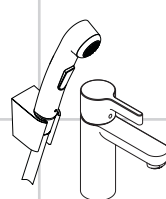

Metris S
31160000

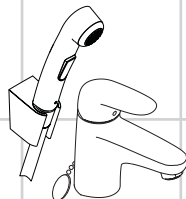

Metris E
31170000

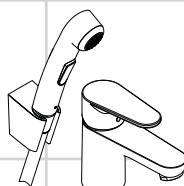

Talis E²
31165000

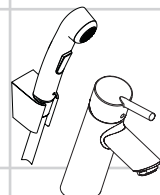

Talis S²
32140000

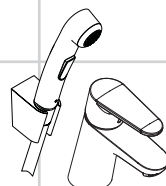

Focus
31926000

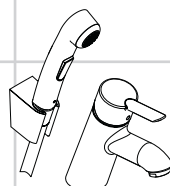

Focus S
37121000

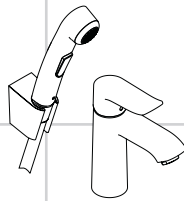

Metris
31285000

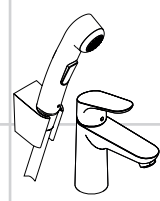

Focus 100
31927000



Sicherheitshinweise

- ⚠ Bei der Montage müssen zur Vermeidung von Quetsch- und Schnittverletzungen Handschuhe getragen werden.
- ⚠ Das Produkt darf nur zu Bade-, Hygiene- und Körperreinigungszwecken eingesetzt werden.
- ⚠ Große Druckunterschiede zwischen den Kalt- und Warmwasseranschlüssen müssen ausgeglichen werden.

Montagehinweise

- Vor der Montage muss das Produkt auf Transportschäden untersucht werden. Nach dem Einbau werden keine Transport- oder Oberflächenschäden anerkannt.
- Die Leitungen und die Armatur müssen nach den gültigen Normen montiert, gespült und geprüft werden.
- Die in den Ländern jeweils gültigen Installationsrichtlinien sind einzuhalten.
- Die Armatur kann nicht in Verbindung mit einem Durchlauferhitzer verwendet werden.

Technische Daten

Betriebsdruck:	max. 1 MPa
Empfohlener Betriebsdruck:	0,1 - 0,5 MPa
Prüfdruck:	1,6 MPa
(1 MPa = 10 bar = 147 PSI)	
Heißwassertemperatur:	max. 70 °C
Empfohlene Heißwassertemperatur:	65 °C
Thermische Desinfektion:	max. 70 °C / 4 min

Das Produkt ist ausschließlich für Trinkwasser konzipiert!

Symbolerklärung



Kein essigsäurehaltiges Silikon verwenden!



Justierung (siehe Seite)

Warmwasserbegrenzung einstellen



Maße (siehe Seite 36)



Durchflussdiagramm

(siehe Seite 38)

- ① Durchflussleistung Mischer
- ② Durchflussleistung Handbrause 1B



Bedienung (siehe Seite 35)

Aufgrund der Bauart der Bidette-Armatur, tritt während des Betriebs der Handbrause geringfügig Wasser am Auslauf der Armatur aus.

Hansgrohe empfiehlt, morgens oder nach längeren Stagnationszeiten den ersten halben Liter nicht als Trinkwasser zu verwenden.



Reinigung

siehe beiliegende Broschüre.



Serviceteile (siehe Seite 39)



Sonderzubehör (nicht im Lieferumfang enthalten)

Dichtung #98996000





Prüfzeichen (siehe Seite 44)



Montage siehe Seite 31



Consignes de sécurité

-  Lors du montage, porter des gants de protection pour éviter toute blessure par écrasement ou coupure.
-  Le système de douche ne doit servir qu'à se laver et à assurer l'hygiène corporelle.
-  Il est conseillé d'équilibrer les pressions de l'eau chaude et froide.

Instructions pour le montage

- Avant son montage, s'assurer que le produit n'a subi aucun dommage pendant le transport. Après le montage, tout dommage de transport ou de surface ne pourra pas être reconnu.
- Les conduites et la robinetterie doivent être montés, rincés et contrôlés selon les normes en vigueur.
- Les directives d'installation en vigueur dans le pays concerné doivent être respectées.
- Le robinet ne fonctionne pas avec une production d'eau chaude instantanée.

Informations techniques

Pression de service autorisée:	max. 1 MPa
Pression de service conseillée:	0,1 - 0,5 MPa
Pression maximum de contrôle: (1 MPa = 10 bar = 147 PSI)	1,6 MPa
Température d'eau chaude:	max. 70 °C
Température recommandée:	65 °C
Désinfection thermique:	max. 70 °C / 4 min

Le produit est exclusivement conçu pour de l'eau potable!

Description du symbole



Ne pas utiliser de silicone contenant de l'acide acétique!



Étalonnage (voir pages)

Positionner le limiteur de température



Dimensions (voir pages 36)



Diagramme du débit

(voir pages 38)

- ① Débit du mélangeur
- ② Débit douchette 1B



Instructions de service (voir pages 35)

La construction de la robinetterie Bidette fait qu'une légère quantité d'eau s'écoule au niveau de la sortie de la robinetterie, lors du fonctionnement de la douchette.

Hansgrohe recommande de ne pas utiliser le premier demi-litre le matin ou après une période de stagnation prolongée.



Nettoyage

voir la brochure ci-jointe.



Pièces détachées (voir pages 39)



Accessoires en option (ne fait pas partie de la fourniture)

joint #98996000



Classification acoustique et débit (voir pages 44)



Montage voir pages 31



Safety Notes

- ⚠️ Gloves should be worn during installation to prevent crushing and cutting injuries.
- ⚠️ The shower system may only be used for bathing, hygienic and body cleaning purposes.
- ⚠️ The hot and cold supplies must be of equal pressures.

Installation Instructions

- Prior to installation, inspect the product for transport damages. After it has been installed, no transport or surface damage will be honoured.
- The pipes and the fixture must be installed, flushed and tested as per the applicable standards.
- The plumbing codes applicable in the respective countries must be observed.
- The mixer can not used together with a continuous flow water heater.

Technical Data

Operating pressure:	max. 1 MPa
Recommended operating pressure:	0,1 - 0,5 MPa
Test pressure:	1,6 MPa
(1 MPa = 10 bar = 147 PSI)	
Hot water temperature:	max. 70 °C
Recommended hot water temp.:	65 °C
Thermal disinfection:	max. 70 °C / 4 min

The product is exclusively designed for drinking water!

Symbol description



Do not use silicone containing acetic acid!



Adjustment (see page)

Set hot water limiter



Dimensions (see page 36)



Flow diagram

(see page 38)

- ① Rate of flow mixer
- ② Rate of flow handshower 1B



Operation (see page 35)

Due to the design of the Bidette fittings, a small amount of water will leak at the outlet of the fitting when the hand shower is running.

Hansgrohe recommends not to use as drinking water the first half liter of water drawn in the morning or after a prolonged period of non-use.



Cleaning

see enclosed brochure.



Spare parts (see page 39)



Special accessories (order as an extra)

seal #98996000





Test certificate (see page 44)



Assembly see page 31



Indicazioni sulla sicurezza

-  Durante il montaggio, per evitare ferite da schiacciamento e da taglio bisogna indossare guanti protettivi.
-  Il sistema doccia deve essere utilizzato esclusivamente per l'igiene del corpo.
-  Attenzione! Compensare le differenze di pressione tra i collegamenti dell'acqua fredda e dell'acqua calda.

Istruzioni per il montaggio

- Prima del montaggio è necessario controllare che non ci siano stati danni durante il trasporto. Una volta eseguito il montaggio, non verranno riconosciuti eventuali danni di trasporto o delle superfici.
- Montare, lavare e controllare tubature e rubinetteria rispettando le norme correnti.
- Vanno rispettate le direttive di installazione nazionali vigenti nel rispettivo paese.
- Il rubinetto non può essere utilizzato insieme ad uno scaldacqua istantaneo.

Dati tecnici

Pressione d'uso:	max. 1 MPa
Pressione d'uso consigliata:	0,1 - 0,5 MPa
Pressione di prova:	1,6 MPa
(1 MPa = 10 bar = 147 PSI)	
Temperatura dell'acqua calda:	max. 70°C
Temp. dell'acqua calda consigliata:	65°C
Disinfezione termica:	max. 70°C / 4 min

Il prodotto è concepito esclusivamente per acqua potabile!

Descrizione simbolo



Non utilizzare silicone contenente acido acetico!



Taratura (vedi pagg.)

Regolare la limitazione dell'acqua calda



Ingombri (vedi pagg. 36)



Diagramma flusso

(vedi pagg. 38)

- ① Potenza di erogazione del miscelatore
- ② Potenza di erogazione docetta 1B



Procedura (vedi pagg. 35)

Dovuto dal tipo costruttivo del rubinetto Bidette, durante il funzionamento della doccia manuale dall'uscita del rubinetto fuoriesce minimamente dell'acqua.

Hansgrohe raccomanda, di mattina oppure dopo lunghi tempi di stagnazione, di non utilizzare il primo mezzo litro come acqua potabile.



Pulitura

vedi il prospetto accluso.



Parti di ricambio (vedi pagg. 39)



Accessori speciali (non contenuto nel volume di fornitura)

guarnizione #98996000



Segno di verifica (vedi pagg. 44)



Montaggio vedi pagg. 31



Indicaciones de seguridad

- ⚠ Durante el montaje deben utilizarse guantes para evitar heridas por aplastamiento o corte.
- ⚠ La grifería solo debe ser utilizada para fines de baño, higiene y limpieza corporal.
- ⚠ Grandes diferencias de presión en servicio entre agua fría y agua caliente deben equilibrarse.

Indicaciones para el montaje

- Antes del montaje se debe examinarse el producto contra daños de transporte. Después de la instalación so se reconoce ningún daño de transporte o de superficie.
- Los conductos y la grifería deben montarse, lavarse y comprobarse según las normas vigentes.
- Es obligatorio el cumplimiento de las directrices de instalación vigentes en el país respectivo.
- Este grifo no es apto en combinación con un calentador continuo.

Datos técnicos

Presión en servicio:	max. 1 MPa
Presión recomendada en servicio:	0,1 - 0,5 MPa
Presión de prueba:	1,6 MPa
(1 MPa = 10 bar = 147 PSI)	
Temperatura del agua caliente:	max. 70 °C
Temp. recomendada del agua caliente:	65 °C
Desinfección térmica:	max. 70 °C / 4 min

El producto ha sido concebido exclusivamente para agua potable.

Descripción de símbolos



No utilizar silicona que contiene ácido acético!



Ajuste (ver página)

ajustar tope



Dimensiones (ver página 36)



Diagrama de circulación

(ver página 38)

- ① Caudal mezclador
- ② Caudal máximo Teleducha 1B



Manejo (ver página 35)

Por el tipo de construcción del grifo del bidet, cuando se utiliza la ducha de mano sale menos agua por el grifo.

Hansgrohe recomienda no utilizar el primer medio litro como agua potable por las mañanas o tras un largo periodo de inactividad.



Limpiar

ver el folleto adjunto.



Repuestos (ver página 39)



Opcional (no incluido en el suministro)

Junta #98996000





Marca de verificación (ver página 44)



Montaje ver página 31



Veiligheidsinstructies

-  Bij de montage moeten ter voorkoming van knel- en snijwonden handschoenen worden gedragen.
-  Het douchesysteem mag alleen voor het wassen, hygiënische doeleinden en voor de lichaamreiniging worden gebruikt.
-  Grote drukverschillen tussen de koud- en warmwater-toevoer dienen vermeden te worden.

Montage-instructies

- Vóór de montage moet het product gecontroleerd worden op transportschade. Na de inbouw wordt geen transport- of oppervlakteschade meer aanvaard.
- De leidingen en armaturen moeten gemonteerd, gespoeld en gecontroleerd worden volgens de geldige normen.
- De in de overeenkomstige landen geldende installatie-richtlijnen moeten nageleefd worden.
- Het artikel kan niet in combinatie met een doorstroomtoestel toegepast worden.

Technische gegevens

Werkdruk: max.	max. 1 MPa
Aanbevolen werkdruk:	0,1 - 0,5 MPa
Getest bij:	1,6 MPa
(1 MPa = 10 bar = 147 PSI)	
Temperatuur warm water:	max. 70 °C
Aanbevolen warm water temp.:	65 °C
Thermische desinfectie:	max. 70 °C / 4 min

Het product is uitsluitend ontworpen voor drinkwater!

Symboolbeschrijving



Gebruik geen zuurhoudende silicone!



Instellen (zie blz.)

Heetwaterbegrenzer instellen



Maten (zie blz. 36)



Doorstroomdiagram

(zie blz. 38)

- ① Doorstroomcapaciteit mengkraan
- ② Doorstroomcapaciteit handdouche 1B



Bediening (zie blz. 35)

Vanwege de bouwwijze van de bidet-armatuur komt er tijdens de werking van de handdouche iets water uit de uitloop van de armatuur vrij.

Hansgrohe raadt aan om 's morgens na langere stagnatietijden de eerste halve liter niet als drinkwater te gebruiken.



Reinigen

zie bijgevoegde brochure.



Service onderdelen (zie blz. 39)



Toebehoren (behoort niet tot het leveringspakket)

dichting #98996000



Keurmerk (zie blz. 44)



Montage zie blz. 31



Sikkerhedsanvisninger

- △ Ved monteringen skal der bruges handsker for at undgå kvæstelser og snitsår.
- △ Brusersystemet må kun bruges til bade-, hygiejne og rengøringsformål.
- △ Større trykforskelle mellem koldt og varmt vand bør udjævnes.

Monteringsanvisninger

- Før monteringen skal produktet kontrolleres for transportskader. Efter monteringen godkendes transportskader eller skader på overfladen ikke længere.
- Ledningerne og armaturerne skal monteres, skylles og kontrolleres iht. de gældende standarder.
- Installationsbestemmelserne, der gælder i det enkelte land, skal overholdes.
- Armaturet bør ikke anvendes i forbindelse med en gennemstrømningsvandvarmer.

Tekniske data

Driftstryk:	max. 1 MPa
Anbefalet driftstryk:	0,1 - 0,5 MPa
Prøvetryk:	1,6 MPa
(1 MPa = 10 bar = 147 PSI)	
Varmtvandstemperatur:	max. 70 °C
Anbefalet varmtvandstemperatur:	65 °C
Termisk desinfektion:	max. 70 °C / 4 min

Produktet er udelukkende beregnet til drikkevand!

Symbolbeskrivelse



Der må ikke benyttes eddikesyreholdig silikone!



Forindstilling (se s.)

Indstil varmtvandsbe-grænsningen



Målene (se s. 36)



Gennemstrømningsdiagram

(se s. 38)

- ① Gennemstrømningskapacitet etgrebsarmaturer
- ② Gennemstrømningskap. håndbruser 1B



Brugsanvisning (se s. 35)

Pga. Bidette-armaturets byggemåde, træder en ringe mængde vand ud af armaturets afløb under håndbruserens drift.

Hansgrohe anbefaler at den første halve liter om morgenen eller efter længere stagneringstider ikke anvendes som drikkevand.



Rengøring

se venligst den vedlagte brochure.



Reserve dele (se s. 39)



Specialtilbehør (ikke med i leveringsomfang)

Pakning #98996000





Godkendelse (se s. 44)





Avisos de segurança

-  Durante a montagem devem ser utilizadas luvas de protecção, de modo a evitar ferimentos resultantes de entalamentos e de cortes.
-  O sistema de duche só pode ser utilizado para fins de higiene pessoal.
-  Grandes diferenças entre as pressões das águas quente e fria devem ser compensadas.

Avisos de montagem

- Antes da montagem deve-se controlar o produto relativamente a danos de transporte. Após a montagem não são aceites quaisquer danos de transporte ou de superfície.
- As tubagens e a torneira têm que ser montadas, enxaguadas e verificadas de acordo com as normas em vigor.
- A prescrições de instalação válidas nos respetivos países devem ser respeitadas.
- A misturadora não pode ser utilizada com esquentadores instantâneos ou caldeira.

Dados Técnicos

Pressão de funcionamento:	max. 1 MPa
Pressão de func. recomendada:	0,1 - 0,5 MPa
Pressão testada:	1,6 MPa
(1 MPa = 10 bar = 147 PSI)	
Temperatura da água quente:	max. 70°C
Temp. água quente recomendada:	65°C
Desinfecção térmica:	max. 70°C / 4 min

Este produto foi única e exclusivamente concebido para água potável!

Descrição do símbolo



Não utilizar silicone que contenha ácido acético!



Afinação (ver página)

Regular o limitador de temperatura



Medidas (ver página 36)



Fluxograma

(ver página 38)

- ① Caudal misturadora
- ② Caudal chuveiro de mão 1B



Funcionamento (ver página 35)

Devido ao tipo de construção da misturadora Bidette existe algum fluxo de água na saída da misturadora durante a utilização do chuveiro de mão.

A Hansgrohe recomenda a não utilização do primeiro meio litro de água, de manhã ou após longas paragens, para fins de consumo.



Limpeza

consultar a seguinte brochura.



Peças de substituição (ver página 39)



Acessórios especiais (não incluído no volume de fornecimento)

Vedante #98996000



Marca de controlo (ver página 44)





Wskazówki bezpieczeństwa

- ⚠ Aby uniknąć zranień, takich jak zgniecenia czy przecięcia, podczas montażu należy nosić rękawice.
- ⚠ Pysznica może być używany tylko do kąpieli, higieny i czyszczenia ciała.
- ⚠ Znaczne różnice ciśnień na dopływach ciepłej i zimnej wody muszą zostać wyrównane.

Wskazówki montażowe

- Przed montażem należy skontrolować produkt pod kątem szkód transportowych. Po montażu nie widać żadnych szkód transportowych ani szkód na powierzchni.
- Przewody i armatura muszą być montowane, płukane i kontrolowane według obowiązujących norm.
- Należy przestrzegać wytycznych instalacyjnych obowiązujących w danym kraju.
- Armatura nie może współpracować z przepływowymi podgrzewaczami wody.

Dane techniczne

Ciśnienie robocze:	maks. 1 MPa
Zalecane ciśnienie robocze:	0,1 - 0,5 MPa
Ciśnienie próbne:	1,6 MPa
(1 MPa = 10 bary = 147 PSI)	
Temperatura wody gorącej:	maks. 70 °C
Zalecana temperatura wody gorącej:	65 °C
Dezynfekcja termiczna:	maks. 70 °C / 4 min

Produkt przeznaczony wyłącznie do wody pitnej!

Opis symbolu



Nie stosować silikonów zawierających kwas octowy!



Ustawianie (patrz strona)

Ustawić ogranicznik ciepłej wody



Wymiary (patrz strona 36)



Schemat przepływu

(patrz strona 38)

- ① Wydajność przepływu przez mieszacz
- ② Wydajność przepływu przez prysznic ręczny 1B



Obsługa (patrz strona 35)

Ze względu na rodzaj konstrukcji armatury bidetu, w trakcie eksploatacji prysznic ręcznego wydostaje się na wylocie armatury niewielka ilość wody.

Hansgrohe zaleca, by z rana lub po dłuższym czasie niekorzystania, pierwsze pół litra wody nie używać jako wody pitnej.



Czyszczenie

patrz dołączona broszura.



Części serwisowe (patrz strona 39)



Wyposażenie specjalne (Nie jest częścią dostawy)

Uszczelka #98996000



Znak jakości (patrz strona 44)



Montaż patrz strona 31



Bezpečnostní pokyny

- △ Pro zabránění řezným zraněním a pohmožděninám je nutné při montáži nosit rukavice.
- △ Produkt smí být používán pouze ke koupání a za účelem tělesné hygieny.
- △ Je nutné vyrovnat velké rozdíly tlaku mezi přípoji studené a teplé vody.

Pokyny k montáži

- Před montáží je třeba produkt zkontrolovat, zda nebyl při transportu poškozen. Po zabudování nebudou uznány žádné škody způsobené transportem nebo poškození povrchu.
- Vedení a armatura musí být namontovány, propláchnuty a otestovány podle platných norem.
- Je třeba dodržovat montážní pravidla platná v dané zemi.
- Armatura se nesmí používat v kombinaci s průtokovým ohřívačem.

Technické údaje

Provozní tlak:	max. 1 MPa
Doporučený provozní tlak:	0,1 - 0,5 MPa
Zkušební tlak:	1,6 MPa
(1 MPa = 10 bar = 147 PSI)	
Teplota horké vody:	max. 70 °C
Doporučená teplota horké vody:	65 °C
Tepelná desinfekce:	max. 70 °C / 4 min

Výrobky Hansgrohe jsou vhodné pro přímý kontakt s pitnou vodou.

Popis symbolů



Nepoužívat silikon s obsahem kyseliny octové!



Nastavení (viz strana)

Seřadit zarážku pro teplou vodu



Rozměry (viz strana 36)



Diagram průtoku

(viz strana 38)

- ① Průtokové množství baterie
- ② Průtokové množství ruční sprchy 1B



Ovládání (viz strana 35)

Z důvodu typu konstrukce bidetové armatury, dochází během provozu ruční sprchy k drobnému vytékání vody na vývodu armatury.

Hansgrohe doporučuje ráno nebo po delších přestávkách nepoužívat prvního půl litru jako pitnou vodu.



Čištění

viz přiložená brožura.



Servisní díly (viz strana 39)



Zvláštní příslušenství (není součástí dodávky)

těsnění #98996000



Zkušební značka (viz strana 44)





Bezpečnostné pokyny

- ⚠ Pri montáži musíte nosiť rukavice, aby ste predišli pomliaždeninám a rezným poraneniam.
- ⚠ Produkt sa smie používať len na kúpanie a telesnú hygienu.
- ⚠ Veľké rozdiely v tlaku medzi prípojkami studenej a teplej vody musia byť vyrovnané.

Pokyny pre montáž

- Pred montážou musíte produkt skontrolovať, či nebol počas transportu poškodený. Po zabudovaní nebudú uznané žiadne škody spôsobené transportom alebo poškodenia povrchu.
- Ledningarna och blandaren måste monteras, spolás igenom och kontrolleras enligt de gällande normerna.
- Je potrebné dodržiavať smernice o inštalácii, ktoré sú práve teraz platné v krajinách.
- Armatúra sa nesmie používať v kombinácii s prietokovým ohrievačom.

Technické údaje

Prevádzkový tlak:	max. 1 MPa
Doporučený prevádzkový tlak:	0,1 - 0,5 MPa
Skúšobný tlak:	1,6 MPa
(1 MPa = 10 bar = 147 PSI)	
Teplota teplej vody:	max. 70 °C
Doporučená teplota teplej vody:	65 °C
Termická dezinfekcia:	max. 70 °C / 4 min

Výrobok je koncipovaný výhradne pre pitnú vodu!

Popis symbolov



Nepoužívať silikón s obsahom kyseliny octovej!



Nastavenie (viď strana)

Nastavenie zarážky na teplú vodu



Rozmery (viď strana 36)



Diagram prietoku

(viď strana 38)

- ① Prietokové množstvo zmiešavacej batérie
- ② Prietokové množstvo ručnej sprchy 1B



Obsluha (viď strana 35)

Z dôvodu konštrukcie bidetovej armatúry uniká počas prevádzky ručnej sprchy nepatrné množstvo vody z výstupu armatúry.

Hansgrohe odporúča ráno a po dlhších dobách odstavky nepoužiť prvého pol litra vody ako pitnú vodu.



Čistenie

nájdete v priloženej brožúre.



Servisné diely (viď strana 39)



Zvláštne príslušenstvo (nie je súčasťou dodávky)

tesnenie #98996000



Osvedčenie o skúške (viď strana 44)





⚠️ 安全技巧

- △ 装配时为避免挤压和切割受伤，必须戴上手套。
- △ 淋浴系统只允许作为洗浴、卫生和洁身之用。
- △ 冷热水管间过大的压力差必须予以平衡。

安装提示

- 安装前必须检查产品是否受到运输损害。安装后将不认可运输损害或表面损伤。
- 管道和阀门必须根据通用标准进行安装、冲洗和检查。
- 请遵守当地国家现行的安装规定。
- 阀门不可与即热式热水器连接使用。

技术参数

工作压强:	最大 1 MPa
推荐工作压强:	0,1 – 0,5 MPa
测试压强:	1,6 MPa
(1 MPa = 10 bar = 147 PSI)	
热水温度:	最大 70°C
推荐热水温度:	65°C
热力消毒:	最大 70°C / 4 分钟

该产品专为饮用水设计！

符号说明



请勿使用含有乙酸的硅！



调节 (参见第页)

设置热水控制器



大小 (参见第页 36)



流量示意图
(参见第页 38)

- ① 龙头流速
- ② 手提花洒流速 1B



操作 (参见第页 35)

由于坐浴龙头的结构形式，使用手持花洒时龙头出水口溢出少许水。

汉斯格雅建议，清晨或在水流长时间停滞，前半升水不作饮用水使用。



清洗

附有小手册



备用零件 (参见第页 39)



选装附件 (不在供货范围内)

垫圈 #98996000





检验标记 (参见第页 44)



安装 参见第页 31



Указания по технике безопасности

-  Во время монтажа следует надеть перчатки во избежание прищемления и порезов.
-  Изделие разрешается использовать только в гигиенических целях: для принятия ванны и личной гигиены.
-  донного клапа. Перед установкой смесителя необходимо регулировочными кранами выровнять давление холодной и горячей воды при помощи вентилей регулирующих подачу воды в квартиру.

Указания по монтажу

- Перед монтажом следует проверить изделие на предмет повреждений при перевозке. После монтажа претензии о возмещении ущерба за повреждения при перевозке или повреждения поверхностей не принимаются.
- Трубы и арматура должны быть установлены, промыты и проверены в соответствии с действующими нормами.
- Необходимо соблюдать требования по монтажу, действующие в соответствующих странах.
- Применение арматуры при наличии проточного нагревателя не допускается.

Технические данные

Рабочее давление:	не более. 1 МПа
Рекомендуемое рабочее давление:	0,1 - 0,5 МПа
Давление:	1,6 МПа
(1 МПа = 10 bar = 147 PSI)	
Температура горячей воды:	не более. 70 °С
Рекомендуемая темп. гор. воды:	65 °С
Термическая дезинфекция:	не более. 70 °С / 4 мин

Изделие предназначено исключительно для питьевой воды!

Описание символов



Не применяйте силикон, содержащий искусственную кислоту.



Подгонка (см. стр.)

Отрегулируйте ограничение горячей воды



Измерения (см. стр. 36)



Схема потока

(см. стр. 38)

- ① Пропускная способность смесителя
- ② Пропускная способность ручного душа 1В



Эксплуатация (см. стр. 35)

В силу строения арматуры биде в процессе работы ручного душа через выпускное отверстие арматуры выходит небольшое количество воды.

Hansgrohe рекомендует по утрам либо после длительного перерыва в использовании не использовать первые поллитра воды для питья.



Очистка

см прилагаемая брошюра



Комплект (см. стр. 39)



Специальные принадлежности (не включено в объем поставки!)

Уплотнение #98996000



Значение технического контроля
(см. стр. 44)





Biztonsági utasítások

- ⚠ A szerelésnél a zúzódások és vágási sérülések elkerülése érdekében kesztyűt kell viselni.
- ⚠ A terméket csak fürdéshez, mosakodáshoz, és egészségügyi tisztálkodáshoz szabad használni.
- ⚠ A hidegvíz- és melegvíz-csatlakozások közötti nagy nyomáskülönbséget kikell egyenlíteni!

Szerelési utasítások

- A szerelés előtt ellenőrizni kell, hogy a terméknek nincs-e szállítási sérülése. Beépítés után a szállítási-vagy felületi sérüléseket nem ismerik el.
- A vezetékeket és a csaptelepet az érvényes szabványoknak megfelelően kell felszerelni, öblíteni és ellenőrizni
- Az egyes országokban érvényes installációs irányelveket be kell tartani.
- A vízcsapot nem lehet átfolyós vízmelegítővel használni.

Műszaki adatok

Üzemi nyomás:	max. 1 MPa
Ajánlott üzemi nyomás:	0,1 - 0,5 MPa
Nyomáspróba: (1 MPa = 10 bar = 147 PSI)	1,6 MPa
Forróvíz hőmérséklet:	max. 70 °C
Forróvíz javasolt hőmérséklete:	65 °C
Termikus fertőtlenítés:	max. 70 °C / 4 perc

A terméket kizárólag ivóvízhez tervezték!

Szimbólumok leírása



Ne használjon ecetsavtartalmú szilikon!



Beállítás (lásd a oldalon)

A melegvíz szabályozót újra be kell állítani.



Méretet (lásd a oldalon 36)



Átfolyási diagramm

(lásd a oldalon 38)

- ① Átfolyási teljesítmény, keverő
- ② Átfolyási teljesítmény, kézi zuhany 1B



Használat (lásd a oldalon 35)

A bidette csaptelepének felépítése miatt, a kézi zuhany üzemeltetése alatt nyhe mértékben víz léphet ki a csaptelepből.

A Hansgrohe azt ajánlja, hogy hosszabb állási idő után az első fél liter vizet ne használja ivóvízként.



Tisztítás

lásd a mellékelt brosúrát.



Tartozékok (lásd a oldalon 39)



Egyéb tartozék (a szállítási egység nem tartalmazza)

Tömítés #98996000



Vizsgajel (lásd a oldalon 44)



Szerelés lásd a oldalon 31



Turvallisuushjeet

- △ Asennuksessa on käytettävä käsiineitä puristumien ja viiltojen aiheuttamien tapaturmien estämiseksi.
- △ Suihkujärjestelmää saa käyttää ainoastaan kylpy-, hygienia- ja puhdistustarkoituksiin.
- △ Suuret paine-erot kylmä- ja kuumavesiliitännöiden välillä on tasattava.

Asennusohjeet

- Ennen asennusta on tarkastettava tuotteen mahdolliset kuljetusvahingot. Asennuksen jälkeen kuljetus- ja pintavaurioita ei hyväksytä.
- Putket ja hana on asennettava, huuhdeltava ja tarkastettava voimassa olevien standardien mukaisesti.
- Jokaisessa maassa on noudatettava siellä päteviä asennusohjeita.
- Armaturia ei voi käyttää läpimenvedenkuumentimen yhteydessä.

Tekniset tiedot

Käyttöpaine:	maks. 1 MPa
Suosittelut käyttöpaine:	0,1 - 0,5 MPa
Koestuspaine:	1,6 MPa
(1 MPa = 10 bar = 147 PSI)	
Kuuman veden lämpötila:	maks. 70 °C
Kuuman veden suosituslämpötila:	65 °C
Lämpödesinfektio:	maks. 70 °C / 4 min

Tuote on suunniteltu käytettäväksi ainoastaan juomaveden kanssa!

Merkin kuvaus



Älä käytä etikkahappopitoista silikonia!



Säätö (katso sivu)

Säädä lämmiaveden rajoitin



Mitat (katso sivu 36)



Virtausdiagrammi

(katso sivu 38)

- ① Sekoittimen läpivirtausmäärä
- ② Käsisuihkun läpivirtausmäärä 1 B



Käyttö (katso sivu 35)

Bideesuihku on rakenteeltaan sellainen, että suihkua käytettäessä hanasta valuu hieman vettä.

Hansgrohe suosittelee, että ensimmäistä puolta litraa ei käytetä juomavetenä aamuisin eikä silloin, kun laitetta ei ole käytetty pitkään aikaan.



Puhdistus

katso oheinen esite



Varaosat (katso sivu 39)



Eriyisvaruste (ei kuulu toimitukseen)

Tiiviste #98996000



Koestusmerkki (katso sivu 44)





Säkerhetsanvisningar

- △ Handskar ska bäras under monteringsarbetet så att man kan undvika kläm- och skärskador gen. werden.
- △ Produkten får bara användas till kroppshygien med bad och dusch.
- △ Stora tryckskillnader mellan anslutningarna för varmt och kallt vatten måste utjämnas.

Monteringsanvisningar

- Det måste undersökas om produkten har transportskador innan den monteras. Efter monteringen accepteras inga transport- eller ytskiktsskador.
- Ledningarna och blandaren måste monteras, spolas igenom och kontrolleras enligt de gällande normerna.
- De installationsriktlinjer som gäller i länderna ska följas.
- Blandaren kan inte användas tillsammans med en varmvattenberedare.

Tekniska data

Driftstryck:	max. 1 MPa
Rek. driftstryck:	0,1 - 0,5 MPa
Tryck vid provtryckning: (1 MPa = 10 bar = 147 PSI)	1,6 MPa
Varmvattentemperatur:	max. 70 °C
Rek. varmvattentemp.:	65 °C
Termisk desinfektion:	max. 70 °C / 4 min

Produkten är enbart avsedd för dricksvatten!

Symbolförklaring



Använd inte silikon som innehåller ättiksyra!



Justering (se sidan)

Ställ in varmvattenreglering



Måtten (se sidan 36)



Flödesschema

(se sidan 38)

- ① Genomströmningkapacitet ettgrepps-blandare
- ② Genomströmningkapacitet handdusch 1B



Hantering (se sidan 35)

Bidette-blandarens konstruktion gör att det rinner ut lite vatten ur blandaren medan handduschen används.

Hansgrohe rekommenderar att den första halvlitern inte används som dricksvatten på morgonen eller efter längre perioder utan användning.



Rengöring

se den medföljande broschyren



Reservdelar (se sidan 39)



Specialtillbehör (medföljer ej leveransen)

Packning #98996000



Testsigill (se sidan 44)





Saugumo technikos nurodymai

- ⚠ Apsaugai nuo užspaudimo ir įsipijavimo montavimo metu mūvėkite pirštines.
- ⚠ Gaminys turi būti naudojamas tik maudymuisi, kūno higienai ir švarai palaikyti.
- ⚠ Turi būti išlyginti šalto ir karšto slėgio nelygumai.

Montavimo instrukcija

- Prieš montuojant būtina patikrinti, ar gaminys nebuvo pažeistas transportavimo metu. Sumontavus pretenzijos dėl transportavimo ir paviršiaus pažeidimų nepriimamos.
- Vamzdžiai ir sujungimai turi būti montuojami, plaunami ir tikrinami pagal galiojančias normas.
- Laikykitės atitinkamoje šalyje galiojančių direktyvų dėl įrengimo.
- Armatūros negalima naudoti kartu su tekančio vandens šildytuvu.

Techniniai duomenys

Darbinis slėgis: ne daugiau kaip 1 MPa
 Rekomenduojamas slėgis: 0,1 - 0,5 MPa
 Bandomasis slėgis: 1,6 MPa
 (1 MPa = 10 barų = 147 PSI)
 Karšto vandens temperatūra: ne daugiau kaip 70 °C
 Rekomenduojama karšto vandens temperatūra: 65 °C
 Terminis dezinfekavimas: ne daugiau kaip 70 °C / 4 min

Produktas skirtas tik geriamajam vandeniui!

Simbolio aprašymas



Nenaudokite silikono, kurio sudėtyje yra acto rūgšties!



Reguliavimas

 (žr. psl.)

Nustatyti karšto vandens ribotuvą



Išmatavimai

 (žr. psl. 36)

Pralaidumo diagrama

(žr. psl. 38)

- ① Vandens pralaidumas. Maišytuvus
- ② Rankų dušo vandens pralaidumas 1B



Eksplotacija

 (žr. psl. 35)

Dėl bidetė dušelio konstrukcijos, naudojant rankinį dušelį, iš maišytuvo išteka nedaug vandens.

Naudojant po ilgesnės pertraukos, „Hansgrohe“ rekomenduoja pirmo pusės litro vandens nevertoti kaip geriamojo.



Valymas

žr. pridename brošiūroje.



Atsarginės dalys

 (žr. psl. 39)

Specialūs priedai

 (nėra pridama)

Tarpinė #98996000





Bandymo pažyma

 (žr. psl. 44)



Sigurnosne upute

-  Prilikom montaže se radi sprječavanja prignječenja i posjekotina moraju nositi rukavice.
-  Proizvod se smije primjenjivati samo za kupanje, tuširanje i osobnu higijenu.
-  Velika razlika u pritisku između vruće i hladne vode mora biti izbalansirana.

Upute za montažu

- Prije montaže mora se provjeriti je li proizvod oštećen prilikom transporta. Nakon ugradnje se ne priznaju nikakve reklamacije koje se odnose na površinska i transportna oštećenja.
- Cijevi i armatura moraju biti postavljeni, isprani i testirani prema važećim normama.
- Obvezno se moraju uvažiti propisi o instalacijama koji vrijede u dotičnoj zemlji.
- Armatura se ne može rabiti u kombinaciji sa protočnim bojlerom.

Tehnički podatci

Najveći dopušteni tlak:	tlak 1 MPa
Preporučeni tlak:	0,1 - 0,5 MPa
Probni tlak:	1,6 MPa
(1 MPa = 10 bar = 147 PSI)	
Temperatura vruće vode:	tlak 70 °C
Preporučena temperatura vruće vode:	65 °C
Termička dezinfekcija:	tlak 70 °C / 4 min

Proizvod je koncipiran isključivo za pitku vodu!

Opis simbola



Nemojte koristiti silikon koji sadrži octenu kiselinu!



Regulacija (pogledaj stranicu)

Podesite limiter vruće vode



Mjere (pogledaj stranicu 36)



Dijagram protoka

(pogledaj stranicu 38)

- ① Protok vode Slavina
- ② Protok vode Ručni tuš 1B



Upotreba (pogledaj stranicu 35)

Zbog konstrukcijske izvedbe armature bidea tijekom rada ručnog tuša na ispustu armature može izlaziti voda.

Hansgrohe preporuča da ujutro ili nakon duljeg nekorisćenja prvih 1/2 litre vode ne upotrebljavate za piće.



Čišćenje

se u priloženoj brošuri.



Rezervni djelovi (pogledaj stranicu 39)



Posebni pribor (Nije sadržano u isporuci!)

brtva #98996000



Oznaka testiranja (pogledaj stranicu 44)





⚠ Güvenlik uyarıları

- ⚠ Montaj esnasında ezilme ve kesilme gibi yaralanmaları önlemek için eldiven kullanılmalıdır.
- ⚠ Duş sistemi yalnızca banyo, hijyen ve beden temizliği amaçları doğrultusunda kullanılabilir.
- ⚠ Sıcak ve soğuk su bağlantıları arasında büyük basınç farklılıkları varsa, bu basınç farklılıklarının dengelenmesi gerekir.

Montaj açıklamaları

- Montaj işleminden önce ürün nakliye hasarları yönünden kontrol edilmelidir. Montaj işleminden sonra nakliye veya yüzey hasarları için sorumluluk üstlenilmemektedir.
- Boruların ve armatürün montajı, yıkanması ve kontrolü geçerli normlara göre yapılmalıdır.
- Ülkelerde geçerli kurulum yönetmeliklerine riayet edilmelidir.
- Armatür bir akış ısıtıcısı ile birlikte kullanılamaz.

Teknik bilgiler

İşletme basıncı:	azami 1 MPa
Tavsiye edilen işletme basıncı:	0,1 - 0,5 MPa
Kontrol basıncı:	1,6 MPa
(1 MPa = 10 bar = 147 PSI)	
Sıcak su sıcaklığı:	azami 70 °C
Tavsiye edilen su ısıtı:	65 °C
Termik dezenfeksiyon:	azami 70 °C / 4 dak

Ürün sadece şebeke suyu için tasarlanmıştır!

Simge açıklaması



Asetik asit içeren silikon kullanmayın!



Ayarlama (bakınız sayfa)

Isı limitleyiciyi yeniden ayarlayın



Ölçüleri (bakınız sayfa 36)



Akış diyagramı

(bakınız sayfa 38)

- ① Miks bataryanın debisi
- ② El duşunun debisi 1B



Kullanımı (bakınız sayfa 35)

Bidette armatürünün yapı türünden dolayı el duşunun çalışması sırasında armatürün çıkışından az miktarda su çıkar.

Hansgrohe sabahları uzun durgunluk süresi sonrasında ilk yarım litre suyun içme suyu olarak kullanılmamasını önerir.



Temizleme

birlikte verilen broşür



Yedek Parçalar (bakınız sayfa 39)



Özel aksesuarlar (Teslimat kapsamına dahil değildir)

Conta #98996000



Kontrol işareti (bakınız sayfa 44)





Instrucțiuni de siguranță

- ⚠ La montare utilizați mănuși pentru evitarea contuziunilor și tăierii mâinilor.
- ⚠ Sistemul de duș poate fi utilizat doar pentru spălarea, menținerea igienei și curățarea corpului.
- ⚠ Diferențele de presiune mari între alimentarea cu apă rece și apă caldă trebuie echilibrate.

Instrucțiuni de montare

- Înainte de instalare verificați, dacă produsul prezintă deteriorări de transport. După instalare garanția nu acoperă deteriorările de transport și cele de suprafață.
- Conductele și bateriile trebuie montate, spălate și verificate conform normelor în vigoare.
- Respectați reglementările referitoare la instalare valabile în țara respectivă.
- Bateria nu poate fi utilizată în combinație cu un boiler în flux continuu.

Date tehnice

Presiune de funcționare:	max. 1 MPa
Presiune de funcționare recomandată:	0,1 - 0,5 MPa
Presiune de verificare:	1,6 MPa
(1 MPa = 10 bar = 147 PSI)	
Temperatura apei calde:	max. 70 °C
Temperatura recomandată a apei calde:	65 °C
Dezinfecție termică:	max. 70 °C / 4 min

Produsul este destinat exclusiv pentru apă potabilă.

Descrierea simbolurilor



Nu utilizați silikon cu conținut de acid acetic!



Reglare (vezi pag.)

Setați limitarea temperaturii apei calde.



Dimensiuni (vezi pag. 36)



Diagrama de debit

(vezi pag. 38)

- ① Debitul de apă al bateriei
- ② Debitul de apă al dușului de mână 1B



Utilizare (vezi pag. 35)

Datorită construcției armăturii de bideu, în timpul utilizării dușului de mână, se poate scurge puțină apă la gura de scurgere a armăturii.

Hansgrohe vă recomandă, ca dimineața sau după perioade mai lungi de pauză să nu folosiți prima jumătate de litru de apă pentru băut.



Curățare

vezi broșura alăturată.



Piese de schimb (vezi pag. 39)



Accesorii opționale (nu este inclus în setul livrat)

Garnitură #98996000



Certificat de testare (vezi pag. 44)





⚠ Υπ δείξεις σφ λεί ς

- ⚠ Για να αποφύγετε τραυματισμούς κατά τη συναρμολόγηση πρέπει να φοράτε γάντια.
- ⚠ Το προϊόν επιτρέπεται να χρησιμοποιείται μόνο σαν μέσο λουτρού, υγιεινής και καθαρισμού του σώματος.
- ⚠ Οι διαφορές της πίεσης μεταξύ της σύνδεσης κρύου και ζεστού νερού θα πρέπει να αντισταθμίζονται.

Οδηγίες σ ν ρμ λόγησης

- Πριν τη συναρμολόγηση πρέπει να εξεταστεί το προϊόν για ζημιές μεταφοράς. Μετά την εγκατάσταση δεν αναγνωρίζονται ζημιές από τη μεταφορά ή επιφανειακές ζημιές.
- Οι σωλήνες και η μπαταρία πρέπει να τοποθετηθούν σύμφωνα με τα ισχύοντα πρότυπα, να τεθούν υπό πίεση και να δοκιμαστούν.
- Θα πρέπει να τηρούνται οι οδηγίες εγκατάστασης που ισχύουν σε κάθε κράτος.
- Η μπαταρία δεν μπορεί να χρησιμοποιηθεί σε συνδυασμό με ταχυθερμοσίφωνα.

Τεχνικά Χ ρ κτηριστικά

Λειτουργία πίεσης:	έως 1 MPa
Συνιστώμενη λειτουργία πίεσης:	0,1 - 0,5 MPa
Πίεση ελέγχου:	1,6 MPa
(1 MPa = 10 bar = 147 PSI)	
Θερμοκρασία ζεστού νερού:	έως 70°C
Συνιστώμενη θερμοκρασία ζεστού νερού:	65°C
Θερμική απολύμανση:	έως 70°C / 4 min

Το προϊόν έχει σχεδιαστεί αποκλειστικά για πόσιμο νερό!

Περιργ φή σ μβόλων



Μην χρησιμοποιείτε σιλικόνη που περιέχει οξικό οξύ!



Ρύθμιση (βλ. Σελίδα)

Ρυθμίστε την περιοριστική διάταξη του ζεστού νερού



Δι στάσεις (βλ. Σελίδα 36)



Διάργ μ μ ρ ής

(βλ. Σελίδα 38)

- ① Κατανάλωση νερού στην μπαταρία
- ② Κατανάλωση νερού σε καταιονιστήρα χειρός 1B



Χειρισμός (βλ. Σελίδα 35)

Λόγω της κατασκευής της μπαταρίας του μπιντέ μπορεί κατά τη διάρκεια της λειτουργίας του ντους να τρέξει λίγο νερό από το ρουζούνι της μπαταρίας.

Η Hansgrohe συνιστά το πρωί ή μετά από μεγάλα χρονικά διαστήματα αχρησίας να μην χρησιμοποιείτε το πρώτο μισό λίτρο νερό σαν πόσιμο.



Κ θ ρισμός

βλ. συνημμένο φυλλάδιο



Αντ λλ κτικά (βλ. Σελίδα 39)



Ειδικά ξεσ άρ (δεν περιλαμβάνεται στον παραδοτέο εξοπλισμό)

Παρέμβυσμα #98996000



Σήμ ελέγχ (βλ. Σελίδα 44)





Varnostna opozorila

- ⚠ Pri montaži je treba nositi rokavice, da se preprečijo poškodbe zaradi zmečkanja ali urezov.
- ⚠ Ta izdelek se sme uporabljati le z namenom umivanja, vzdrževanja higiene in telesne nege.
- ⚠ Velike razlike v tlaku med priključkom za mrzlo in priključkom za toplo vodo je potrebno izravnati.

Navodila za montažo

- Pred montažo je treba izdelek preveriti glede morebitnih transportnih poškodb. Po vgradnji transportne ali površinske poškodbe ne bodo več priznane.
- Cevi in armaturo je treba montirati, izprati in preveriti po veljavnih standardih.
- Upoštevati je treba pravilnike o inštalacijah, ki veljajo v posamezni državi.
- Armature ni možno uporabiti v povezavi s pretočnim grelnikom.

Tehnični podatki

Delovni tlak:	maks. 1 MPa
Priporočeni delovni tlak:	0,1 - 0,5 MPa
Preskusni tlak:	1,6 MPa
(1 MPa = 10 bar = 147 PSI)	
Temperatura tople vode:	maks. 70 °C
Priporočena temperatura tople vode:	65 °C
Termična dezinfekcija:	maks. 70 °C / 4 min

Proizvod je zasnovan izključno za sanitarno vodo!

Opis simbola



Ne smete uporabiti silikona, ki vsebuje očetno kislino!



Justiranje (glejte stran)

Nastavite omejevalnik tople vode



Mere (glejte stran 36)



Diagram pretoka

(glejte stran 38)

- ① Pretok vode mešalna baterija
- ② Pretok vode ročna prha 1B



Upravljanje (glejte stran 35)

Vsled konstrukcije armature za bidet iz nje med delovanjem ročne prhe izteka majhna količina vode.

Hansgrohe priporoča, da zjutraj ali po daljšem času stagnacije prvega pol litra vode ne uporabite kot pitno vodo.



Čiščenje

glejte priloženi brošuri.



Rezervni deli (glejte stran 39)



Poseben pribor (Ni vključeno)

Tesnilo #98996000



Preskusni znak (glejte stran 44)



Montaža glejte stran 31



⚠ Ohutusjuhised

- ⚠ Kandke paigaldamisel muljumis- ja löikevigastuste vältimiseks kindaid.
- ⚠ Toodet tohib kasutada ainult pesemis-, hügieeni- ja kehapihustamiseesmärkidel.
- ⚠ Kui külma ja kuumu vee ühenduste surve on väga erinev, tuleb need tasakaalustada.

Paigaldamisjuhised

- Enne paigaldamist tuleb toodet kontrollida transpordikahjustuste osas. Pärast paigaldamist ei tunnustata enam transpordi- või pinnakahjustuste kaebuseid.
- Voolikute ja segisti paigaldamisel, loputamisel ja kontrollimisel tuleb lähtuda kehtivatest normatiividest.
- Vastavas riigis kehtivaid paigalduseeskirju tuleb järgida.
- Segistit ei saa kasutada koos läbivoolu-veesoojendiga.

Tehnilised andmed

Töörõhk	maks. 1 MPa
Soovitavat töörõhk:	0,1 - 0,5 MPa
Kontrollsurve:	1,6 MPa
(1 MPa = 10 baari = 147 PSI)	
Kuumu vee temperatuur:	maks. 70 °C
Soovitavat kuumu vee temperatuur:	65 °C
Termiline desinfitatsioon:	maks. 70 °C / 4 min

Toode on ette nähtud eranditult joogivee jaoks!

Sümbolite kirjeldus



Ärge kasutage äädikhapet sisaldavat silikooni!



Reguleerimine (vt lk)

Seadke kuumu vee piirang



Mõõtude (vt lk 36)



Läbivooludiagramm

(vt lk 38)

- ① Segisti läbivool
- ② Käsiduši läbivool 1B



Kasutamine (vt lk 35)

Bidette-armatuuri konstruktsioonist tingituna tuleb käsiduši kasutamise ajal armatuuri väljavoolust vähesel määral vett.

Hansgrohe soovib mitte kasutada esimest poolt liitrit hommikuti või pärast pikemat seisakuaega joogiveena.



Puhastamine

vt kaasasolevast brošüürist.



Varuosad (vt lk 39)



Spetsiaalne lisavarustus (ei sisaldu komplektis)

tihend #98996000



Kontrollsertifikaat (vt lk 44)





Drošības norādes

- ⚠ Montāžas laikā, lai izvairītos no saspiedumiem un iegriezumiem, nepieciešams nēsāt cimdus.
- ⚠ Šo produktu drīkst izmantot tikai, lai mazgātos, higiēnai un ķermeņa tīrīšanai.
- ⚠ Jāizlīdzina spiediena atšķirības starp aukstā un karstā ūdens pievadiem.

Norādījumi montāžai

- Pirms montāžas nepieciešams pārbaudīt, vai produktam transportēšanas laikā nav radušies bojājumi. Pēc iebūvēšanas bojājumi, kas radušies transportēšanas laikā, vai virsmas bojājumi netiek atzīti.
- Caurulvadi un armatūra ir jāuzstāda, jāizskalo un jāpārbauda saskaņā ar spēkā esošajiem standartiem.
- Jāievēro attiecīgās valstīs spēkā esošās montāžas prasības.
- Armatūru nevar izmantot kopā ar caurplūdes sildītāju.

Tehniskie dati

Darba spiediens:	maks. 1 MPa
leteicamais darba spiediens:	0,1 - 0,5 MPa
Pārbaudes spiediens:	1,6 MPa
(1 MPa = 10 bar = 147 PSI)	
Karstā ūdens temperatūra:	maks. 70 °C
leteicamā karstā ūdens temperatūra:	65 °C
Termiskā dezinfekcija :	maks. 70 °C / 4 min

Izstrādājums ir paredzēts tikai dzeramajam ūdenim!

Simbolu nozīme



Neizmantojiet silikonu, kas satur etiķskābi!



Ieregulēšana (skat. lpp.)

Noregulēt karstā ūdens ierobežošanu



Izmērus (skat. lpp. 36)



Caurplūdes diagramma

(skat. lpp. 38)

- ① Caurteces intensitāte jaucējkrānam
- ② Caurteces intensitāte rokas dušai 1B



Lietošana (skat. lpp. 35)

Bidē armatūras konstrukcijas dēļ rokas dušas darba laikā no armatūras izplūdes atveres iznāk neliels ūdens daudzums.

Handgrohe iesaka no rīta vai pēc ilgākiem pārtraukumiem nelietot pirmo puslitru ūdens dzeršanai.



Tīrīšana

skatiet pievienotajā brošūrā.



Rezerves daļas (skat. lpp. 39)



Speciāli aksesuāri (komplektā netiek piegādāts)

Blive #98996000





Pārbaudes zīme (skat. lpp. 44)





Sigurnosne napomene

-  Prilikom montaže se radi sprečavanja prignječenja i posekotina moraju nositi rukavice.
-  Proizvod sme da se koristi samo za kupanje, tuširanje i ličnu higijenu.
-  Velika razlika u pritisku između vruće i hladne vode mora biti izbalansirana.

Instrukcije za montažu

- Pre montaže se mora proveriti da li je proizvod oštećen pri transportu. Nakon ugradnje se ne priznaju nikakve reklamacije koje se odnose na površinska i transportna oštećenja.
- Vodovi i armatura moraju biti postavljeni, isprani i testirani prema važećim normama.
- Treba se pridržavati propisa koji u određenim zemljama važe za instalacije.
- Armatura se ne može upotrebljavati u kombinaciji sa protočnim bojlerom.

Tehnički podaci

Radni pritisak:	maks. 1 MPa
Preporučeni radni pritisak:	0,1 - 0,5 MPa
Probni pritisak:	1,6 MPa
(1 MPa = 10 bar = 147 PSI)	
Temperatura vruće vode:	maks. 70 °C
Preporučena temperatura vruće vode:	65 °C
Termička dezinfekcija:	maks. 70 °C / 4 min

Proizvod je koncipiran isključivo za pijaću vodu!

Opis simbola



Nemojte koristiti silikon koji sadrži sirćetnu kiselinu!



Podešavanje (vidi stranu)

Podesite ograničavač vruće vode



Mere (vidi stranu 36)



Dijagram protoka

(vidi stranu 38)

- ① Protok vode mešač
- ② Protok vode ručni tuš 1B



Rukovanje (vidi stranu 35)

Uslovljeno konstrukcijom armature bidea, tokom rada ručnog tuša na slavini armature može izlaziti voda.

Hansgrohe preporučuje da ujutru ili nakon dužeg nekorišćenja prvih pola litre vode ne koristite za piće.



Čišćenje

vidi priloženoj brošuri.



Rezervni delovi (vidi stranu 39)



Poseban pribor (Nije sadržano u isporuci)

Zaptivka #98996000



Ispitni znak (vidi stranu 44)





Sikkerhetshenvisninger

- △ Bruk hansker under montasjen for å unngå klem- og kuttskader.
- △ Dusjsystemet skal kun brukes for bade-, hygiene- og kroppshygiene.
- △ Store trykkdifferanser mellom kaldt- og varmtvannstilkoblinger skal utlignes.

Montagehenvisninger

- Før montasjen skal produktet sjekkes for transportskader. Etter monteringen aksepteres ikke noen transport- eller overflateskader.
- Ledningene og armaturen skal monteres, spyles og sjekkes iht. de gyldige normer.
- Gjeldende retningslinjer for rørleggerarbeid i de enkelte land skal følges.
- Armaturen kan ikke brukes i forbindelse med en gjennomstrømningsvannvarmer.

Tekniske data

Driftstrykk	maks. 1 MPa
Anbefalt driftstrykk:	0,1 - 0,5 MPa
Prøvetrykk	1,6 MPa
(1 MPa = 10 bar = 147 PSI)	
Varmtvannstemperatur	maks. 70 °C
Anbefalt temperatur for varmt vann	65 °C
Termisk desinfisering:	maks. 70 °C / 4 min

Produktet er utelukkende designet for drikkevann!

Symbolbeskrivelse



Ikke bruk silikon som inneholder eddiksyre!



Justering (se side)

Varmtvannsbegrensning innstilles



Mål (se side 36)



Gjennomstrømningsdiagram

(se side 38)

- ① Gjennomstrømningsytelse blandedbatteri
- ② Gjennomstrømningsytelse hånddusj 1 B



Betjening (se side 35)

På grunn av Bidette-armaturens byggemåte, kan det renne litt vann ut fra utløpet under bruken av hånddusjen.

Om morgen og etter lengre stagnasjonstider anbefaler Hansgrohe å ikke bruke den første halvliteren som drikkevann.



Rengjøring

se vedlagt brosjyre.



Serviceleder (se side 39)



Ekstratilbehør (ikke med i leveransen)

Pakning #98996000



Prøvemerke (se side 44)





Ук з ния з безоп сност

- △ При монтажа трябва да се носят ръкавици, за да се избегнат наранявания поради притискане или порязване.
- △ Позволено е използването на продукта само за къпане, хигиена и цели на почистване на тялото.
- △ Големите разлики в налягането между изводите за студената и топлата вода трябва да се изравняват.

Ук з ния з монт ж

- Преди монтажа продуктът трябва да се провери за транспортни щети. След монтажа не се признават транспортни или повърхностни щети.
- Тръбопроводите и арматурата трябва да се монтират, промият и проверят в съответствие с валидните норми.
- Трябва да бъдат спазвани валидните в съответните страни предписания за инсталиране.
- Арматурата не може да се използва във връзка с проточен нагревател.

Технически д нни

Работно налягане:	макс. 1 МПа
Препоръчително работно налягане:	0,1 - 0,5 МПа
Контролно налягане:	1,6 МПа
(1 МПа = 10 bar = 147 PSI)	
Температура на горещата вода:	макс. 70 °C
Препоръчителна температура на горещата вода:	65 °C
Термична дезинфекция:	макс. 70 °C / 4 мин
Продуктът е разработен само за питейна вода!	

Опис ние н символите



Не използвайте силикон, съдържащ оцетна киселина!



Юстир не (вижте стр.)

Настройте ограничението за топлата вода



Р змери (вижте стр. 36)



Ди гр м н поток

(вижте стр. 38)

- ① Мощност на потока смесител
- ② Мощност на потока ръчен разпръсквател 1B



Обслужв не (вижте стр. 35)

Поради конструкцията на арматурата на бидето по време на работата на ръчния разпръсквател от изходящия накрайник на арматурата изтича малко вода.

Hansgrohe препоръчва, сутрин и след по-продължително спиране първият половин литър да не се използва като питейна вода.



Почиств не

от приложената брошура.



Сервизни ч сти (вижте стр. 39)



Специ лни прин длежности

(не се съдържа в обема на доставката)

Уплътнение #98996000



Контролен зн к (вижте стр. 44)



Монт ж вижте стр. 31



Udhëzime sigurie

- △ Për të evituar lëndimet e pickimeve ose të prerjeve gjatë procesit të montimit duhet që të vishni doreza.
- △ Produkti duhet të përdoret vetëm qëllimet e banjave, të higjienës dhe të larjes së trupit.
- △ Ndryshimet e mëdha të presionit mes lidhjeve të ujit të ftohtë dhe atij të ngrohtë duhen ekuilibruar.

Udhëzime për montimin

- Përpara montimit duhet që produkti të kontrollohet për dëmtime nga transporti. Pas instalimit nuk do të njihet asnjë dëmtim nga transporti ose dëmtim i sipërfaqes.
- Tubacionet dhe rubinetet duhet që të montohen, të shpëlahen dhe të kontrollohen sipas standardeve në fuqi
- Duhet të respektohen linjat udhëzuese të instalimit, të vlefshme për vendet respektive.
- Armatura nuk mund të përdoret në kombinim me një ngrohës elektrik të ujit.

Të dhëna teknike

Presioni gjatë punës	maks. 1 MPa
Presioni i rekomanduar:	0,1 - 0,5 MPa
Presioni për provë:	1,6 MPa
(1 MPa = 10 bar = 147 PSI)	
Temperatura e ujit të ngrohtë	maks. 70 °C
Temperatura e rekomanduar e ujit të ngrohtë:	65 °C
Dezinfektim Termik:	maks. 70 °C / 4 min

Produkti është projektuar ekskluzivisht për ujë të pijshëm!

Përshkrimi i simbolit



Mos përdorni silikon që në përbërje ka acid acetik.



Justimi (shih faqen)

Regjistroni kufirin e ujit te ngrohte



Përmasat (shih faqen 36)



Diagrami i qarkullimit

(shih faqen 38)

- ① Kapaciteti i rrjedhjes së rubinetit me ujë të përzier
- ② Kapaciteti i rrjedhjes së spërkatëses së dorës 1B



Përdorimi (shih faqen 35)

Për shkak të ndërtimit të armatures së bidesë, gjatë kohës që koka e dushit është në punë e sipër, nga armatura mund të dale një sasi e vogël uji.

Hansgrohe rekomandon që në mëngjes ose pas periudhave të gjata që gjysmë litri i parë mos të pihet



Pastrimi

shikoni broshurën bashkëngjitur.



Pjesët e servisit (shih faqen 39)



Pajisje të posaçme (nuk përfshihet në vëllimin e furnizimit)

Shtupa #98996000



Shenja e kontrollit (shih faqen 44)





وصف الرمز

هام! لا تستخدم السليكون الذي يحتوي على أحماض!



الضبط (راجع صفحة)

قم بضبط محدد الماء الساخن



أبعاد (راجع صفحة 36)



رسم للصراف

(راجع صفحة 38)

① معدل تدفق المياه من الخلاط

② معدل تدفق المياه من الدش اليدوي 1B



التشغيل (راجع صفحة 35)

تخرج كمية قليلة من الماء من منفذ وحدة البيديه أثناء استخدام الدش اليدوي وفقاً لتصميم وحدة البيديه.



تنصح شركة هانزجروهي Hansgrohe بعدم استخدام أول نصف لتر من الماء لغرض الشرب وذلك في الصباح أو بعد توقف استخدام الماء لفترات طويلة نسبياً.

التنظيف

راجع والكتيب المرفق



قطع الغيار (راجع صفحة 39)



ملحقات خاصة (غير مدرج مع المحتويات المسلمة)



حلقة منع التسرب #98996000

شهادة اختبار (راجع صفحة 44)



⚠️ تنبيهات الأمان

⚠️ يجب إرتداء قفازات لليد أثناء التركيب لتجنب حدوث أخطار الإنحشار أو الجروح.

⚠️ لا يجب استخدام نظام الدش إلا في أغراض الاستحمام والأغراض الصحية وأغراض تنظيف الجسم.

⚠️ يجب أن يكون تيار الماء الساخن والماء البارد متعادلين في الضغط.

تعليمات التركيب

- قبل القيام بعملية التركيب، يجب فحص المنتج للتأكد من خلوه من أية تلفيات ناتجة عن النقل. بعد القيام بعملية التركيب، لن يتم الاعتراف بوجود أية تلفيات سطحية أو تلفيات ناتجة عن عملية النقل.
- يجب تركيب وغسيل واختيار التوصيلات وخلطات المياه طبقاً للمعايير السارية.
- يجب مراعاة القواعد الخاصة بالتركيب وأعمال السباكة وفقاً للوائح الخاصة بكل بلد.
- لا يمكن استخدام خلاط الماء مع جهاز تسخين الماء الفوري.

المواصفات الفنية

- ضغط التشغيل: الحد الأقصى 1 ميجاباسكال
- ضغط التشغيل الموصى به: 0,1 - 0,5 ميجاباسكال
- ضغط الاختبار: 1,6 ميجاباسكال (1 ميجاباسكال = 10 بار = PSI 147)
- درجة حرارة الماء الساخن: الحد الأقصى 70°C
- درجة الحرارة الموصى بها للماء الساخن: 65°C
- تعقيم حراري: الحد الأقصى 70°C / 4 الدقيقة

المنتج مخصص فقط لماء الشرب!



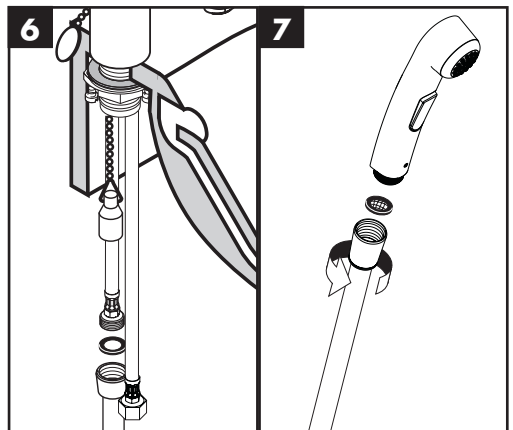
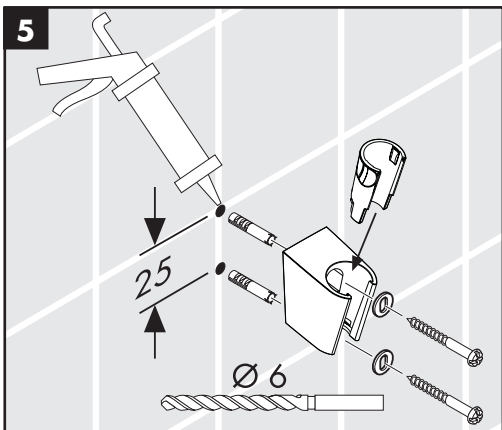
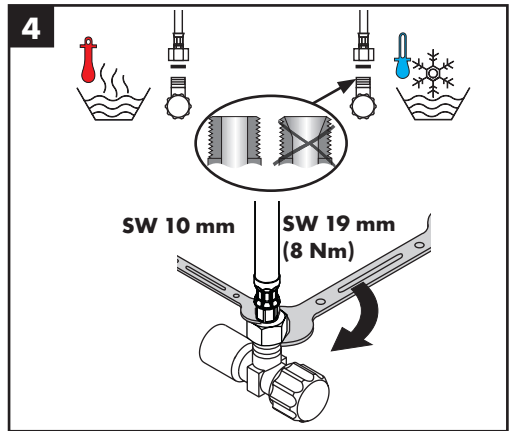
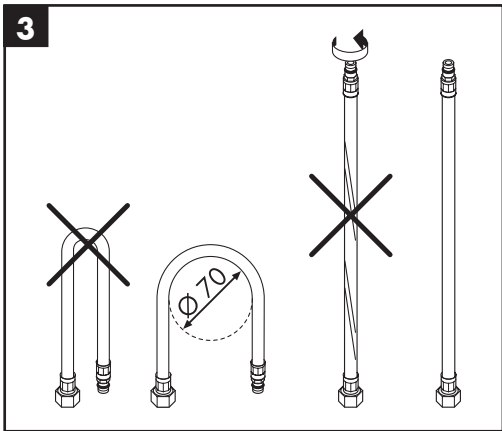
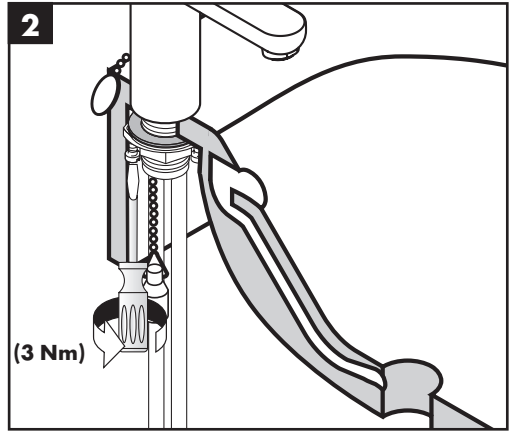
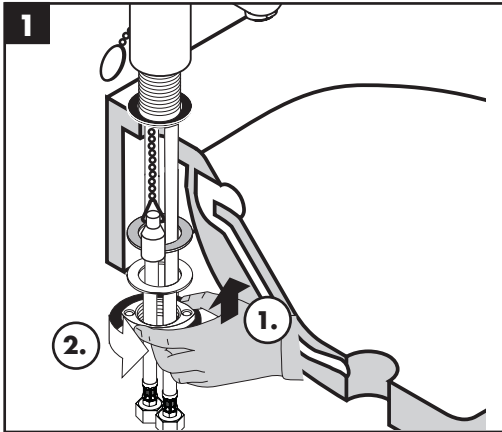

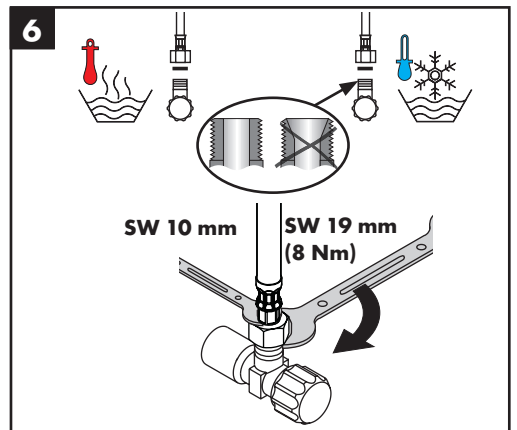
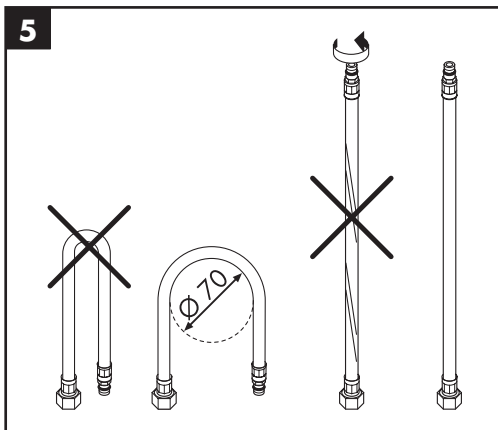
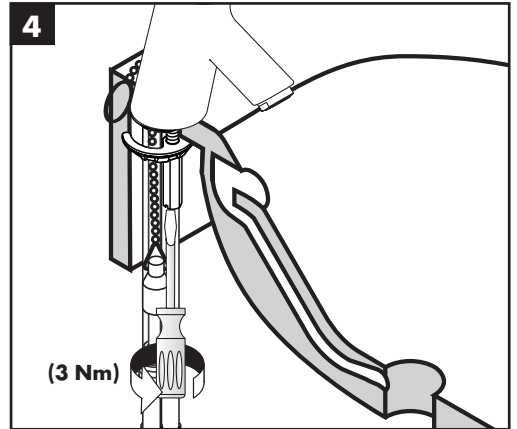
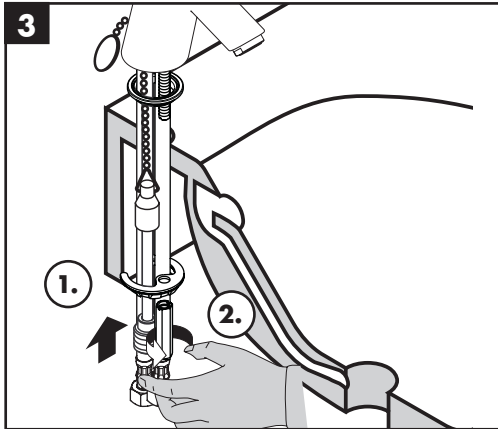
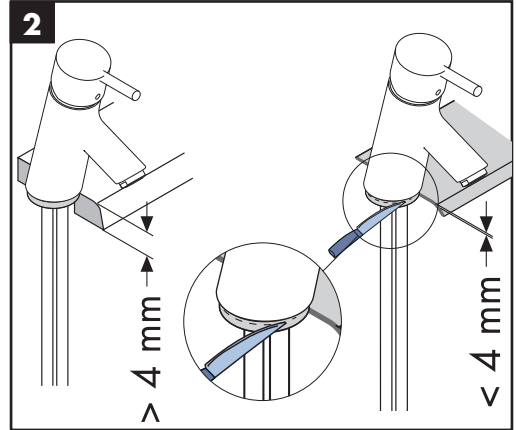
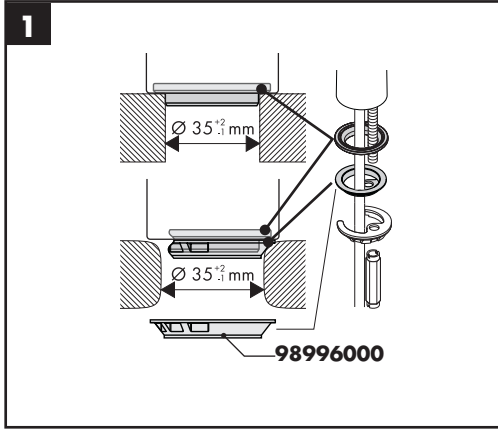

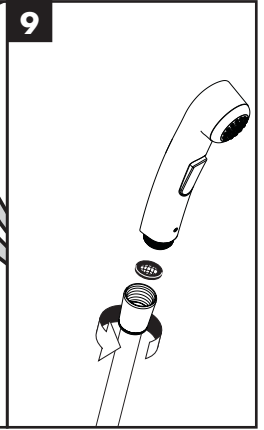
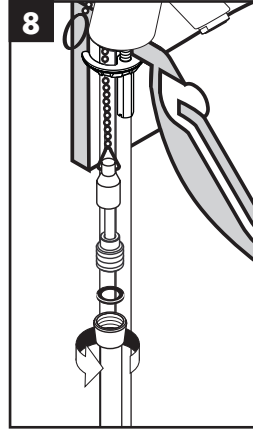
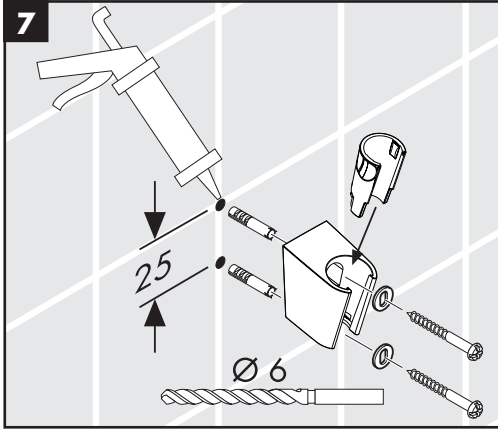

Metris E 31170000 / Talis E² 31165000 / Talis S² 32140000 / Focus 31926000 /
Focus S 37121000 / Metris S 31160000 / Metris 31285000 / Focus 100 31927000

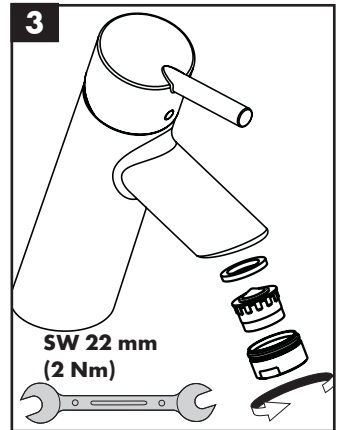
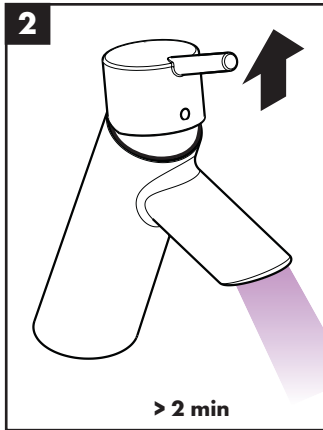
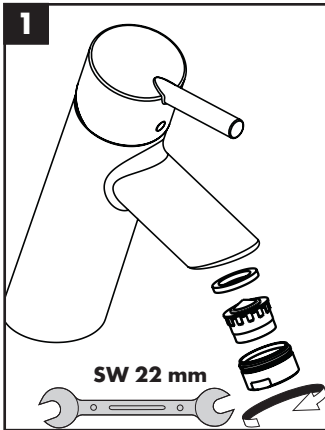



60 °C



10 °C



0,3 MPa
0,3 МП
میجابسکال 0,3

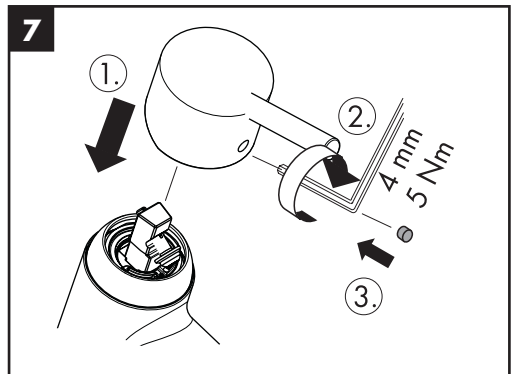
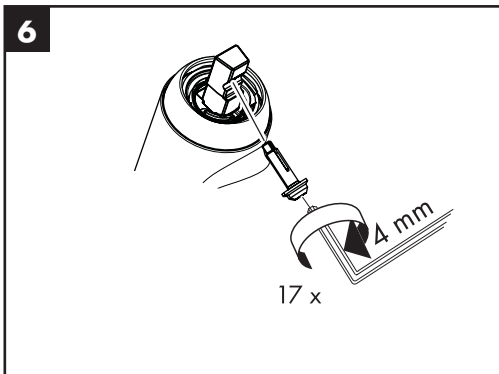
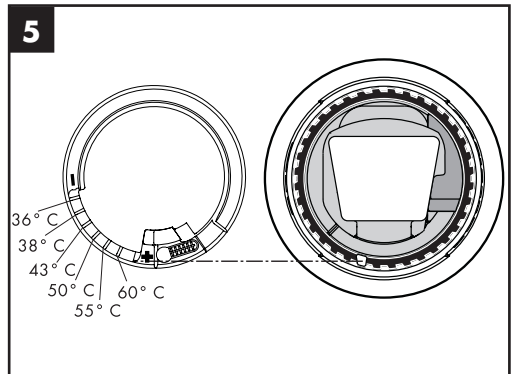
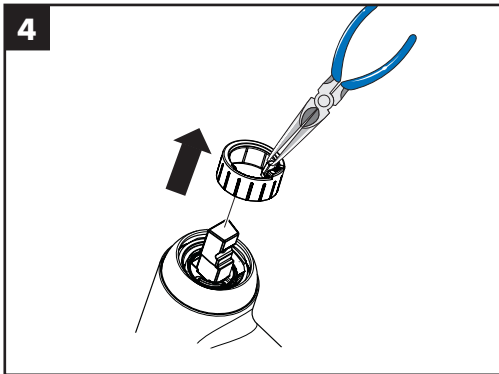
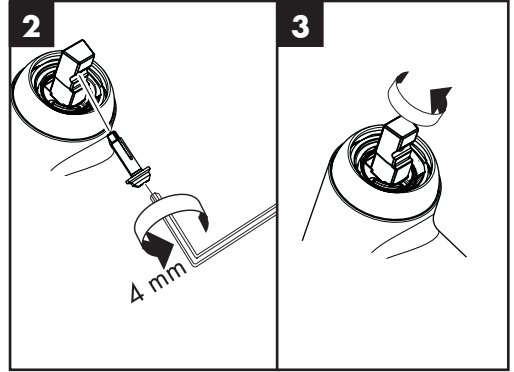
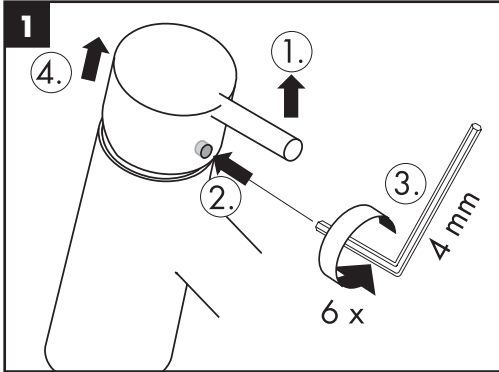

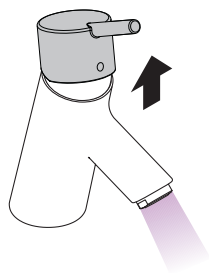

öffnen / ouvert / open / aperto / abierto / open / åbne /
 abrir / otworzyć / otevřít / otvorit / 开 / открыть / nyitás /
 avaaminen / öppna / atidaryti / Отваранье / açmak /
 deschide / ανοικτό / odpreti / avage / atvērt /
 otvoriti / åpne / отваряне / hare / فتح

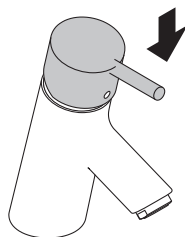

schließen / fermé / close / chiudere / cerrar / sluiten /
 lukke / fechar / zamknąć / zavřít / uzavrieť / 关 /
 закрыть / bezárás / sulkeminen / stänga / uždaryti /
 Zatvaranje / kapatmak / închide / κλειστό /
 zapreti / sulgege / aizvērt / zatvori / lukke / затваряне /
 mbylle / إغلاق

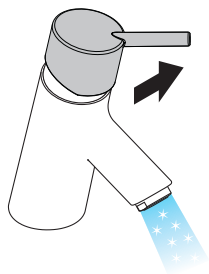

kalt / froid / cold / freddo / frío / koud / koldt / fria /
 zīma / studená / studená / 冷 / холодная / hideg /
 kylmä / kallt / šaltas / Hladno / soğuk / rece / κρύο /
 mrzlo / külm / auksts / hladno / kaldt / студено / i ftohtë /
 بارد

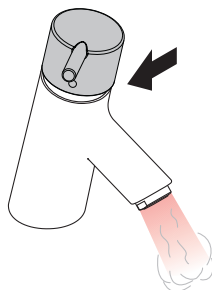

warm / chaud / hot / caldo / caliente / warm / varmt /
 quente / ciepła / teplá / teplá / 热 / горячая / meleg /
 lämmin / varmt / karštas / Vruća voda / sıcak / cald /
 ζεστό / toplo / kuum / karsts / topla / varm / тепло /
 i ngrohtë / ساخن

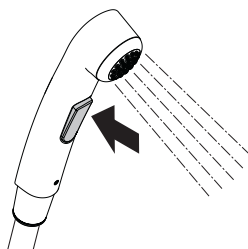
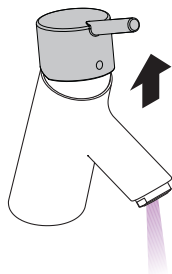



Focus

31926000

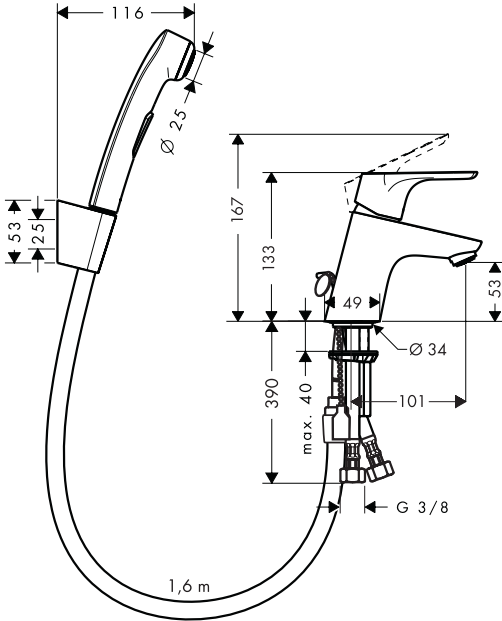

Focus S

37121000

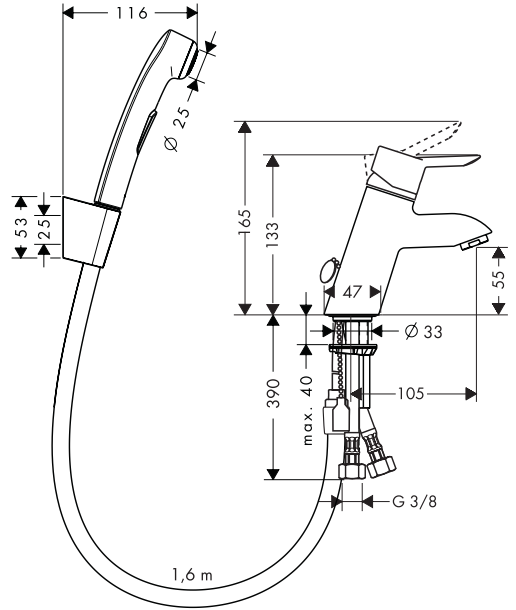

Metris S

31160000

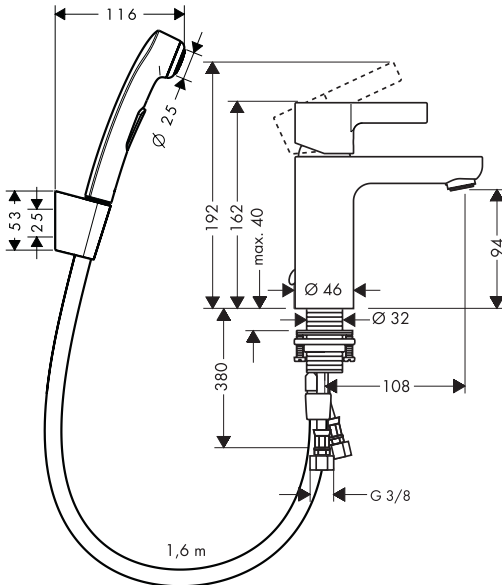

Metris E

31170000

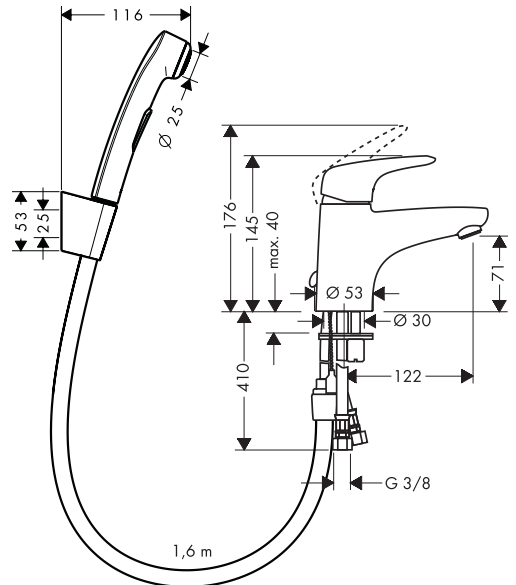

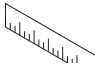

Talis E²
31165000

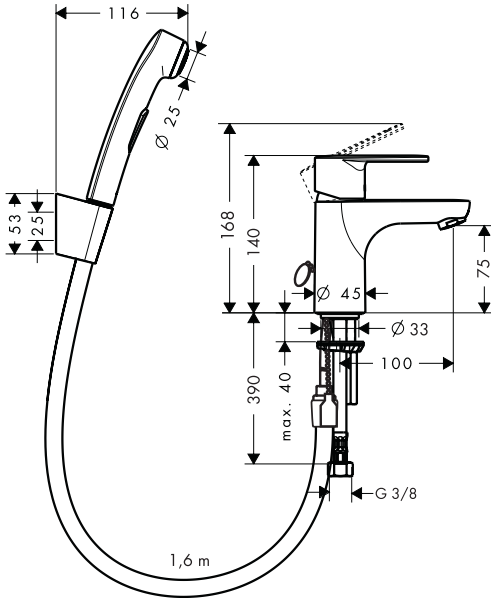

Talis S²
32140000

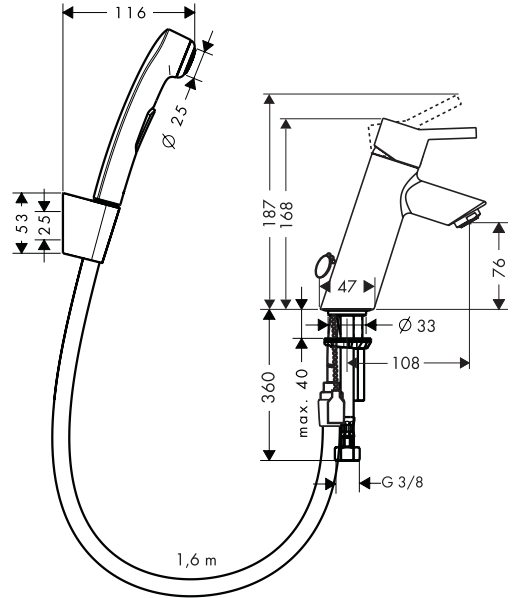

Metris
31285000

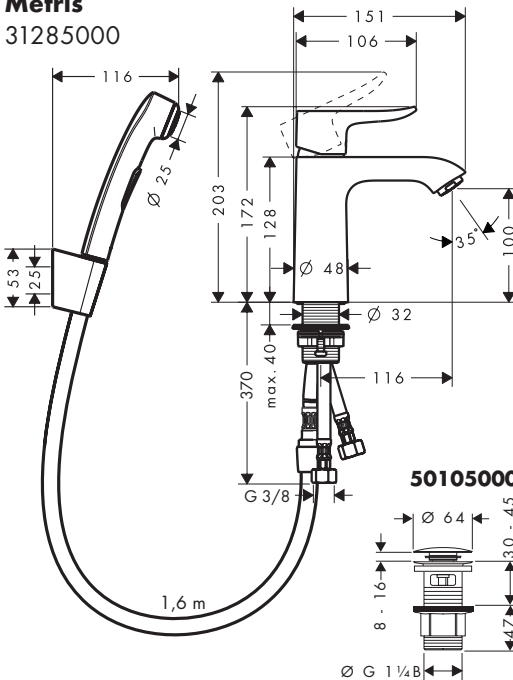

Focus 100
31927000

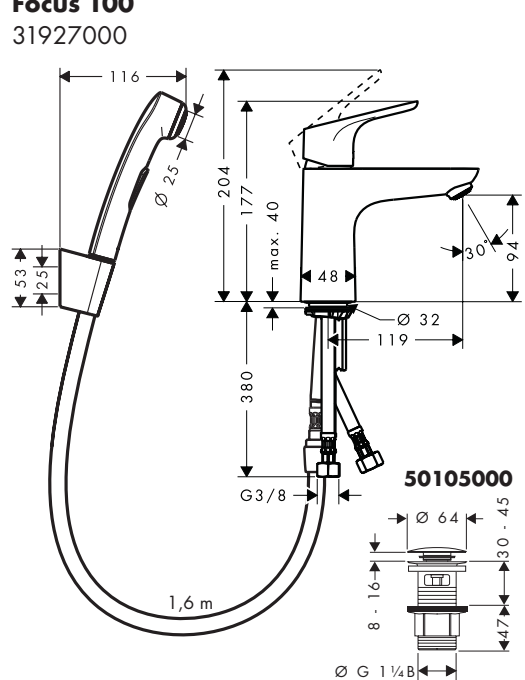



Focus E² 31926000 / **Focus S** 37121000 /
Metris S 3116000 / **Metris E** 3117000 /
Talis E² 31165000 / **Talis S²** 3214000 /
Metris 31285000 / **Focus 100** 31927000

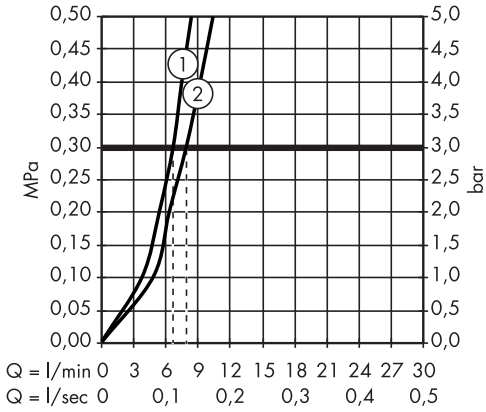



Focus
31926000

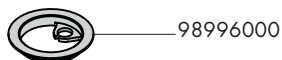
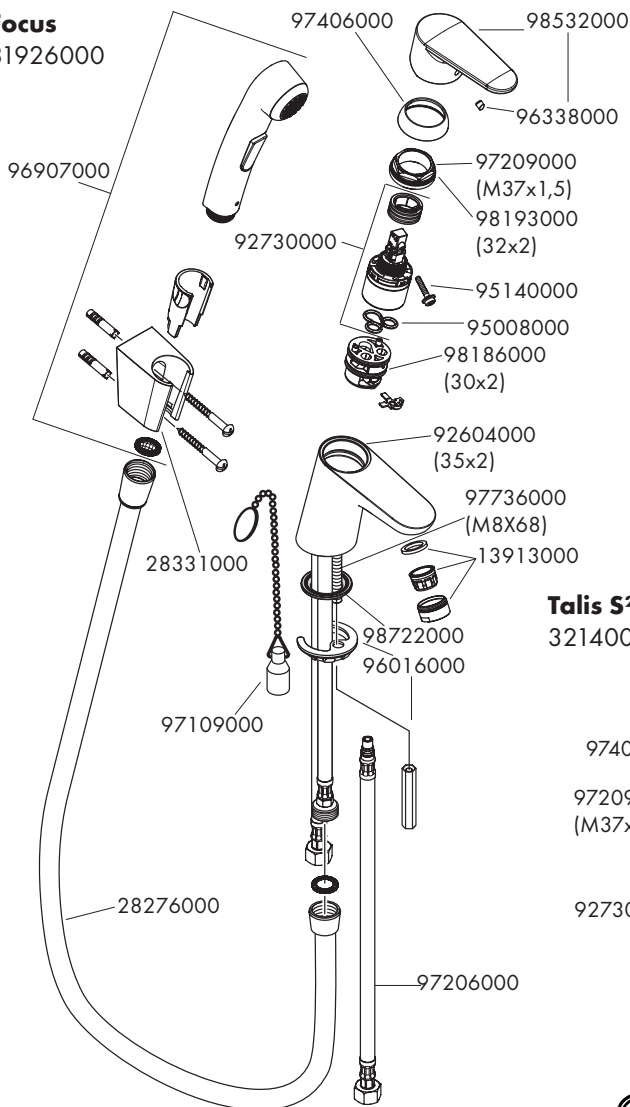

Talis S²
32140000

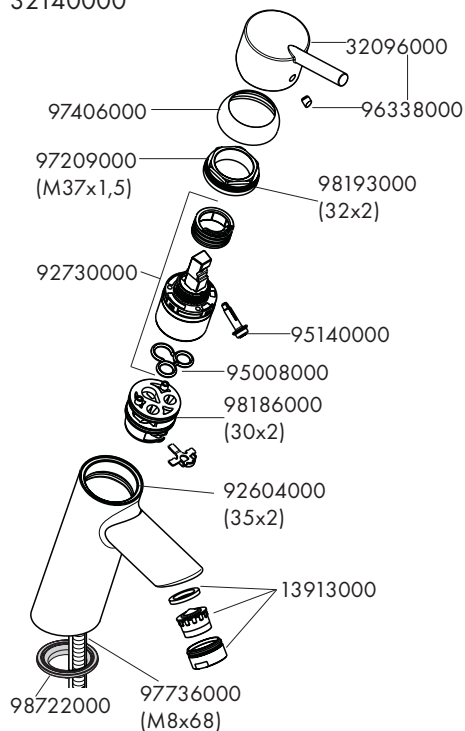



Focus S 37121000

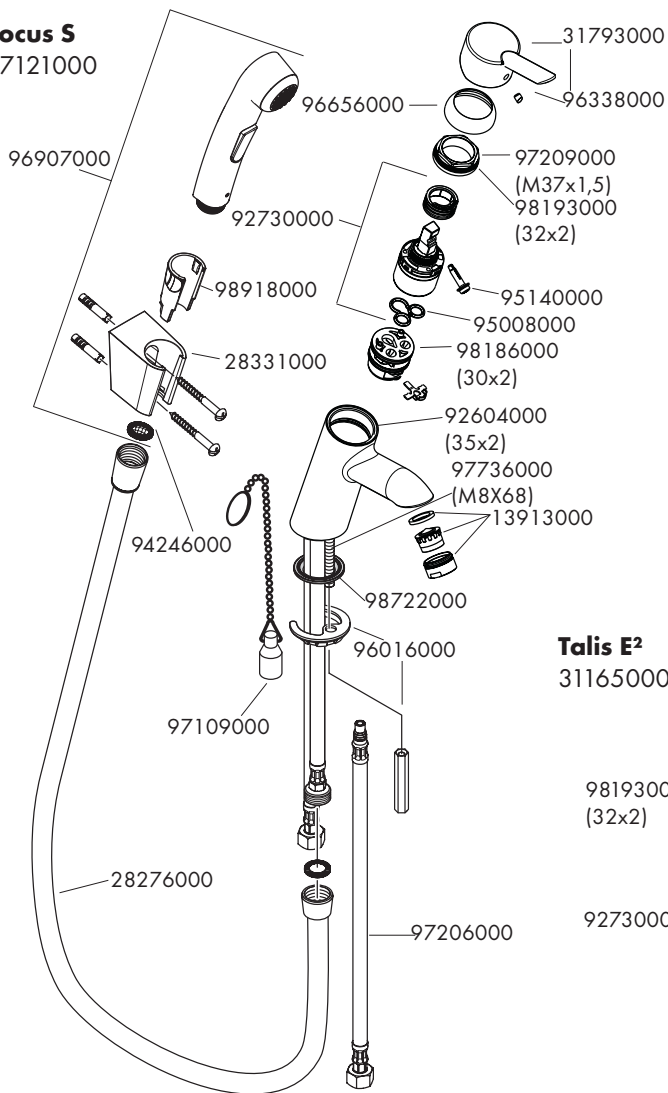

Talis E² 31165000

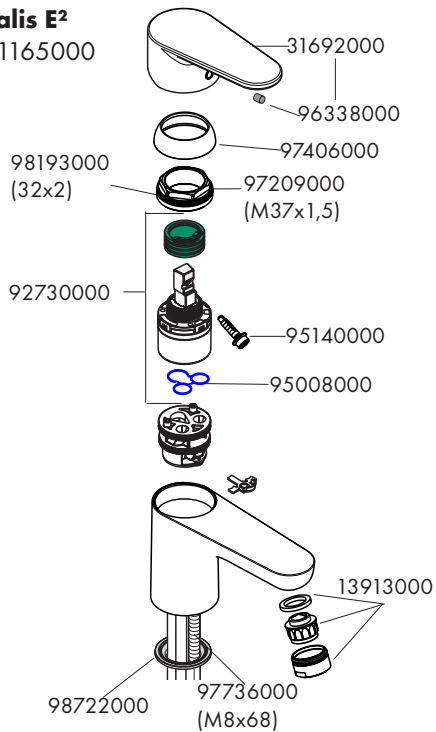



Metris S 31160000

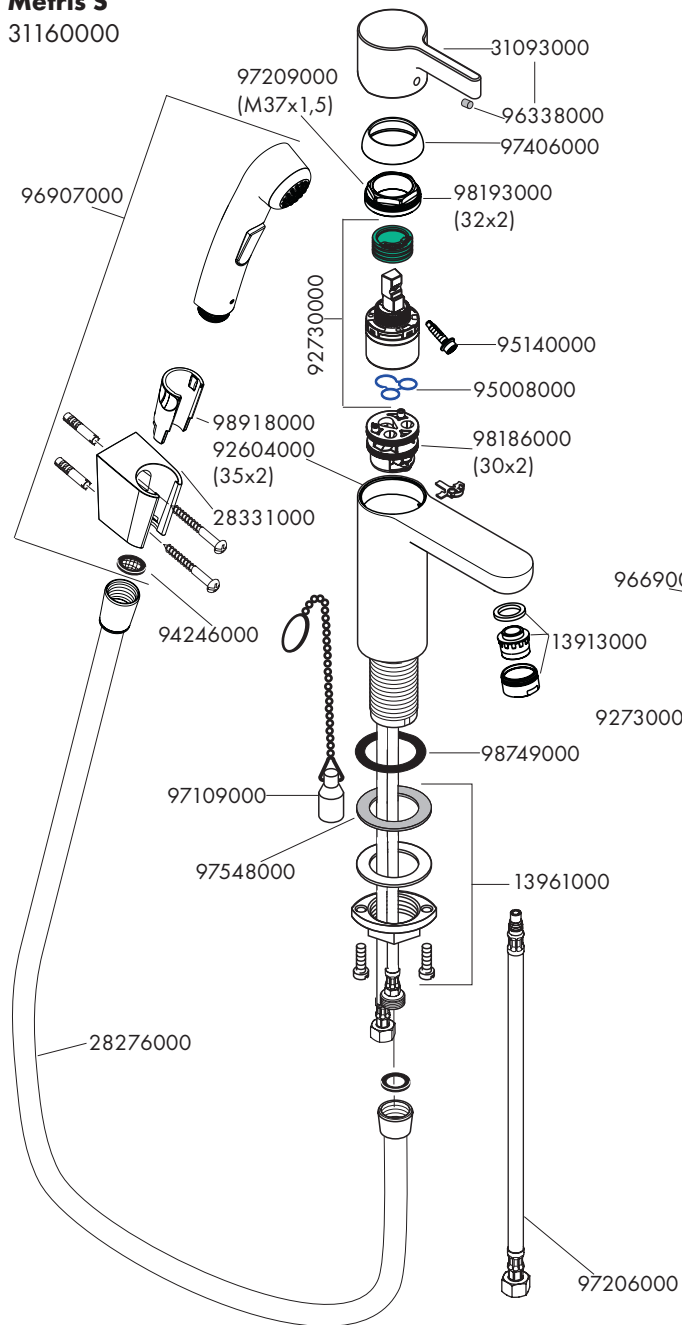

Metris E 31170000

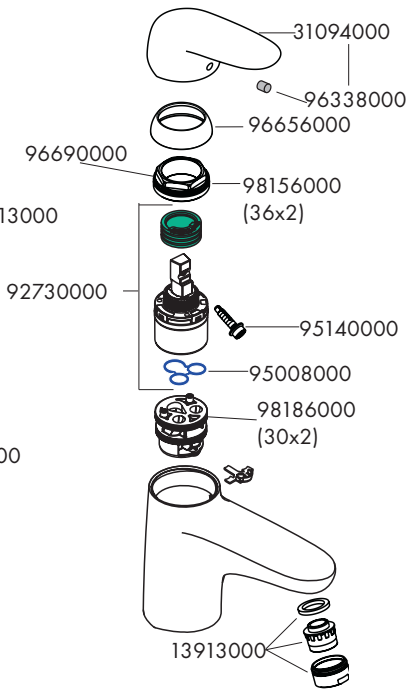



Metris
31285000

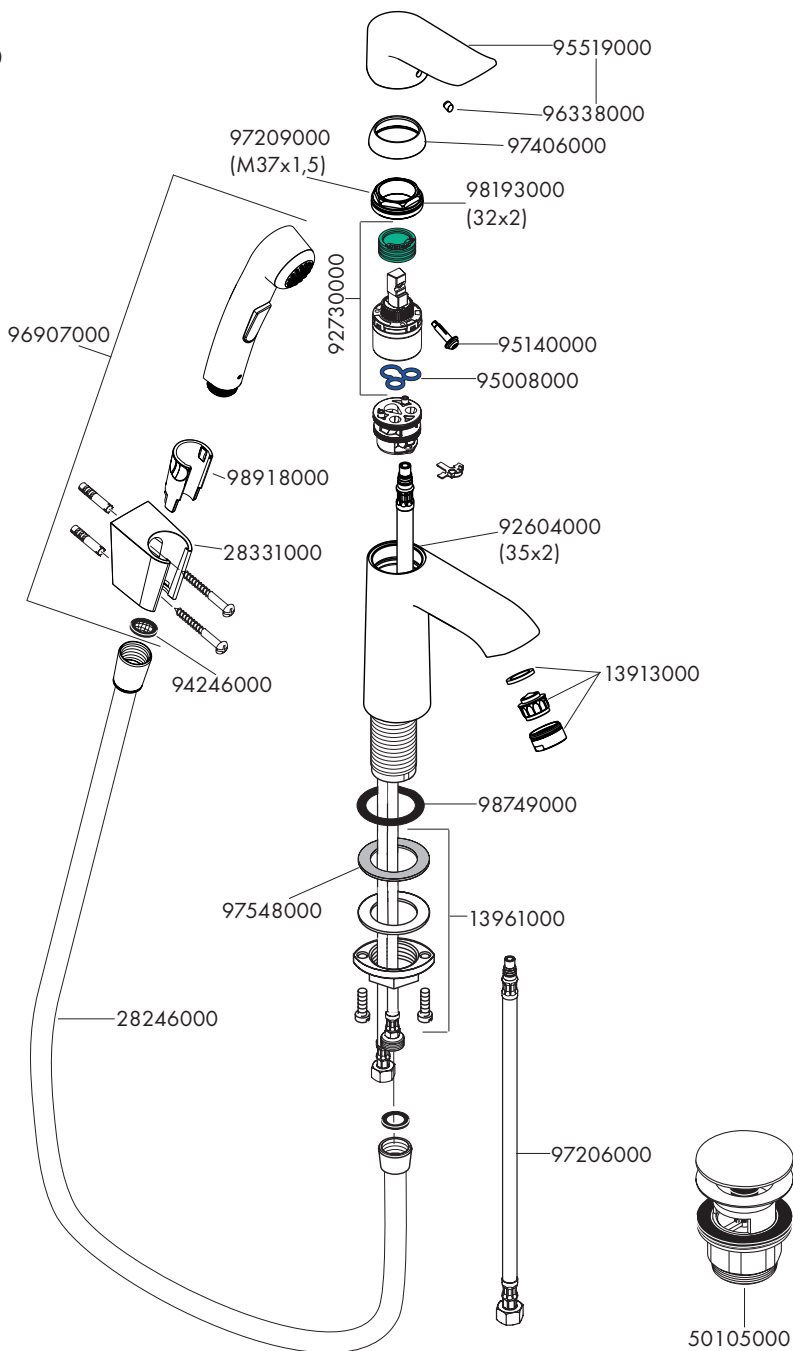



Focus 100

31927000

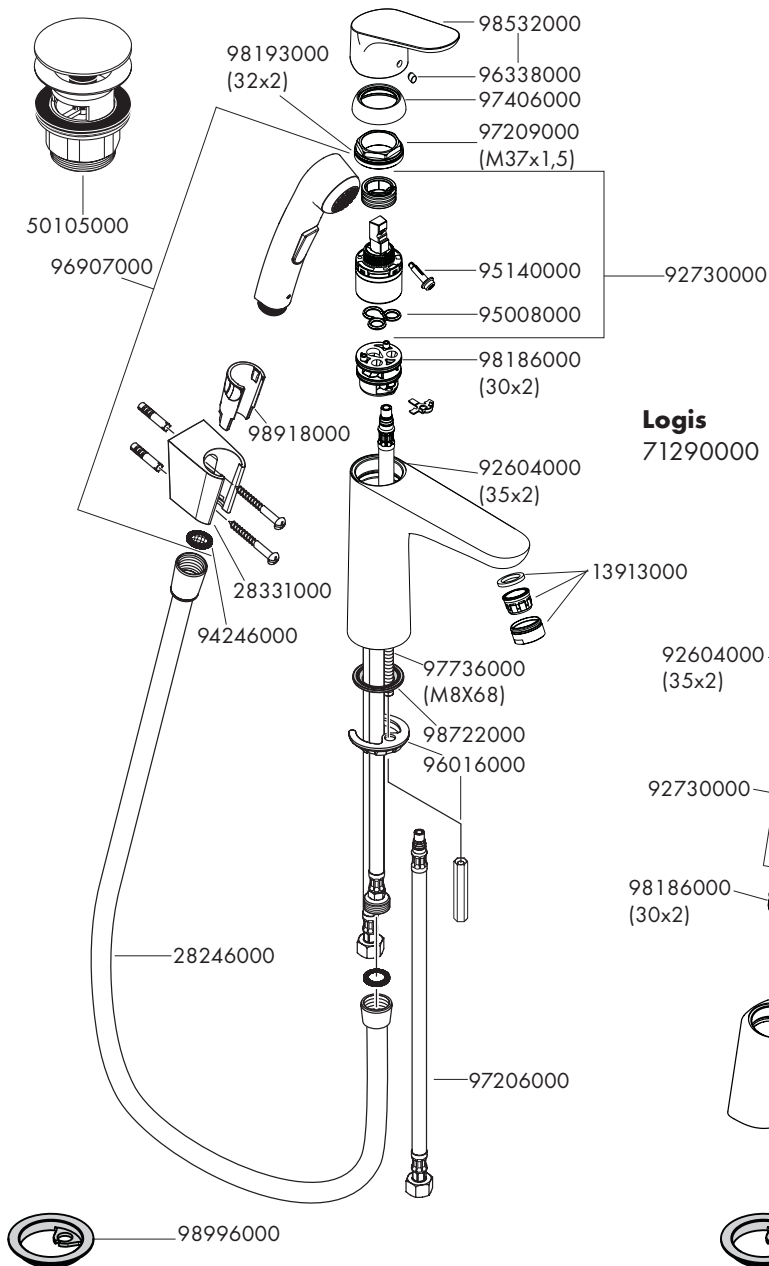

Logis

71290000

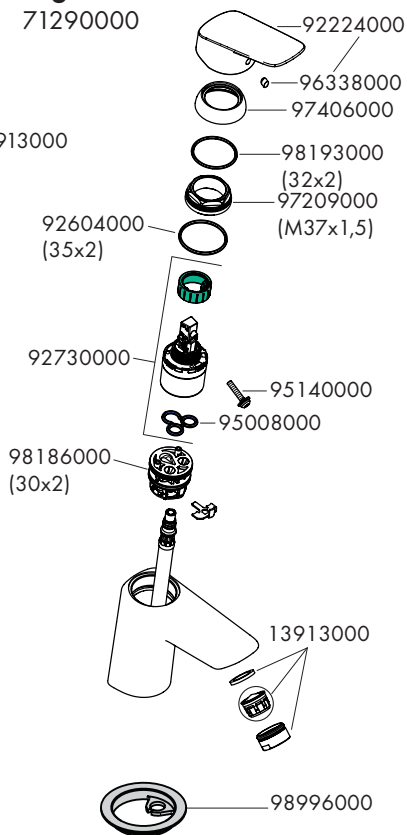



P-IX

DVGW

SVGW

WRAS

ACS

ETA



GODKENDT
TIL DRIKKEVAND

31160000	P-IX 19432/IAO					VD 1.42/18274	X
31170000	P-IX 19431/IAO					VD 1.42/18274	X
31165000	P-IX 19430/IAO					VD 1.42/20359	X
31285000	P-IX 19941/IAO					VD 1.42/19733	X
31926000	P-IX 19240/IAO					VD 1.42/18476	X
31927000							
32140000	P-IX 19429/IAO					VD 1.42/19886	X
37121000	P-IX 19138/IAO					VD 1.42/18274	X

31160000



31170000



31165000



31285000



31926000



32140000



37121000



ОФИЦИАЛЬНЫЙ ДИЛЕР В УКРАИНЕ:

storgom.ua

ГРАФИК РАБОТЫ:

Пн. – Пт.: с 8:30 по 18:30

Сб.: с 09:00 по 16:00

Вс.: с 10:00 по 16:00

КОНТАКТЫ:

+38 (044) 360-46-77

+38 (066) 77-395-77

+38 (097) 77-236-77

+38 (093) 360-46-77

Детальное описание товара:

<https://storgom.ua/product/hansgrohe-194399.html>

Другие товары: <https://storgom.ua/gigieniceskij-dus.html>