

DE	Gebrauchsanleitung / Montageanleitung	2
FR	Mode d'emploi / Instructions de montage	3
EN	Instructions for use / assembly instructions	4
IT	Istruzioni per l'uso / Istruzioni per Installazione	5
ES	Modo de empleo / Instrucciones de montaje	6
NL	Gebruiksaanwijzing / Handleiding	7
DK	Brugsanvisning / Monteringsvejledning	8
PT	Instruções para uso / Manual de Instalação	9
PL	Instrukcja obsługi / Instrukcja montażu	10
CS	Návod k použití / Montážní návod	11
SK	Návod na použitie / Montážny návod	12
ZH	用户手册 / 组装说明	13
RU	Руководство пользователя / Инструкция по монтажу	14
FI	Käyttöohje / Asennusohje	15
SV	Bruksanvisning / Monteringsanvisning	16
LT	Vartotojo instrukcija / Montavimo instrukcijos	17
HR	Upute za uporabu / Uputstva za instalaciju	18
TR	Kullanım kılavuzu / Montaj kılavuzu	19
RO	Manual de utilizare / Instrucțiuni de montare	20
EL	Οδηγίες χρήσης / Οδηγία συναρμολόγησης	21
SL	Navodilo za uporabo / Navodila za montažo	22
ET	Kasutusjuhend / Paigaldusjuhend	23
LV	Lietošanas pamācība / Montāžas instrukcija	24
SR	Uputstvo za upotrebu / Uputstvo za montažu	25
NO	Bruksanvisning / Montasjeveiledning	26
BG	Инструкция за употреба / Ръководство за монтаж	27
SQ	Udhëzuesi i përdorimit / Udhëzime rreth montimit	28
AR	دليل الاستخدام / تعليمات التجميع	29
HU	Használati útmutató / Szerelési útmutató	30

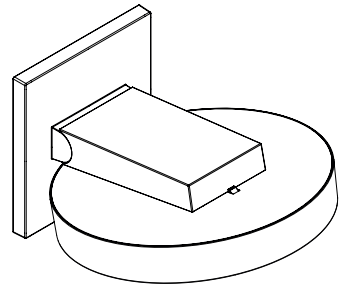

Rainfinity 250 3jet
26232XXX

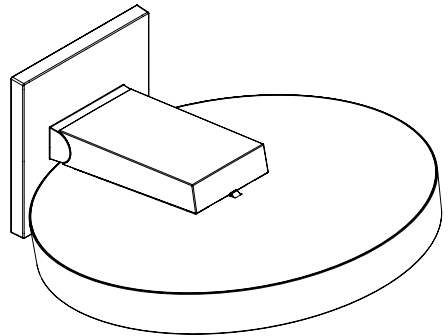

Rainfinity 360 3jet
26234XXX



Sicherheitshinweise

- ⚠ Bei der Montage müssen zur Vermeidung von Quetsch- und Schnittverletzungen Handschuhe getragen werden.
- ⚠ Der Kopfbrausearm ist nur für das Halten der Kopfbrause ausgelegt, er darf nicht mit weiteren Gegenständen belastet werden!
- ⚠ Das Produkt darf nur zu Bade-, Hygiene- und Körperreinigungszwecken eingesetzt werden.

Montagehinweise

- Vor der Montage muss das Produkt auf Transportschäden untersucht werden. Nach dem Einbau werden keine Transport- oder Oberflächenschäden anerkannt.
- Die Leitungen und die Armatur müssen nach den gültigen Normen montiert, gespült und geprüft werden.
- Die in den Ländern jeweils gültigen Installationsrichtlinien sind einzuhalten.
- Bei der Montage des Produktes durch qualifiziertes Fachpersonal ist darauf zu achten, dass die Befestigungsfläche im gesamten Bereich der Befestigung plan ist (keine vorstehenden Fugen oder Fliesenversatz), der Wandaufbau für eine Montage des Produktes geeignet ist und keine Schwachstellen aufweist.
- Die Schmutzfangsiebe müssen eingebaut werden, um Schmutzeinspülungen aus dem Leitungsnetz zu vermeiden. Schmutzeinspülungen können die Funktion beeinträchtigen und/oder zu Beschädigungen an Funktionsteilen der Armatur führen, für hieraus ergebende Schäden haftet Hansgrohe nicht.
- Das Produkt ist nicht für die Verwendung in Verbindung mit einem Dampfbad vorgesehen!

Technische Daten

Betriebsdruck:	max. 1 MPa
Empfohlener Betriebsdruck:	0,17 - 0,4 MPa
Prüfdruck:	1,6 MPa
	(1 MPa = 10 bar = 147 PSI)
Heißwassertemperatur:	max. 60 °C
Empfohlene Heißwassertemperatur:	42 °C
Thermische Desinfektion:	max. 70 °C / 4 min

- Das Produkt ist ausschließlich für Trinkwasser konzipiert!

- Dieses Produkt kann nicht in Verbindung mit hydraulisch und thermisch gesteuerten Durchlauferhitzern eingesetzt werden.

Symbolerklärung



Kein essigsäurehaltiges Silikon verwenden!



Maße (siehe Seite 44)



Durchflussdiagramm
(siehe Seite 44)



Montagebeispiele (siehe Seite 32)



In diesem Bereich ist eine Wandverstärkung notwendig.



Mitte Duschwanne



Warmwasser



Kaltwasser



Serviceteile (siehe Seite 31)

XXX = Farbcodierung

000 = Chrom

700 = Mattweiß



Sonderzubehör (siehe Seite 31)
(nicht im Lieferumfang enthalten)



• Verlängerung 25 mm #13595000



• Ausgleichsset 1° #95521000



Reinigung (siehe Seite 39)



Bedienung (siehe Seite 46)

Störung

Kopfbrause stark undicht

Ursache

- Kopfbrause verschmutzt / verkalkt

Abhilfe

- Kopfbrause reinigen / entkalken





Consignes de sécurité

- △ Lors du montage, porter des gants de protection pour éviter toute blessure par écrasement ou coupure.
- △ Le bras de la douche n'est conçu que pour tenir la douche et ne doit pas servir à la suspension d'autres objets !
- △ Le produit ne doit servir qu'à se laver et à assurer l'hygiène corporelle.

Instructions pour le montage

- Avant son montage, s'assurer que le produit n'a subi aucun dommage pendant le transport. Après le montage, tout dommage de transport ou de surface ne pourra pas être reconnu.
- Les conduites et la robinetterie doivent être montés, rincés et contrôlés selon les normes en vigueur.
- Les directives d'installation en vigueur dans le pays concerné doivent être respectées.
- Lors du montage de ce produit par du personnel qualifié, veiller à ce que la surface de fixation soit bien plane dans toute la zone de fixation (pas de dépassement de joints ou de déport de carreaux), à ce que le mur se prête au montage du produit et ne présente aucun point fragile.
- Les tamis doivent être mis en place pour éviter aux saletés de s'infiltrer dans le réseau de conduites. Les saletés peuvent porter préjudice au fonctionnement et/ou provoquer des endommagements au niveau des éléments fonctionnels de la robinetterie. En cas de dommages en résultant, la responsabilité de Hansgrohe ne pourra pas être mise en cause.
- Le produit n'est pas prévu pour une utilisation en liaison avec un bain à vapeur.

Informations techniques

Pression de service autorisée: max. 1 MPa
 Pression de service conseillée: 0,17 - 0,4 MPa
 Pression maximum de contrôle: 1,6 MPa
 (1 MPa = 10 bar = 147 PSI)

Température d'eau chaude: max. 60 °C
 Température recommandée: 42 °C
 Désinfection thermique: max. 70 °C / 4 min

- Le produit est exclusivement conçu pour de l'eau potable!

- Les mitigeurs Hansgrohe ne doivent pas être utilisés avec des chauffe-eau instantané à commande hydraulique ou thermique.

Description du symbole



Ne pas utiliser de silicone contenant de l'acide acétique!



Dimensions (voir pages 44)

Diagramme du débit

(voir pages 44)



Exemples de montage

(voir pages 32)



Le mur n'a pas besoin d'être renforcé à cet endroit



Centre cuvette de douche



Eau chaude



Eau froide



Pièces détachées (voir pages 31)

XXX = Couleurs

000 = Chromé

700 = Matt White



Accessoires en option

(voir pages 31)

(ne fait pas partie de la fourniture)

- jeu de rallonge 25 mm #13595000

- Set d'égalisation 1° #95521000



Nettoyage (voir pages 39)



Instructions de service

(voir pages 46)

Dysfonctionnement

Origine

Solution

Manque d'étanchéité important de la douche - Douchette encrassée / entartrée - Nettoyer / détartrer la douche



Safety Notes

- △ Gloves should be worn during installation to prevent crushing and cutting injuries.
- △ The arm of the shower head is intended only to hold the shower head. Do not load it down with other objects!
- △ The product may only be used for bathing, hygienic and body cleaning purposes.

Installation Instructions

- Prior to installation, inspect the product for transport damages. After it has been installed, no transport or surface damage will be honoured.
- The pipes and the fixture must be installed, flushed and tested as per the applicable standards.
- The plumbing codes applicable in the respective countries must be observed.
- During installation of the product by qualified trained personnel, make sure that the entire fastening surface is even and smooth (no protruding seams or tile offset), that the finish of the wall is suitable to apply the product and has no weak points.
- The mesh washers must be installed to protect against incoming dirt by pipework. Incoming dirt can impair the function and/or lead to damages on functional parts of the fixture; Hansgrohe will not be held liable for resulting damages.
- The product is not designed to be used with steam baths!

Technical Data

Operating pressure: max. 1 MPa
 Recommended operating pressure: 0,17 - 0,4 MPa
 Test pressure: 1,6 MPa
 (1 MPa = 10 bar = 147 PSI)

Hot water temperature: max. 60°C
 Recommended hot water temp.: 42°C
 Thermal disinfection: max. 70°C / 4 min

- The product is exclusively designed for drinking water!
- This mixer cannot be used in conjunction with hydraulically, electronically or thermally controlled instantaneous heaters.

Symbol description



Do not use silicone containing acetic acid!

Fault

Cause

Remedy

Head shower extremely leaky

- Head shower soiled / scaled

- Clean / descale head shower



Dimensions (see page 44)



Flow diagram (see page 44)



Installation example (see page 32)



The wall must be reinforced in this area.



Center shower tub



Warm water



Cold water



Spare parts (see page 31)

XXX = Colors

000 = Chrome Plated

700 = Matt White



Special accessories (see page 31)
(order as an extra)

• extension 25 mm #13595000

• levelling set 1° #95521000



Cleaning (see page 39)



Operation (see page 46)





Indicazioni sulla sicurezza

- △ Durante il montaggio, per evitare ferite da schiacciamento e da taglio bisogna indossare guanti protettivi.
- △ Il braccio del soffione della doccia è progettato per sostenere solo quest'ultimo, non va sovraccaricato con altri oggetti!
- △ Il prodotto deve essere utilizzato esclusivamente per fare il bagno e per l'igiene del corpo.

Istruzioni per il montaggio

- Prima del montaggio è necessario controllare che non ci siano stati danni durante il trasporto. Una volta eseguito il montaggio, non verranno riconosciuti eventuali danni di trasporto o delle superfici.
- Montare, lavare e controllare tubature e rubinetteria rispettando le norme correnti.
- Vanno rispettate le direttive di installazione nazionali vigenti nel rispettivo paese.
- Per il montaggio del prodotto da personale specializzato qualificato bisogna fare attenzione, che la superficie di fissaggio, in tutto il campo di fissaggio, sia piana (nessuna giunzione sporgente o sfalsamento di piastrella), la costruzione della parete sia adatta al montaggio del prodotto e che non presenti alcun punto debole.
- E' necessario montare i filtri per la raccolta della sporcizia per evitare che eventuali impurità provenienti dalla rete delle tubazioni causino danni. Queste possono infatti compromettere le funzioni e/o causare danni a parti funzionali della rubinetteria. La Hansgrohe non risponde di danni da ciò causati.
- Il prodotto non è predisposto per l'impiego in combinazione con un bagno a vapore.

Dati tecnici

Pressione d'uso:	max. 1 MPa
Pressione d'uso consigliata:	0,17 - 0,4 MPa
Pressione di prova:	1,6 MPa
	(1 MPa = 10 bar = 147 PSI)
Temperatura dell'acqua calda:	max. 60 °C
Temp. dell'acqua calda consigliata:	42 °C
Disinfezione termica:	max. 70 °C / 4 min

- Il prodotto è concepito esclusivamente per acqua potabile!

- I miscelatori non sono compatibili con le caldaie istantanee.

Descrizione simbolo



Non utilizzare silicone contenente acido acetico!



Ingombri (vedi pagg. 44)



Diagramma flusso (vedi pagg. 44)



Esempio di installazione

(vedi pagg. 32)



In questa zona è necessario un rinforzo della parete.



Centro piatto doccia



Acqua calda



Acqua fredda



Parti di ricambio (vedi pagg. 31)

XXX = Trattamento

000 = Cromato

700 = Matt White



Accessori speciali (vedi pagg. 31)

(non contenuto nel volume di fornitura)



- Prolunga 25 mm #13595000



- Elemento per la regolazione in altezza 1° #95521000



Pulitura (vedi pagg. 39)



Procedura (vedi pagg. 46)

Problema

Possibile causa

Rimedio

Doccia di testa non ermetica

- Doccia di testa sporca / calcificata

- Pulire / decalcificare la doccia di testa



Indicaciones de seguridad

- △ Durante el montaje deben utilizarse guantes para evitar heridas por aplastamiento o corte.
- △ El brazo del pulverizador de ducha solo está previsto para soportar el pulverizador de ducha y no debe cargarse con otros objetos!
- △ El producto solo debe ser utilizado para fines de baño, higiene y limpieza corporal.

Indicaciones para el montaje

- Antes del montaje se debe examinarse el producto contra daños de transporte. Después de la instalación no se reconoce ningún daño de transporte o de superficie.
- Los conductos y la grifería deben montarse, lavarse y comprobarse según las normas vigentes.
- Es obligatorio el cumplimiento de las directrices de instalación vigentes en el país respectivo.
- Durante el montaje del producto, mediante personal especializado, se debe asegurar de que la superficie de sujeción en todo el área de la fijación sea plana (sin fugas o azulejos que sobresalgan), que la estructura del muro sea adecuada para el montaje del producto y que no presente puntos débiles.
- Los tamices recogelodos deben ser instalados para evitar las partículas de suciedad procedentes de las tuberías. Infiltraciones de suciedad pueden deteriorar el funcionamiento y/o pueden causar daños en los componentes de las válvulas que no están cubiertos por la garantía de Hansgrohe.
- ¡El producto no ha sido diseñado para uso en conexión con un baño de vapor!

Datos técnicos

Presión en servicio:	max. 1 MPa
Presión recomendada en servicio:	0,17 - 0,4 MPa
Presión de prueba:	1,6 MPa
	(1 MPa = 10 bar = 147 PSI)
Temperatura del agua caliente:	max. 60°C
Temp. recomendada del agua caliente:	42°C
Desinfección térmica:	max. 70°C / 4 min

- El producto ha sido concebido exclusivamente para agua potable.

- Los mezcladores no pueden usarse con calentadores instantáneos mandados hidráulicamente o térmicamente.

Descripción de símbolos



No utilizar silicona que contiene ácido acético!



Dimensiones (ver página 44)



Diagrama de circulación
(ver página 44)



Ejemplos de montaje (ver página 32)



En este sector es necesario un refuerzo del muro.



Centro la plato de ducha



Agua caliente



Agua fría



Repuestos (ver página 31)

XXX = Acabados

000 = Cromado

700 = Matt White



Opcional (ver página 31)

(no incluido en el suministro)



• Prolongación 25 mm #13595000



• set de nivelación 1° #95521000



Limpiar (ver página 39)



Manejo (ver página 46)

Problema

Causa

Solución

Ducha con muchas fugas

- Ducha sucia / calcificada

- Limpiar / descalcificar la ducha





Veiligheidsinstructies

- △ Bij de montage moeten ter voorkoming van knel- en snijwonden handschoenen worden gedragen.
- △ De arm van de hoofddouche is uitsluitend voor het vasthouden van de hoofddouche bedoeld en mag niet met verdere voorwerpen worden belast!
- △ Het product mag alleen voor het wassen, hygiënische doeleinden en voor de lichaamreiniging worden gebruikt.

Montage-instructies

- Vóór de montage moet het product gecontroleerd worden op transportschade. Na de inbouw wordt geen transport- of oppervlakteschade meer aanvaard.
- De leidingen en armaturen moeten gemonteerd, gespoeld en gecontroleerd worden volgens de geldige normen.
- De in de overeenkomstige landen geldende installatierichtlijnen moeten nageleefd worden.
- Bij de montage van het product door gekwalificeerd vakpersoneel moet erop gelet worden dat het montagevlak in het volledige bereik van de bevestiging vlak is (geen uitstekende voegen of verspringende tegels), dat de wand geschikt is voor de montage van het product en geen zwakke plaatsen vertoont.
- De vuilzeefjes moeten ingebouwd worden om te vermijden dat vuil uit het leidingwater meekomt. Vuil uit de leidingen kan de werking negatief beïnvloeden en/of de armatuur beschadigen. Voor daaruit resulterende schade is Hansgrohe niet aansprakelijk.
- Het product is niet voorzien voor gebruik in combinatie met een stoombad!

Technische gegevens

Werkdruk: max.	max. 1 MPa
Aanbevolen werkdruk:	0,17 - 0,4 MPa
Getest bij:	1,6 MPa
	(1 MPa = 10 bar = 147 PSI)
Temperatuur warm water:	max. 60 °C
Aanbevolen warm water temp.:	42 °C
Thermische desinfectie:	max. 70 °C / 4 min

- Het product is uitsluitend ontworpen voor drinkwater!

- Hansgrohe kranen mogen niet in verbinding met hydraulische en thermisch gestuurde geisers geplaatst worden.

Symboolbeschrijving

 Gebruik geen zuurhoudende silicone!

 **Maten** (zie blz. 44)

 **Doorstroombiagram** (zie blz. 44)

 **Montagevoorbeelden** (zie blz. 32)

 In dit bereik is een wandversterking noodzakelijk.

X Midden Douchebak

 Warm water

 Koud water

 **Service onderdelen** (zie blz. 31)

XXX = Kleuren

000 = Verchroomd

700 = Matt White

 **Toebehoren** (zie blz. 31)
(behoort niet tot het leveringspakket)

• Verlengstuk 25 mm #13595000

• nivelleerset 1° #95521000

 **Reinigen** (zie blz. 39)

 **Bediening** (zie blz. 46)

Storing

Hoofdsproeier lekt sterk

Oorzaak

- Hoofdsproeier vuil / verkalkt

Oplossing

- Hoofdsproeier reinigen / ontkalken



Sikkerhedsanvisninger

- △ Ved monteringen skal der bruges handsker for at undgå kvæstelser og snitsår.
- △ Stangen til hovedbruseren er kun beregnet til at holde hovedbruseren. Den må ikke belastes med andre genstande!
- △ Produktet må kun bruges til bade-, hygiejne og kropsurengøring.

Monteringsanvisninger

- Før monteringen skal produktet kontrolleres for transportskader. Efter monteringen godkendes transportskader eller skader på overfladen ikke længere.
- Ledningerne og armaturerne skal monteres, skylles og kontrolleres iht. de gældende standarder.
- Installationsbestemmelserne, der gælder i det enkelte land, skal overholdes.
- Ved montering af produktet igennem kvalificerede fagfolk skal der holdes øje med, at fastgørelsesoverfladen er plan i alle områder hvor produktet monteres (ingen fremragende fuger eller fliseforskydninger), at væggene er velegnet til monteringen af produktet og ikke har svare områder.
- Smudsfangssiernen skal sættes i for at undgå snavs fra rørsystemet. Tilsmudsningen kan påvirke funktionen og/eller føre til skader på armaturets funktionskomponenter. Hansgrohe er ikke ansvarligt for heraf resulterende skader.
- Dette produkt er ikke beregnet til anvendelse i forbindelse med et dampbad!

Tekniske data

Driftstryk:	max. 1 MPa
Anbefalet driftstryk:	0,17 - 0,4 MPa
Prøvetryk:	1,6 MPa
	(1 MPa = 10 bar = 147 PSI)
Varmtvandstemperatur:	max. 60 °C
Anbefalet varmtvandstemperatur:	42 °C
Termisk desinfektion:	max. 70 °C / 4 min

- Produktet er udelukkende beregnet til drikkevand!
- Hansgrohe armaturer kan ikke anvendes i forbindelse med hydraulisk og termisk styrede vandvarmere.

Symbolbeskrivelse



Der må ikke benyttes eddikesyreholdig silikone!



Målene (se s. 44)



Gennemstrømningsdiagram
(se s. 44)



Monteringseksempler (se s. 32)



I dette område er en forstærkning af væggen nødvendigt.



Midt brusekar



Varmt vand



Kold vand



Reservedele (se s. 31)

XXX = Overflade
000 = Krom
700 = Matt White



Specialtilbehør (se s. 31)
(ikke med i leveringsomfang)



• Forlængersæt 25 mm #13595000



• Nivelleringsæt 1° #95521000



Rengøring (se s. 39)



Brugsanvisning (se s. 46)

Fejl

Bruser meget utæt

Årsag

- Bruser tilsmudset / kalket til

Hjælp

- Rengør / afkalk bruser





Avisos de segurança

- ⚠ Durante a montagem devem ser utilizadas luvas de protecção, de modo a evitar ferimentos resultantes de entalamentos e de cortes.
- ⚠ O braço do chuveiro foi concebido apenas para servir de apoio à cabeça do chuveiro, pelo que não pode ser sujeito a cargas de objectos adicionais!
- ⚠ O produto só pode ser utilizado para fins de higiene pessoal.

Avisos de montagem

- Antes da montagem deve-se controlar o produto relativamente a danos de transporte. Após a montagem não são aceites quaisquer danos de transporte ou de superfície.
- As tubagens e a torneira têm que ser montadas, enxaguadas e verificadas de acordo com as normas em vigor.
- A prescrições de instalação válidas nos respetivos países devem ser respeitadas.
- Durante a montagem efectuada por técnicos qualificados deve ter-se em atenção que a superfície de fixação seja plana em toda a sua extensão (sem juntas ou ladrilhos salientes), que a estrutura da parede seja adequada para a montagem do produto e que não apresente pontos fracos.
- Os colectores de sujidade/impurezas têm que ser montados, de modo a evitar o enxaguamento de sujidade proveniente da rede de água. A sujidade proveniente da rede pode influenciar o funcionamento e/ou provocar danos nas peças funcionais do equipamento. A Hansgrohe não se responsabiliza por danos daí resultantes.
- O produto não foi concebido para utilização em combinação com um banho de vapor!

Dados Técnicos

Pressão de funcionamento:	max. 1 MPa
Pressão de func. recomendada:	0,17 - 0,4 MPa
Pressão testada:	1,6 MPa
	(1 MPa = 10 bar = 147 PSI)
Temperatura da água quente:	max. 60 °C
Temp. água quente recomendada:	42 °C
Desinfecção térmica:	max. 70 °C / 4 min

- Este produto foi única e exclusivamente concebido para água potável!

- As misturadoras não são compatíveis com o uso de esquentadores instantâneos hidráulicos, electrónicos ou térmicos.

Descrição do símbolo



Não utilizar silicone que contenha ácido acético!



Medidas (ver página 44)



Fluxograma (ver página 44)



Exemplos de montagem
(ver página 32)



Nesta zona é necessário um reforço na parede.



Meio da base de duche



Água quente



Água fria



Peças de substituição
(ver página 31)

XXX = Acabamentos

000 = Cromado

700 = Matt White



Acessórios especiais (ver página 31)
(não incluído no volume de fornecimento)



• Crescente 25 mm #13595000



• conjunto de nivelamento 1° #95521000



Limpeza (ver página 39)



Funcionamento (ver página 46)

Falha

Causa

Solução

Cabeça do chuveiro com fuga acentuada

- Cabeça do chuveiro suja / calcificada

- Limpar / descalcificar a cabeça do chuveiro





Wskazówki bezpieczeństwa

- △ Aby uniknąć zranień na skutek zgniecenia lub przecięcia, podczas montażu należy nosić rękawice ochronne.
- △ Ramię prysznica jest przystosowane do trzymania głowicy prysznica i nie może być obciążane innymi przedmiotami!
- △ Produkt może być używany tylko do kąpeli, higieny i czyszczenia ciała.

Wskazówki montażowe

- Przed montażem należy skontrolować produkt pod kątem szkód transportowych. Po montażu nie widać żadnych szkód transportowych ani szkód na powierzchni.
- Przewody i armatura muszą być montowane, płukane i kontrolowane według obowiązujących norm.
- Należy przestrzegać wytycznych instalacyjnych obowiązujących w danym kraju.
- Montaż produktu musi być wykonany przez wykwalifikowanego fachowca. Powierzchnia w miejscu montażu musi być równa (bez uskoków wzgl. wzajemnie przesuniętych płytek). Ściana w miejscu montażu musi być stabilna. Dokołone w komplecie śruby i kołki rozporowe są przeznaczone do betonu.
- Należy zamontować siłka łapaczy, aby zatrzymać zanieczyszczenia przedostające się z sieci instalacyjnej. Przedostające się zanieczyszczenia mogą mieć negatywny wpływ na działanie i/lub prowadzić do usterek w działaniu akcesoriów; za powstałe z tego tytułu szkody firma Hansgrohe nie ponosi odpowiedzialności.
- Produkt nie jest przewidziany do zastosowania w łaźni parowej!

Dane techniczne

Ciśnienie robocze: maks. 1 MPa
 Zalecane ciśnienie robocze: 0,17 - 0,4 MPa
 Ciśnienie próbne: 1,6 MPa
 (1 MPa = 10 bary = 147 PSI)

Temperatura wody gorącej: maks. 60°C
 Zalecana temperatura wody gorącej: 42°C
 Dezynfekcja termiczna: maks. 70°C / 4 min

- Produkt przeznaczony wyłącznie do wody pitnej!

- Armatura Hansgrohe może być wykorzystywana w połączeniu z hydraulicznie, elektronicznie i termicznie sterowanym ogrzewaczem przepływowym.

Opis symbolu



Nie stosować silikonów zawierających kwas octowy!



Wymiary (patrz strona 44)



Schemat przepływu
(patrz strona 44)



Przykłady montażowe
(patrz strona 32)



W tym obszarze konieczne jest wzmocnienie ściany.



Środek brodzika



Ciepła woda



Zimna woda



Części serwisowe (patrz strona 31)

XXX = Kody kolorów

000 = Chrom

700 = Matt White



Wyposażenie specjalne (patrz strona 31)

(Nie jest częścią dostawy)

- Przedłużka 25 mm #13595000

- zespół poziomujący 1° #95521000



Czyszczenie (patrz strona 39)



Obsługa (patrz strona 46)

Usterka

Barczo nieszczelny prysznic

Przyczyna

- Prysznic zanieczyszczony / pokryty kamieniem

Pomoc

- Oczyszczyć prysznic / usunąć z niego kamień





Bezpečnostní pokyny

- △ Pro zabránění řezným zraněním a pohmožděninám je nutné při montáži nosit rukavice.
- △ Držák sprchové hlavice je dimenzován pouze pro držení sprchové hlavice a nesmí se zatěžovat dalšími předměty!
- △ Produkt smí být používán pouze ke koupání a za účelem tělesné hygieny.

Pokyny k montáži

- Před montáží je třeba produkt zkontrolovat, zda nebyl při transportu poškozen. Po zabudování nebudou uznány žádné škody způsobené transportem nebo poškození povrchu.
- Vedení a armatura musí být namontovány, propláchnuty a otestovány podle platných norem.
- Je třeba dodržovat montážní pravidla platné v dané zemi.
- Při montáži produktu kvalifikovanou osobou je třeba dbát na to, aby byla upevňovací plocha v celé oblasti upevnění rovná (žádné vyčnívající spáry nebo zapuštění obkladů), aby struktura stěny byla vhodná pro montáž produktu a neměla žádná slabá místa.
- Sítka na zachytávání nečistot je třeba zabudovat, aby se zabránilo nečistotám vyplaveným z vodovodní sítě. Vyplavené nečistoty mohou ovlivnit funkci sprchy a / nebo mohou vést k poškození funkčních částí armatury. Na takto vzniknuté škody se záruka firmy Hansgrohe nevztahuje.
- Výrobek není určen k použití ve spojení s parní lázní!

Technické údaje

Provozní tlak:	max. 1 MPa
Doporučený provozní tlak:	0,17 - 0,4 MPa
Zkušební tlak:	1,6 MPa
	(1 MPa = 10 bar = 147 PSI)
Teplota horké vody:	max. 60 °C
Doporučená teplota horké vody:	42 °C
Tepelná dezinfekce:	max. 70 °C / 4 min

- Výrobky Hansgrohe jsou vhodné pro přímý kontakt s pitnou vodou.
- Tento produkt nemůže být používán ve spojení s hydraulicky a teplotně řízenými průtokovými ohřivači.

Popis symbolů

 Nepoužívat silikon s obsahem kyseliny octové!

 **Rozmíry** (viz strana 44)

 **Diagram průtoku** (viz strana 44)

 **Příklady montáže** (viz strana 32)

 V této oblasti je potřebné zesílení stěny.

 Sítěd sprchové vany

 Teplá voda

 Studená voda

 **Servisní díly** (viz strana 31)

XXX = Kód povrchové úpravy

000 = Chrom

700 = Matt White

 **Zvláštní příslušenství** (viz strana 31)
(není součástí dodávky)

• prodloužení 25 mm #13595000

• vyrovnávací sada 1° #95521000

 **Čištění** (viz strana 39)

 **Ovládání** (viz strana 46)

Porucha

Větší netěsnosti u hlavové sprchy

Příčina

- Znečištění / usazeniny vodního kamena na hlavové sprše

Odstanění

- Vyčistěte hlavovou sprchu / odstraňte vodní kámen





Bezpečnostné pokyny

- ⚠ Pri montáži musíte nosiť rukavice, aby ste predišli pomliaždeninám a rezným poraneniam.
- ⚠ Rameno držiaka hlavice sprchy je určené len na uchytienie hlavice sprchy a nesmie sa zaťažovať inými predmetmi!
- ⚠ Produkt sa smie používať len na kúpanie a telesnú hygienu.

Pokyny pre montáž

- Pred montážou musíte produkt skontrolovať, či nebol počas transportu poškodený. Po zabudovaní nebudú uznané žiadne škody spôsobené transportom alebo poškodenia povrchu.
- Ledningarna och blandaren måste monteras, spolás igenom och kontrolleras enligt de gällande normerna.
- Je potrebné dodržiavať smernice o inštalácii, ktoré sú práve teraz platné v krajinách.
- Pri montáži produktu kvalifikovanou osobou treba dávať pozor na to, aby bola upevňovacia plocha v celej oblasti upevnenia rovná (žiadne vyčnievajúce medzery alebo zapustenia obkladov), aby štruktúra steny bola vhodná pre montáž produktu a nemá žiadne slabé miesta.
- Sitká na zachytávanie nečistôt musíte zabudovať, aby ste zabránili nečistotám vyplaveným z vodovodnej siete. Vyplavené nečistoty môžu ovplyvniť funkciu sprchy a/alebo môžu viesť k poškodeniu funkčných častí armatúry. Na takto vzniknuté škody sa záruka firmy Hansgrohe nevzťahuje.
- Výrobok nie je vhodný na použitie v spojení s parným kúpeľom!

Technické údaje

Prevádzkový tlak:	max. 1 MPa
Doporučený prevádzkový tlak:	0,17 - 0,4 MPa
Skúšobný tlak:	1,6 MPa
	(1 MPa = 10 bar = 147 PSI)
Teplota teplej vody:	max. 60°C
Doporučená teplota teplej vody:	42°C
Termická dezinfekcia:	max. 70°C / 4 min

- Výrobok je koncipovaný výhradne pre pitnú vodu!
- Tento produkt sa nesmie používať v spojení s hydraulicky a teplotne riadenými prietokovými ohrievačmi.

Popis symbolov



Nepoužívať silikón s obsahom kyseliny octovej!



Rozmery (viď strana 44)



Diagram prietoku (viď strana 44)



Priklady montáže (viď strana 32)



V tejto oblasti je potrebné zosilnenie steny.



Stred sprchovej vane



Teplá voda



Studená voda



Servisné diely (viď strana 31)

XXX = Farebné označenie

000 = Chróm

700 = Matt White



Zvláštne príslušenstvo

(viď strana 31) (nie je súčasťou dodávky)



• Predĺženie 25 mm #13595000



• zarovnávací sada 1° #9521000



Čistenie (viď strana 39)



Obsluha (viď strana 46)

Porucha

Vrchná sprcha veľmi netesná

Príčina

- Vrchná sprcha znečistená / zavápnená

Pomoc

- Vyčistite / odvápnite vrchnú sprchu





安全技巧

- △ 装配时为避免挤压和切割受伤，必须戴上手套。
- △ 头顶花洒夹持杆只为夹持头顶花洒而设计，不得让其承载其它物品！
- △ 本产品只允许作为洗浴、卫生和洁身之用。

安装提示

- 安装前必须检查产品是否受到运输损害。安装后将不认可运输损害或表面损伤。
- 管道和阀门必须根据通用标准进行安装、冲洗和检查。
- 请遵守当地国家现行的安装规定。
- 由有资格的专业人员进行产品安装时请注意：在所有加固区域中，加固表面是否平整（无突出的接缝或瓷砖），墙体结构是否适合产品安装且未显露出任何缺点。
- 必须安装接污滤网，以免从管网中冲入污物。一旦污物冲入，将会有碍功能和/或导致阀门功能部件的损坏，由此而产生的各种损害汉斯格雅公司将不承担责任。
- 本产品并非设计来与蒸气浴连接使用！

技术参数

工作压力: 最大 1 MPa
 推荐工作压力: 0,17 - 0,4 MPa
 测试压强: 1,6 MPa
 (1 MPa = 10 bar = 147 PSI)

热水温度: 最大 60°C
 推荐热水温度: 42°C
 热力消毒: 最大 70°C / 4 分钟

- 该产品专为饮用水设计！
- 该产品不可与液控和热控即热式热水器连接使用。

符号说明

 请勿使用含有乙酸的硅胶！

 大小 (参见第页 44)

 流量示意图 (参见第页 44)

 安装示意 (参见第页 32)

 该区域需要一个加固边壁。

 中心淋浴盆

问题

花洒头严重泄露

原因

- 花洒头脏污/产生钙质垢

补救

- 清洁花洒头/去除钙质垢

 热水
 冷水

 备用零件 (参见第页 31)

XXX = 颜色代码

000 = 镀铬

700 = Matt White

 选装附件 (参见第页 31) (不在供货范围内)

• 加长 25 mm #13595000

• 调平装置 1° #95521000



清洗 (参见第页 39)

操作 (参见第页 46)



Указания по технике безопасности

- Во время монтажа следует надеть перчатки во избежание прищемления и порезов.
- Кронштейн верхнего душа предназначен только для подсоединения верхнего душа. Запрещается подвешивать на него другие предметы!
- Изделие разрешается использовать только в гигиенических целях: для принятия ванны и личной гигиены.

Указания по монтажу

- Перед монтажом следует проверить изделие на предмет повреждений при перевозке. После монтажа претензии о возмещении ущерба за повреждения при перевозке или повреждения поверхности не принимаются.
- Трубы и арматура должны быть установлены, промыты и проверены в соответствии с действующими нормами.
- Необходимо соблюдать требования по монтажу, действующие в соответствующих странах.
- Во время монтажа изделия квалифицированным персоналом поверхность крепления должна быть ровной по всей области крепления (не допускайте выступающих стыков или перекоса облицовочной плитки); для монтажа изделия следует использовать подходящую стену достаточной прочности.
- Для предотвращения попадания загрязнений из водопроводной сети необходимо устанавливать грязеуловители. Частицы грязи могут нарушить работу и/или привести к повреждению функциональных деталей арматуры. Компания Hansgrohe не несет ответственности за подобные повреждения.
- Изделие не предназначено для использования в паровой бане!

Технические данные

Рабочее давление: не более 1 МПа
 Рекомендуемое рабочее давление: 0,17 - 0,4 МПа
 Давление: 1,6 МПа
 (1 МПа = 10 bar = 147 PSI)
 Температура горячей воды: не более 60 °C
 Рекомендуемая темп. гор. воды: 42 °C
 Термическая дезинфекция: не более 70 °C / 4 мин

- Изделие предназначено исключительно для питьевой воды!
- Применение этой продукции при наличии гидравлических и проточных нагревателей с тепловой регулировкой не допускается.

Описание символов



Не применяйте силикон, содержащий уксусную кислоту.



Резьбы (см. стр. 44)



Схема потока (см. стр. 44)



Варианты установки (см. стр. 32)



В этой области требуется укрепление стены.



Середина душевой ванны



Теплая вода



Холодная вода



Комплект (см. стр. 31)

XXX = Цветная кодировка

000 = Хром

700 = Matt White



Специальные принадлежности (см. стр. 31)

(не включено в объем поставки!)



• Удлинение 25 мм #13595000



• комплект для выравнивания 1° #95521000



Очистка (см. стр. 39)



Эксплуатация (см. стр. 46)

Неисправность

Причина

Устранение неисправности

Сильная течь в душевой головке

- Душевая головка засорилась / покрылась известковым налетом

- Почистить душевую головку / удалить известковый налет





Turvallisuusohjeet

- △ Asennuksessa on käytettävä käsiineitä puristumien ja viiltojen aiheuttamien tapaturmien estämiseksi.
- △ Pääsuihkun varsi on tarkoitettu vain kannattamaan pääsuihkua. Sitä ei saa kuormittaa muilla esineillä!
- △ Tuotetta saa käyttää ainoastaan kylpy-, hygienia- ja puhdistustarkoituksiin.

Asennusohjeet

- Ennen asennusta on tarkastettava tuotteen mahdolliset kuljetusvahingot. Asennuksen jälkeen kuljetus- ja pintavaurioita ei hyväksytä.
- Putket ja hana on asennettava, huuhdeltava ja tarkastettava voimassa olevien standardien mukaisesti.
- Jokaisessa maassa on noudatettava siellä päteviä asennusohjeita.
- Pätevän ammattihenkilöstön asentaessa tuotetta on otettava huomioon, että kiinnityspinnan on oltava koko kiinnitysalueelta tasainen (ei korkeita saumoja tai laattojen yhtymäkohtia), seinän rakenne soveltuu tuotteen asennukseen eikä siinä ole heikkoja kohtia.
- Likasihdit on asennettava, jotta lian huuhtoutuminen vesijohdverkosta voidaan välttää. Huuhtoutuvat likahiukkaset voivat häiritä hanan toimintaa ja/tai vahingoittaa sen toimintaosia, Hansgrohe ei vastaa tästä aiheutuneista vahingoista.
- Tuotetta ei ole tarkoitettu käytettäväksi yhdessä höyrykyllyn kanssa!

Tekniset tiedot

Käyttöpaine:	maks. 1 MPa
Suosittelut käyttöpaine:	0,17 - 0,4 MPa
Koestuspaine:	1,6 MPa
	(1 MPa = 10 bar = 147 PSI)
Kuuman veden lämpötila:	maks. 60 °C
Kuuman veden suosituslämpötila:	42 °C
Lämpödesinfektio:	maks. 70 °C / 4 min

- Tuote on suunniteltu käytettäväksi ainoastaan juomaveden kanssa!
- Tätä tuotetta ei voi käyttää hydraulisesti tai termisesti ohjattujen läpivirtauskuumentimien yhteydessä.

Merkin kuvaus



Älä käytä etikkahappopitoista silikonia!



Mitat (katso sivu 44)

Virtausdiagrammi (katso sivu 44)



Asennusesimerkkejä (katso sivu 32)



Tässä kohdassa seinää on vahvistettava



Suihkualtaan keskusta



Lämmin vesi



Kylmä vesi



Varaosat (katso sivu 31)

XXX = Värikoodaus

000 = Kromi

700 = Matt White



Erytisvaruste (katso sivu 31)

(ei kuulu toimitukseen)

• Pidennys 25 mm #13595000

• suihkusaadin 1° #95521000



Puhdistus (katso sivu 39)



Käyttö (katso sivu 46)

Häiriö

Pääsuihku erittäin epätavits

Syy

- Pääsuihku likaantunut /kalkkeutunut - Pääsuihkun puhdistus / kalkinpoisto

Toimenpide





Säkerhetsanvisningar

- △ Handskar ska bäras under monteringsarbetet så att man kan undvika kläm- och skärskador.
- △ Armen som håller huvudduschen är bara konstruerad för detta; den får inte belastas med andra föremål!
- △ Produkten får bara användas till kroppshygien med bad och dusch.

Monteringsanvisningar

- Det måste undersökas om produkten har transportskador innan den monteras. Efter monteringen accepteras inga transport- eller ytskiktsskador.
- Ledningarna och blandaren måste monteras, spolats igenom och kontrolleras enligt de gällande normerna.
- De installationsriktlinjer som gäller i länderna ska följas.
- När kvalificerad fackpersonal monterar produkten är det viktigt att fästytan är plan över hela fastsättningsområdet (inga fogar som sticker ut eller kakelförskjutning) och att väggstrukturen är lämplig för en montering av produkten och inte har några svaga punkter.
- Smutsfiltren måste monteras så att inte smuts från ledningsnätet kan tränga in. Smuts som spolats in kan påverka funktionen och/eller leda till skador på funktionsdelar i armaturen. Hansgrohe fransäger sig allt ansvar för skador som kan härledas till detta.
- Produkten är inte avsedd att användas tillsammans med ett ångbad!

Tekniska data

Driftstryck:	max. 1 MPa
Rek. driftstryck:	0,17 - 0,4 MPa
Tryck vid provtryckning:	1,6 MPa
	(1 MPa = 10 bar = 147 PSI)
Varmvattentemperatur:	max. 60 °C
Rek. varmvattentemp.:	42 °C
Termisk desinfektion:	max. 70 °C / 4 min

- Produkten är enbart avsedd för dricksvatten!
- Denna produkt kan inte användas tillsammans med hydrauliskt och termiskt styrda varmvattenberedare.

Symbolförklaring



Använd inte silikon som innehåller ättiksyra!



Måtten (se sidan 44)



Flödesschema (se sidan 44)



Monteringsexempel (se sidan 32)



Šioje zonoje būtinas sienos sutvirtinimas



Mitten av duschkaret



Varmvatten



Kallvatten



Reservdelar (se sidan 31)

XXX = Färgkodning

000 = Krom

700 = Matt White



Specialtillbehör (se sidan 31)
(medföljer ej leveransen)

• Förlängning 25 mm #13595000

• Utjämningsset 1° #95521000



Rengöring (se sidan 39)



Hantering (se sidan 46)



Störning

Duschmunstycket mycket otätt

Orsak

- Duschmunstycket smutsigt/förkalkat

Åtgärd

- Rengör/avkalka duschmunstycket





Saugumo technikos nurodymai

- △ Apsaugai nuo užspaudimo ir įsijovimo montavimo metu mūvėkite pirštines.
- △ Dušo laikiklis skirtas tik dušo galvutei laikyti, todėl neturi būti apkraunamas kitokiais daiktais!
- △ Gaminys turi būti naudojamas tik maudymuisi, kūno higienai ir švarai palaikyti.

Montavimo instrukcija

- Prieš montuojant būtina patikrinti, ar gaminys nebuvo pažeistas transportavimo metu. Sumontavus pretenzijos dėl transportavimo ir paviršiaus pažeidimų nepriimamos.
- Vamzdžiai ir sujungimai turi būti montuojami, plaunami ir tikrinami pagal galiojančias normas.
- Laikykitės atitinkamoje šalyje galiojančių direktyvų dėl įrengimo.
- Atlikdami montavimo darbus, kvalifikuoti darbuotojai turi atkreipti dėmesį, kad pritvirtinimo plokštuma būtų lygi (be išsikišusių siūlių ar perkreiptų plytelių), sienų konstrukcija tiktų gaminiui montuoti ir neturėtų jokių trūkumų.
- Turu būti įmontuoti tinkliniai filtrai: jie apsaugo nuo kietųjų dalelių, kurios gali patekti iš vandentiekio. Kietosios dalelės gali sutrikdyti santechnikos jungčių darbą ir (arba) pakenkti jų funkcinėms dalims. „Hansgrohe“ neatsako už gedimus dėl neįmontuoto filtro.
- Gaminis nefinkamas naudoti garo pirtyje!

Techniniai duomenys

Darbinis slėgis: ne daugiau kaip 1 MPa
 Rekomenduojamas slėgis: 0,17 - 0,4 MPa
 Bandomasis slėgis: 1,6 MPa
 (1 MPa = 10 barų = 147 PSI)

Karšto vandens temperatūra: ne daugiau kaip 60°C
 Rekomenduojama karšto vandens temperatūra: 42°C
 Terminis dezinfekavimas: ne daugiau kaip 70°C / 4 min

- Produktas skirtas tik geriamajam vandeniui!
- Šio produkto negalima naudoti kartu su hidrauliškai ir termiškai valdomu tekančio vandens šildytuvu.

Simbolio aprašymas



Nenaudokite silikono, kurio sudėtyje yra acto rūgšties!



Įšmatavimai (žr. psl. 44)

Pralaidumo diagrama (žr. psl. 44)



Montavimo pavyzdžiai (žr. psl. 32)



Šioje zonoje būtinas sienos sutvirtinimas



Dušo padėklo centras



Šiltas vanduo



Šaltas vanduo



Atsarginės dalys (žr. psl. 31)

XXX = Spalvos

000 = Chrom

700 = Matt White



Specialūs priedai (žr. psl. 31)
 (nėra pridedama)

• Ilgiklis 25 mm #13595000

• lygio regulatorius 1° #95521000



Valymas (žr. psl. 39)



Eksploatacija (žr. psl. 46)

Gedimas

Labai nesandari dušo galva

Priežastis

- Užsiteršusi / užkalkėjusi dušo galva

Priemonė

- Išvalykite dušo galvą / pašalinkite iš jos kalkių nuosėdas





Sigurnosne upute

- △ Prilikom montaže se radi sprječavanja prignječenja i posjekotina moraju nositi rukavice.
- △ Nosač tuša iznad glave je dimenzioniran samo za držanje danog tuša i ne smije se opterećivati drugim predmetima!
- △ Proizvod se smije primjenjivati samo za kupanje, tuširanje i osobnu higijenu.

Upute za montažu

- Prije montaže mora se provjeriti je li proizvod oštećen prilikom transporta. Nakon ugradnje se ne priznaju nikakve reklamacije koje se odnose na površinska i transportna oštećenja.
- Cijevi i armatura moraju biti postavljeni, isprani i testirani prema važećim normama.
- Obvezno se moraju uvažiti propisi o instalacijama koji vrijede u dotičnoj zemlji.
- Kada proizvod montira kvalificirano stručno osoblje treba paziti da čitava površina na koju se učvršćuje bude ravna (bez istaknutih fuga ili krivljenja pločica), da je zidna konstrukcija primjerena montaži proizvoda te da nema slabih mjesta.
- Obvezno postavite mrežice za hvatanje prljavštine kako biste izbjegli prodiranje onečišćenja iz vodovoda. Prljavština može dovesti do djelomičnog ili potpunog oštećenja dijelova armature. Za eventualna oštećenja uzrokovana prljavštinom proizvođač Hansgrohe ne preuzima nikakvu odgovornost.
- Proizvod nije predviđen za primjenu u parnim kupalicama!

Tehnički podatci

Najveći dopušteni tlak:	tlak 1 MPa
Preporučeni tlak:	0,17 - 0,4 MPa
Probni tlak:	1,6 MPa
	(1 MPa = 10 bar = 147 PSI)
Temperatura vruće vode:	tlak 60°C
Preporučena temperatura vruće vode:	42°C
Termička dezinfekcija:	tlak 70°C / 4 min

- Proizvod je koncipiran isključivo za pitku vodu!
- Ovaj proizvod se ne može rabiti uz hidraulički i termički regulirane protočne bojlere.

Opis simbola



Nemojte koristiti silikon koji sadrži octenu kiselinu!



Mjere (pogledaj stranicu 44)



Dijagram protoka
(pogledaj stranicu 44)



Primjeri instalacija
(pogledaj stranicu 32)



U ovom je području potrebno ojačanje zida.



Sredina tuš-kada



Topla voda



Hladna voda



Rezervni dijelovi

(pogledaj stranicu 31)

XXX = Boje

000 = Krom

700 = Matt White



Posebni pribor (pogledaj stranicu 31)
(Nije sadržano u isporuci!)



• Produljenje 25 mm #13595000



• komplet za podešavanje 1° #95521000



Čišćenje (pogledaj stranicu 39)



Upotreba (pogledaj stranicu 46)

Greška

Tuš iznad glave jako propušta

Uzrok

- Tuš iznad glave je onečišćen / ima naslaga kamenca

Otklanjanje

- Očistite odnosno uklonite kamenac s tuša iznad glave





⚠ Güvenlik uyarıları

- ⚠ Montaj esnasında ezilme ve kesilme gibi yaralanmaları önlemek için eldiven kullanılmalıdır.
- ⚠ Başlıklı püskürtücü kolu yalnızca başlıklı püskürtücünün tutulması için tasarlanmıştır, başka nesnelere üzerine yük bindirilmemelidir!
- ⚠ Ürün yalnızca banyo, hijyen ve beden temizliği amaçları doğrultusunda kullanılabilir.

Montaj açıklamaları

- Montaj işleminden önce ürün nakliye hasarları yönünden kontrol edilmelidir. Montaj işleminden sonra nakliye veya yüzey hasarları için sorumluluk üstlenilmemektedir.
- Boruların ve armatürün montajı, yıkanması ve kontrolü geçerli normlara göre yapılmalıdır.
- Ülkelerde geçerli kurulum yönetmeliklerine riayet edilmelidir.
- Ürünün yetkili uzman personel tarafından montajı yapılırken, sabitleme yüzeyinin sabitleme planının tüm alanında bulunduğu (derz veya fayans kayması olmamalıdır), duvar yapısının ürünün montajı için uygun olduğuna ve zayıf noktaları bulunmadığına dikkat edilmelidir.
- Şebeke borusunda kir oluşumunu önlemek için kir toplama eleklerinin takılması gereklidir. Kirlenmeler işlevi olumsuz etkileyebilir ve/veya armatürün işlev parçalarında hasarlara yol açabilir. Hansgrohe, bundan dolayı kaynaklanabilecek hasarlara karşı sorumluluk üstlenmez.
- Ürün bir buhar banyosu ile bağlantılı olarak kullanım için öngörülmemiştir!

Teknik bilgiler

İşletme basıncı:	azami 1 MPa
Tavsiye edilen işletme basıncı:	0,17 - 0,4 MPa
Kontrol basıncı:	1,6 MPa
	(1 MPa = 10 bar = 147 PSI)
Sıcak su sıcaklığı:	azami 60°C
Tavsiye edilen su ısı:	42°C
Termik dezenfeksiyon:	azami 70°C / 4 dak

- Ürün sadece şebeke suyu için tasarlanmıştır!
- Bu ürün hidrolik ve termik kumandalı akış ısıtıcılarıyla bağlantılı olarak kullanılmamalıdır.

Simgeler açıklaması

Asetik asit içeren silikon kullanmayın!

Ölçüleri (bakınız sayfa 44)

Akış diyagramı (bakınız sayfa 44)

Montaj Örneği (bakınız sayfa 32)

Bu alanda duvarın kalınlaştırılması gereklidir.

Duş küvetinin ortası

Sıcak su

Soğuk su

Yedek Parçalar (bakınız sayfa 31)

XXX = Renkler

000 = Krom

700 = Matt White

Özel aksesuarlar (bakınız sayfa 31)
(Teslimat kapsamına dahil değildir)

• Uzatma 25 mm #13595000

• tesfiye ayarlı 1° #95521000

Temizleme (bakınız sayfa 39)

Kullanımı (bakınız sayfa 46)

arıza

Yağış duş başlığı çok sızdırıyor

sebebi

- Yağış duş başlığı kirli / kireçli

yardım

- Yağış duş başlığını temizleyin / kirecini temizleyin





Instrucțiuni de siguranță

- △ La montare utilizați mănuși pentru evitarea contuziunilor și tăierii mâinilor.
- △ Brațul parei de duș este destinat doar pentru a susține para, acesta nu poate fi prevăzut cu alte obiecte.
- △ Produsul poate fi utilizat doar pentru spălarea, menținerea igienei și curățarea corpului.

Instrucțiuni de montare

- Înainte de instalare verificați, dacă produsul prezintă deteriorări de transport. După instalare garanția nu acoperă deteriorările de transport și cele de suprafață.
- Conductele și bateriile trebuie montate, spălate și verificate conform normelor în vigoare.
- Respectați reglementările referitoare la instalare valabile în țara respectivă.
- La montarea produsului de către un personal calificat se va avea grijă ca suprafața de fixare să fie plană pe toată aria de fixare (fără proeminențe ale rosturilor sau îmbinări între plăcile de faianță) și ca structura peretelui să fie corespunzătoare pentru fixarea produsului, să nu prezinte locuri cu rezistență redusă.
- Sitele pentru reținerea impurităților trebuie montate pentru evitarea pătrunderii impurităților din rețeaua de alimentare. Impuritățile pătrunse pot influența funcționarea și/sau pot provoca deteriorarea părților funcționale ale armăturilor. Garanția Hansgrohe nu acoperă aceste daune.
- Produsul nu este prevăzut pentru a fi folosit în combinație cu o baie de aburi!

Date tehnice

Presiune de funcționare: max. 1 MPa
 Presiune de funcționare recomandată: 0,17 - 0,4 MPa
 Presiune de verificare: 1,6 MPa
 (1 MPa = 10 bar = 147 PSI)

Temperatura apei calde: max. 60°C
 Temperatura recomandată a apei calde: 42°C
 Dezinfecție termică: max. 70°C / 4 min

- Produsul este destinat exclusiv pentru apă potabilă.
- Acest produs nu poate fi utilizat în combinație cu boilere cu flux continuu hidraulice sau comandate termic.

Descrierea simbolurilor



Nu utilizați silikon cu conținut de acid acetic!



Dimensiuni (vezi pag. 44)



Diagrama de debit (vezi pag. 44)



Exemple de montare (vezi pag. 32)



În această zonă este nevoie de întărirea peretelui.



În mijlocul căzii de duș



Apă caldă



Apă rece



Piese de schimb (vezi pag. 31)

XXX = Coduri de culori
 000 = Crom
 700 = Matt White



Accesorii opționale (vezi pag. 31)
 (nu este inclus în setul livrat)

- Prelungitor 25 mm #13595000
- Set sortimente 1° #95521000



Curățare (vezi pag. 39)



Utilizare (vezi pag. 46)



Deranjament

Capul de duș prezintă scurgeri masive

Cauza

- Capul de duș este înfundat / calcifiat

Măsurile de remediere

- Curățați / decalificați capul de duș





Υπ δείξεις σφ λεί ς

- △ Για να αποφύγετε τραυματισμούς κατά τη συναρμολόγηση πρέπει να φοράτε γάντια.
- △ Ο βραχίονας του ντους κεφαλιού έχει μελετηθεί μόνο για να κρατά τo ντους κεφαλιού, δεν επιτρέπεται να φορτίζεται με άλλα αντικείμενα!
- △ Το προϊόν επιτρέπεται να χρησιμοποιείται μόνο σαν μέσο λουτρού, υγιεινής και καθαρισμού του σώματος.

Οδηγίες σ ν ρμ λόγησης

- Πριν τη συναρμολόγηση πρέπει να εξεταστεί το προϊόν για ζημιές μεταφοράς. Μετά την εγκατάσταση δεν αναγνωρίζονται ζημιές από τη μεταφορά ή επιφανειακές ζημιές.
- Οι σωλήνες και η μπαταρία πρέπει να τοποθετηθούν σύμφωνα με τα ισχύοντα πρότυπα, να τεθούν υπό πίεση και να δοκιμαστούν.
- Θα πρέπει να τηρούνται οι οδηγίες εγκατάστασης που ισχύουν σε κάθε κράτος.
- Κατά τη συναρμολόγηση του προϊόντος από ειδικό προσωπικό θα πρέπει να ελέγχεται με ιδιαίτερη προσοχή η επιφάνεια στερέωσης, αν είναι επίπεδη σε όλη της την επιφάνεια (δεν πρέπει να εξέχουν αρμοί ή πλακάκια), αν η υποδομή του τοίχου είναι κατάλληλη για τη στερέωση του προϊόντος και αν παρουσιάζει ασθενή σημεία.
- Οι σήτες συλλογής ρύπων πρέπει να τοποθετηθούν, για να αποφεύγονται ρύποι που προέρχονται από το δίκτυο ύδρευσης. Οι ρύποι από το δίκτυο ύδρευσης μπορούν να επηρεάσουν αρνητικά και/ ή να προξενήσουν ζημιά στα λειτουργικά τμήματα της μπαταρίας. Τέτοιου είδους ζημιές δεν καλύπτονται από την εγγύηση της Hansgrohe
- Το προϊόν δεν είναι κατάλληλο για χρήση σε ατμόλουτρο!

Τεχνικά Χ ρ κτηριστικά

Λειτουργία πίεσης:	έως 1 MPa
Συνιστώμενη λειτουργία πίεσης:	0,17 - 0,4 MPa
Πίεση ελέγχου:	1,6 MPa
	(1 MPa = 10 bar = 147 PSI)
Θερμοκρασία ζεστού νερού:	έως 60 °C
Συνιστώμενη θερμοκρασία ζεστού νερού:	42 °C
Θερμική απολύμανση:	έως 70 °C / 4 min

- Το προϊόν έχει σχεδιαστεί αποκλειστικά για πόσιμο νερό!
- Αυτό το προϊόν δεν μπορεί να χρησιμοποιηθεί σε συνδυασμό με υδραυλικούς και θερμικά ελεγχόμενους ταχυθερμοσίφωνες.

Περιγραφή σ μβόλων



Μην χρησιμοποιείτε σιλίκονη που περιέχει οξικό οξύ!



Δι στάσεις (βλ. Σελίδα 44)



Διάγρ μμ ρ ής (βλ. Σελίδα 44)



Π ρ δείγμ τ σ ν ρμ λόγησης
(βλ. Σελίδα 32)



Σε αυτήν την περιοχή είναι απαραίτητη μία ενίσχυση του τοίχου.



Μέσον της ντουσιέρας



Ζεστό νερό



Κρύο νερό



Αντ λλ κτικά (βλ. Σελίδα 31)

XXX = Χρώματα
000 = Επιχρωμιωμένο
700 = Matt White



Ειδικά ζεσ άρ (βλ. Σελίδα 31)

(δεν περιλαμβάνεται στον παραδοτέο εξοπλισμό)



• Επιμήκυνση 25 mm #13595000



• σετ οριζοντίωσης (αλφάδιασμα) 1° #95521000



Κ θ ρισμός (βλ. Σελίδα 39)



Χειρισμός (βλ. Σελίδα 46)

Βλάβη

Ντους κεφαλιού ιδιαίτερα μη στεγανό

Αιτί

- Ντους κεφαλιού ακάθαρμο / με άλατα

Διόρθωση

- Καθαρίστε το ντους κεφαλιού / αφαιρέστε τα άλατα





Varnostna opozorila

- △ Pri montaži je treba nositi rokavice, da se preprečijo poškodbe zaradi zmečkanja ali urezov.
- △ Nosilna roka naglavne prhe je konstruirana le za nošenje prhe in je ne smete obremeniti z drugimi predmeti!
- △ Ta izdelek se sme uporabljati le z namenom umivanja, vzdrževanja higiene in telesne nege.

Navodila za montažo

- Pred montažo je treba izdelek preveriti glede morebitnih transportnih poškodb. Po vgradnji transportne ali površinske poškodbe ne bodo več priznane.
- Cevi in armaturo je treba montirati, izprati in preveriti po veljavnih standardih.
- Upoštevati je treba pravilnike o inštalacijah, ki veljajo v posamezni državi.
- Pri montaži tega proizvoda s strani kvalificiranega strokovnega osebja je treba paziti na to, da je pritrdilna ploskev na celotni površini za pritrditiv gladka (brez izstopajočih fug ali zasekov ploščic), da je struktura stene primerna za montažo proizvoda in ne kaže šibkih mest.
- Vgraditei je treba lovilnike umazanije, da se prepreči naplakanje umazanije iz vodovodne napeljave. Naplake umazanije lahko ogrozijo delovanje in/ali povzročijo okvare na funkcionalnih delih armature. Za tako nastalo škodo podjetje Hansgrohe ne odgovarja.
- Proizvod ni predviden za uporabo v povezavi s parno kopeljo!

Tehnični podatki

Delovni tlak:	maks. 1 MPa
Priporočeni delovni tlak:	0,17 - 0,4 MPa
Preskusni tlak:	1,6 MPa
	(1 MPa = 10 bar = 147 PSI)
Temperatura tople vode:	maks. 60 °C
Priporočena temperatura tople vode:	42 °C
Termična dezinfekcija:	maks. 70 °C / 4 min

- Proizvod je zasnovan izključno za sanitarno vodo!
- Tega proizvoda ni možno uporabiti v povezavi s hidravlično in termično krmiljenimi pretočnimi grelniki.

Opis simbola



Ne smete uporabiti silikona, ki vsebuje osetno kislino!



Mere (glejte stran 44)



Diagram pretoka (glejte stran 44)



Primeri montaže (glejte stran 32)



V tem območju je potrebno ojačanje stene.



Sredina pršne kadi



Topla voda



Mrzla voda



Rezervni deli (glejte stran 31)

XXX = Barve
000 = Krom
700 = Matt White



Poseben pribor (glejte stran 31)
(Ni vključeno)

- Podaljšek 25 mm #13595000
- Izravnalni komplet 1° #95521000



Čiščenje (glejte stran 39)



Upravljanje (glejte stran 46)



Napaka

Prha zelo netesna

Vzrok

- Prha umazana / poapnena

Pomoč

- Prho očistite / odstranite apnenec



Ohutusjuhised

- △ Kandke paigaldamisel muljumis- ja löikevigastuste vältimiseks kindaid.
- △ Dušipea hoidik on mõeldud ainult dušipea hoidmiseks ja seda ei tohi muude esemetega koormata!
- △ Toodet tohib kasutada ainult pesemis-, hügieeni- ja kehapihustamisesmärkidel.

Paigaldamisjuhised

- Enne paigaldamist tuleb toodet kontrollida transpordikahjustuste osas. Pärast paigaldamist ei tunnustata enam transpordi- või pinnakahjustuste kaebuseid.
- Voolikute ja segisti paigaldamisel, loputamisel ja kontrollimisel tuleb lähtuda kehtivatest normatiividest
- Vastavas riigis kehtivaid paigalduseeskirju tuleb järgida.
- Toote paigaldamisel kvalifitseeritud spetsialistide poolt tuleb jälgida, et kinnituspind oleks kogu ulatuses ühtlaselt tasane (mitte ühtki üleseisvat vuuki või kaldus kahhelkivi), seina ülesehitus toote paigaldamiseks sobiv ja ilma nõrkade kohtadeta.
- Mustusesöölad tuleb paigaldada selleks, et eemaldada veevõrgust tulevaid mustuseosakesi. Mustuseosakesed võivad tööd segada ja/või armatuuri kahjustada, sellest tulenevate kahjude eest Hansgrohe ei vastuta.
- Toode ei sobi kasutamiseks aurusaunas!

Tehnilised andmed

Töörõhk maks. 1 MPa
 Soovitav töörõhk: 0,17 - 0,4 MPa
 Kontrollsurve: 1,6 MPa
 (1 MPa = 10 baari = 147 PSI)

Kuuma vee temperatuur: maks. 60 °C
 Soovitav kuuma vee temperatuur: 42 °C
 Termiline desinfitatsioon: maks. 70 °C / 4 min

- Toode on ette nähtud eranditult joogivee jaoks!
- Seda toodet ei saa kasutada koos hüdrauliliselt ja termiliselt juhitava läbivoolusoojendiga.

Sümbolite kirjeldus



Ärge kasutage äädikhapet sisaldavat silikooni!



Mõõtude (vt lk 44)



Läbivooludiagramm (vt lk 44)



Paigalduse näited (vt lk 32)

Selles alas tuleb seina tugevdada.



Dušivanni kese



Soe vesi



Külm vesi



Varuosad (vt lk 31)

XXX = Värvid

000 = Kroom

700 = Matt White



Spetsiaalne lisavarustus (vt lk 31)

(ei sisaldu komplektis)

• pikendus 25 mm #13595000

• tasanduskomplekt 1° #95521000



Puhastamine (vt lk 39)



Kasutamine (vt lk 46)

Rike

Vihmadušš lekitab tugevalt

Põhjus

- Vihmadušš määrduš/katlakivine

Lahendus

- Puhastada vihmadušš/eemaldada katlakivi





Drošības norādes

- △ Montāžas laikā, lai izvairītos no saspiedumiem un iegriezumiem, nepieciešams nēsāt cimdus.
- △ Galvas dušas statīvs paredzēts vienīgi galvas dušas atbilstīgai, to nedrīkst noslogot ar citiem priekšmetiem!
- △ Šo produktu drīkst izmantot tikai, lai mazgātos, higiēnai un ķermeņa tīrīšanai.

Norādījumi montāžai

- Pirms montāžas nepieciešams pārbaudīt, vai produktam transportēšanas laikā nav radušies bojājumi. Pēc iebūvēšanas bojājumi, kas radušies transportēšanas laikā, vai virsmas bojājumi netiek atzīti.
- Cauruļvadi un armatūra ir jāuzstāda, jāizskalo un jāpārbauda saskaņā ar spēkā esošajiem standartiem.
- Jāievēro attiecīgās valstīs spēkā esošās montāžas prasības.
- Kvalificētiem speciālistiem, montējot produktu, jāpiegriež vērība tam, lai piestiprināšanas virsma visā piestiprināšanas zonā ir gluda (nav fūgu vai flīžu iecirtumu), sienas uzbūve ir piemērota produkta montāžai un tajā nav nestabilu vietu.
- Nepieciešams iemontēt neīrurumu aizturēšanas filtrus, lai novērstu neīrurumu ieplūšanu no ūdensvada. Ieskalotie neīrurumi var traucēt armatūras darbību un / vai arī izraisīt rokas dušas daļu bojājumus, par kuriem Hansgrohe nenes atbildību.
- Produkts nav paredzēts lietošanai kopā ar tvaika vannu!

Tehniskie dati

Darba spiediens: maks. 1 MPa
 Ieteicamais darba spiediens: 0,17 - 0,4 MPa
 Pārbaudes spiediens: 1,6 MPa
 (1 MPa = 10 bar = 147 PSI)

Karstā ūdens temperatūra: maks. 60°C
 Ieteicamā karstā ūdens temperatūra: 42°C
 Termiskā dezinfekcija: maks. 70°C / 4 min

- Izstrādājums ir paredzēts tikai dzeramajam ūdenim!
- Šo izstrādājumu nevar uzstādīt kopā ar hidrauliski un termiski vadītu caurplūdes sildītāju.

Simbolu nozīme



Neizmantojot silikonu, kas satur etiķskābi!



Izmērus (skat. lpp. 44)



Caurplūdes diagramma
(skat. lpp. 44)



Montāžas piemēri (skat. lpp. 32)



Šajā zonā ir nepieciešams pastiprināt sienu.



Dušas paliktņa vidus



Siltais ūdens



Aukstais ūdens



Rezerves daļas (skat. lpp. 31)

XXX = Krāsu kodi
 000 = Hroma
 700 = Matt White



Speciāli aksesuāri (skat. lpp. 31)
(komplektā netiek piegādāts)



• Pagarinājums 25 mm #13595000



• nolīdzināšanas komplekts 1° #95521000



Tīrīšana (skat. lpp. 39)



Lietošana (skat. lpp. 46)

Traucējums

Stipra sūce dušas galvā

Iemesls

- Dušas galva netīra / pārkaļķojusies

Bojājumu novēršana

- Noņemt neīrurumus / kaļķus





Sigurnosne napomene

- △ Prilikom montaže se radi sprečavanja prignječenja i posekotina moraju nositi rukavice.
- △ Nosač tuša iznad glave je dimenzioniran samo za držanje datog tuša i ne sme se opterećivati drugim predmetima!
- △ Proizvod sme da se koristi samo za kupanje, tuširanje i ličnu higijenu.

Instrukcije za montažu

- Pre montaže se mora proveriti da li je proizvod oštećen pri transportu. Nakon ugradnje se ne priznaju nikakve reklamacije koje se odnose na površinska i transportna oštećenja.
- Vodovi i armatura moraju biti postavljeni, isprani i testirani prema važećim normama.
- Treba se pridržavati propisa koji u određenim zemljama važe za instalacije.
- Kada proizvod montira kvalifikovano stručno osoblje treba paziti da čitava površina na koju se učvršćuje bude ravna (bez istaknutih fuga ili krivljenja pločica), da je zidna konstrukcija primerena montaži proizvoda i da nema slabih mesta.
- Obavezno ugradite mrežice za hvatanje prljavštine, čime sprečavate ulazak prljavštine iz vodovoda. Prljavština može dovesti do delimičnog ili potpunog oštećenja delova armature. Za eventualna oštećenja prouzrokovana prljavštinom proizvođač Hansgrohe nije odgovoran.
- Proizvod nije predviđen za upotrebu u parnim kupatilima!

Tehnički podaci

Radni pritisak:	maks. 1 MPa
Preporučeni radni pritisak:	0,17 - 0,4 MPa
Probni pritisak:	1,6 MPa
	(1 MPa = 10 bar = 147 PSI)
Temperatura vruće vode:	maks. 60 °C
Preporučena temperatura vruće vode:	42 °C
Termička dezinfekcija:	maks. 70 °C / 4 min

- Proizvod je koncipiran isključivo za pijaću vodu!
- Ovaj proizvod se ne može koristiti uz hidraulički i termički regulisane protočne bojlere.

Opis simbola



Nemojte koristiti silikon koji sadrži sirćetnu kiselinu!



Mere (vidi stranu 44)



Dijagram protoka (vidi stranu 44)



Primeri montaže (vidi stranu 32)



U ovoj oblasti je potrebno ojačanje zida.



Sredina tuš-kada



Topla voda



Hladna voda



Rezervni delovi (vidi stranu 31)

XXX = Oznake boja

000 = Hrom

700 = Matt White



Poseban pribor (vidi stranu 31)

(Nije sadržano u isporuci)



• Produžetak 25 mm #13595000



• set za nivelisanje 1° #95521000



Čišćenje (vidi stranu 39)



Rukovanje (vidi stranu 46)

Smetnja

Tuš iznad glave jako propušta

Uzrok

- Tuš iznad glave je prljav ili obložen naslagama kamenca

Pomoć

- Očistite tuš iznad glave odnosno uklonite kamenac





Sikkerhetshenvisninger

- △ Bruk hansker under montasjen for å unngå klem- og kuttskader.
- △ Armen til hodedusjen er kun laget for å holde hodedusjen. Den må ikke belastes med andre gjenstander!
- △ Produktet skal kun brukes for bade-, hygiene- og kroppshygiene.

Montagehenvisninger

- Før montasjen skal produktet sjekkes for transportskader. Etter monteringen aksepteres ikke noen transport- eller overflateskader.
- Ledningene og armaturen skal monteres, spyles og sjekkes iht. de gyldige normer.
- Gjeldende retningslinjer for rørleggerarbeid i de enkelte land skal følges.
- Under monteringen av produktet gjort av kvalifisert fagpersonell, skal man påse at monteringsoverflaten på hele festeområdet er plant (ingen utstikkende fuger eller flisekanter), at veggoppbyggingen egner seg for produktmontasjen og ikke viser svake punkter.
- Smussiler skal bygges inn for å forhindre at smuss spyles inn fra ledningsnett. Innspylt smuss kan påvirke funksjonen negativt og/eller kan medføre skader på funksjonsdeler til armaturer. Hansgrohe påtar seg inget ansvar for skader som resulteres av dette.
- Produktet er ikke påtenkt for bruk sammen med et dampbad!

Tekniske data

Driftstrykk	maks. 1 MPa
Anbefalt driftstrykk:	0,17 - 0,4 MPa
Prøvetrykk	1,6 MPa
	(1 MPa = 10 bar = 147 PSI)
Varmtvannstemperatur	maks. 60 °C
Anbefalt temperatur for varmt vann	42 °C
Termisk desinfisering:	maks. 70 °C / 4 min

- Produktet er utelukkende designet for drikkevann!
- Dette produktet kan ikke brukes i forbindelse med hydraulisk og termisk styrte gjennomstrømningsovner.

Symbolbeskrivelse



Ikke bruk silikon som inneholder eddiksyre!

Feil

Dusjhode meget utett

Årsak

- Dusjhode tilsmusset/forkalket

Feilrettelse

- Rengjør/kalkrens dusjhodet



Mål (se side 44)



Gjennomstrømningsdiagram
(se side 44)



Montasje-eksempel (se side 32)



I dette området skal veggene forsterkes.



Midten på dusjkar



Varmtvann



Kaldtvann



Serviceledere (se side 31)

XXX = Fargekode

000 = Krom

700 = Matt White



Ekstratilbehør (se side 31)

(ikke med i leveransen)

• Forlengelse 25 mm #13595000

• Utligningssett 1° #95521000



Rengjøring (se side 39)



Betjening (se side 46)





Ук з ния з безоп сност

- △ При монтажа трябва да се носят ръкавици, за да се избегнат наранявания поради притискане или порязване.
- △ Рамото на разпръскателя за главата е разработена само, за да държи разпръскателя за главата, то не бива да се натоварва с други предмети!
- △ Позволено е използването на продукта само за къпане, хигиена и цели на почистване на тялото.

Ук з ния з монт ж

- Преди монтажа продуктът трябва да се провери за транспортни щети. След монтажа не се признават транспортни или повърхностни щети.
- Тръбопроводите и арматурата трябва да се монтират, промият и проверят в съответствие с валидните норми.
- Трябва да бъдат спазвани валидните в съответните страни предписания за инсталиране.
- При монтаж на продукта от квалифицирани специалисти да се внимава за това, закрепващата повърхност в целия диапазон на закрепването да бъде равна (без изпъкнали fugи или изместване на плочки), конструкцията на стената да е подходяща за монтаж на продукта и да няма слаби места.
- Трябва да се монтират цедките за улавяне на замърсяванията, за да се избегне натрупването на замърсявания от водопроводната мрежа. Натрупването на замърсявания може да наруши функцията и/или да доведе до увреждания на функционалните части на арматурата, Hansgrohe не носи отговорност за получените се по този начин щети
- Продуктът не е предвиден за употреба във връзка с парна баня!

Технически д нни

Работно налягане: макс. 1 МПа
 Препоръчително работно налягане: 0,17 - 0,4 МПа
 Контролно налягане: 1,6 МПа
 (1 МПа = 10 bar = 147 PSI)
 Температура на горещата вода: макс. 60 °C
 Препоръчителна температура на горещата вода:
 42 °C
 Термична дезинфекция: макс. 70 °C / 4 мин

- Продуктът е разработен само за питейна вода!
- Този продукт не може да се използва във връзка с хидравлично и термично управляеми проточни нагреватели.

Опис ние н символите



Не използвайте силикон, съдържащ оцветна киселина!



Р змери (вижте стр. 44)



Ди гр м н поток
(вижте стр. 44)



Примери з монт ж (вижте стр. 32)



В тази област е необходимо подсилване на стената.



Среда на коритото на душ-кабината



Топла вода



Студена вода



Сервизни ч сти (вижте стр. 31)

XXX = Цветово кодиране

000 = Хром

700 = Matt White



Специ лни прин длежности
(вижте стр. 31) (не се съдържа в обема на доставка)

• Удължител 25 мм #13595000

• изравняваща система 1° #95521000



Почиств не (вижте стр. 39)



Обслужв не (вижте стр. 46)



Неизпр вност

Причин

Помощ

Разпръскателят за главата е силно уплътнен - Разпръскател за главата замърсен / покрит с варовик - Почистете / освободете от варовик разпръскателя за главата





Udhëzime sigurie

- △ Për të evituar lëndimet e pickimeve ose të prerjeve gjatë procesit të montimit duhet që të vishni doreza.
- △ Mbjajtësja e kokës së dushit është projektuar vetëm për mbajtjen e kokës së dushit dhe nuk duhet që të rëndohet me objekte të tjera!
- △ Produkti duhet të përdoret vetëm qëllimet e banjave, të higjienës dhe të larjes së trupit.

Udhëzime për montimin

- Përpara montimit duhet që produkti të kontrollohet për dëmtime nga transporti. Pas instalimit nuk do të njihet asnjë dëmtim nga transporti ose dëmtim i sipërfaqes.
- Tubacionet dhe rubinetet duhet që të montohen, të shpëlahen dhe të kontrollohen sipas standardeve në fuqi
- Duhet të respektohen linjat udhëzuese të instalimit, të vlefshme për vendet respektive.
- Gjatë montimit të produktit nga teknikët e specializuar duhet mbajtur parasysh që sipërfaqja e montimit gjendet brenda zonës së përgjithshme të planit të montimit (nuk ka vendbashkime të dala ose mospërputhje të pllakave), që struktura e murit është e përshtatshme për montimin e produktit dhe që nuk paraqet asnjë pikë të dobët.
- Filtri i bllokimit të papastërtive duhet të instalohet për të parandaluar futjen e papastërtive nga rrjeti i tubacioneve të ujit. Futja e papastërtive mund të ndikojë në funksionimin dhe/ose mund të çojë në dëmtime të pjesëve funksionuese të rubinetit, dëmtime për të cilat Hansgrohe nuk mban asnjë përgjegjësi.
- Pajisja nuk është parashikuar për përdorim në lidhje me një banjë me avull!

Të dhëna teknike

Presioni gjatë punës	maks. 1 MPa
Presioni i rekomanduar:	0,17 - 0,4 MPa
Presioni për provë:	1,6 MPa
	(1 MPa = 10 bar = 147 PSI)
Temperatura e ujit të ngrohtë	maks. 60 °C
Temperatura e rekomanduar e ujit të ngrohtë:	42 °C
Dezinfektim Termik:	maks. 70 °C / 4 min

- Produkti është projektuar ekskluzivisht për ujë të pijshëm!

- Ky produkt nuk mund të përdoren me ngrohës elektrikë të ujit të drejtuara në mënyrë hidraulike ose termike.

Përshkrimi i simbolit



Mos përdorni silikon që në përbërje ka acid acetik.



Përmasat (shih faqen 44)



Diagrami i qarkullimit

(shih faqen 44)



Shembuj të montimit (shih faqen 32)



Në këtë zonë është i nevojshëm një përforcim i murit.



Mesi i vaskës së dushit



Uji i ngrohtë



Uji i ftohtë



Pjesët e servisit (shih faqen 31)

XXX = Kodimi me anë të ngjyrave

000 = Krom

700 = Matt White



Pajisje të posaçme (shih faqen 31)

(nuk përfshihet në vëllimin e furnizimit)



• Zgjatësi 25 mm #13595000



• set i nivelimit 1° #95521000



Pastrimi (shih faqen 39)



Përdorimi (shih faqen 46)

Dëmtim

Koka e dushit rrjedh shumë

Shkaku

- Koka e dushit e ndotur / me kalk

Ndihme

- Pastrimi / heqja e kalkut nga koka e dushit





تنبيهات الأمان ⚠️

⚠️ يجب ارتداء قفازات لليد أثناء التركيب لتجنب حدوث أخطار الإنحشار أو الجروح.

⚠️ وظيفة ذراع دش الرأس هي فقط الإمساك بدش الرأس، ولذلك يجب عدم التحميل عليه بأشياء أخرى.

⚠️ لا يجب استخدام المنتج إلا في أغراض الاستحمام والأغراض الصحية وأغراض تنظيف الجسم.

تعليمات التركيب

- قبل القيام بعملية التركيب، يجب فحص المنتج للتأكد من خلوّه من أية تلفيات ناتجة عن النقل. بعد القيام بعملية التركيب، لن يتم الاعتراف بوجود أية تلفيات سطحية أو تلفيات ناتجة عن عملية النقل.
- يجب تركيب وغسيل واختبار التوصيلات وخلطات المياه طبقاً للمعايير السارية.

• يجب مراعاة القواعد الخاصة بالتركيب وأعمال السباكة وفقاً للوائح الخاصة بكل بلد.

- عند التركيب بواسطة عمال تركيب متخصصين يجب الانتباه إلى أن مساحة التثبيت في مكان التركيب بوجه عام مسطحة (لا توجد روابط أو فروق للربط بين البلاطات). لذا يجب التأكد من أن الحائط الذي سيتم تركيب المنتج عليه صالح لذلك وأنه لا يوجد به نقاط ضعف.

• يتعين تركيب شبكة تجميع الأوساخ من أجل تفادي خروج الأوساخ الواردة من شبكة المواسير. قد تتسبب الأوساخ الواردة في حدوث أعطال أو تلف أجزاء من الوحدة أو كليهما. وبالتالي، فإن هانز جروه لا تتحمل مسئولية هذه الأعطال.

• لا يستخدم المنتج مع حمام بخار!

المواصفات الفنية

ضغط التشغيل: الحد الأقصى 1 ميجاباسكال
ضغط التشغيل الموصى به: 0,17 - 0,4 ميجاباسكال
ضغط الاختبار: 1,6 ميجاباسكال

(1 ميجاباسكال = 10 بار = PSI 147)
درجة حرارة الماء الساخن: الحد الأقصى 60°C
درجة الحرارة الموصى بها للماء الساخن: 42°C
تقييم حراري: الحد الأقصى 70°C / 4 الدقيقة

- المنتج مخصص فقط لماء الشرب!
- لا يمكن إستعمال هذا المنتج مع سخانات الماء الفورية الهيدروليكية أو الحرارية.

وصف الرمز

هام! لا تستخدم السليكون الذي يحتوي على أمضاض! 

أبعاد (راجع صفحة 44) 

رسم للصرف (راجع صفحة 44) 

مثال على التركيب (راجع صفحة 32) 

يلزم هذا في النطاق وجود تقوية للحائط.

بانيو مزود بدش في المنتصف 

ماء دافئ 

ماء بارد 

قطع الغيار (راجع صفحة 31) 

الألوان = XXX

كروم = 000

Matt White = 700

ملحقات خاصة (راجع صفحة 31) 

(غير مدرج مع المحتويات المسلمة)

• وصلة إطالة 25 مم #13595000 

• عدة التسوية 1° #95521000 

التنظيف (راجع صفحة 39) 

التشغيل (راجع صفحة 46) 

العلاج والإصلاح

- قم بتنظيف / التخلص من الجير برأس الدش

السبب

- رأس الدش متسخة / بها جير

العطل

رأس الدش ينفث بشكل واضح.

 التركيب (راجع صفحة 36)



Biztonsági utasítások

- △ A szerelésnél a zúzódások és vágási sérülések elkerülése érdekében kesztyűt kell viselni.
- △ A zuhanyfej karja csak a zuhanyfej tartására alkalmas, és nem szabad más tárgyakkal megterhelni!
- △ A terméket csak fürdéshez, mosakodáshoz, és egészségügyi tisztálkodáshoz szabad használni.

Szerelési utasítások

- A szerelés előtt ellenőrizni kell, hogy a terméknek nincs-e szállítási sérülése. Beépítés után a szállítási-vagy felületi sérüléseket nem ismerik el.
- A vezetékeket és a csaptelepet az érvényes szabványoknak megfelelően kell felszerelni, öblíteni és ellenőrizni
- Az egyes országokban érvényes installációs irányelveket be kell tartani.
- A termék képzett szakember általi felszerelése esetén ügyelni kell arra, hogy a rögzítési felület teljesen sima legyen (ne legyen kiálló fuga vagy csempe), a fal szerkezete a termék felszerelésére alkalmas legyen, és ne legyen gyenge pontja.
- A szűrőtömítéseket be kell szerelni a vízhálózatból származó szennyeződések kiküszöbölésére. A beáramló szennyeződések akadályozhatják és / vagy teljesen tönkre is tehetik a csaptelep funkcióit. Az ezekből adódó károkért a Hansgrohe nem felel.
- A terméket nem gőzfürdővel együttes használatra tervezték!

Műszaki adatok

Üzemi nyomás:	max. 1 MPa
Ajánlott üzemi nyomás:	0,17 - 0,4 MPa
Nyomáspróba:	1,6 MPa
	(1 MPa = 10 bar = 147 PSI)
Forróvíz hőmérséklet:	max. 60°C
Forróvíz javasolt hőmérséklete:	42°C
Termikus fertőtlenítés:	max. 70°C / 4 perc

- A terméket kizárólag ivóvízhez tervezték!
- Ha a zuhany működik, akkor ennek a zuhanykarral együtt kb. 10 kg a tömege. Ezért csak a falnak megfelelő rögzítő anyagot szabad használni! A mellékelt csavarok és tiplik csak tömör falakhoz használhatók.

Szimbólumok leírása



Ne használjon ecetsavtartalmú szilikon!



Méretet (lásd a oldalon 44)



Átfolyási diagramm
(lásd a oldalon 44)



Szerelési példák (lásd a oldalon 32)



Ezen a területen a fal megerősítésére van szükség.



Zuhanytálca közepe



Melegvíz



Hidegvíz



Tartozékok (lásd a oldalon 31)

XXX = Színkódolás
 000 = Króm
 700 = Matt White



Egyéb tartozék (lásd a oldalon 31)
(a szállítási egység nem tartalmazza)



• Hosszabbítás 25 mm #13595000



• szintező készlet 1° #95521000



Tisztítás (lásd a oldalon 39)



Használat (lásd a oldalon 46)

Hiba

A fejuhany erősen szivárog

Ok

- A fejuhany szennyezett / vízköves

Megoldás

- A fejuhanyt kitisztítani / vízkőtele-
níteni





Rainfinity 360 3jet

26234XXX

Rainfinity 250 3jet

26232XXX

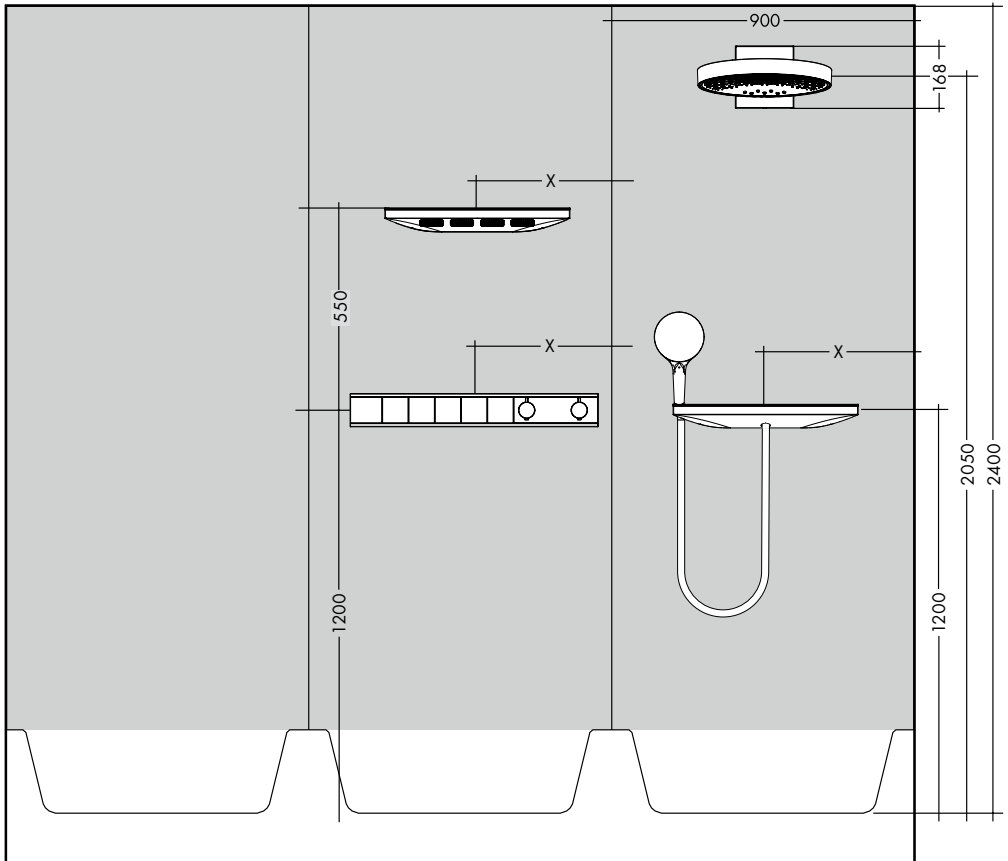

① PowderRain

② Intense PowderRain

③ RainStream

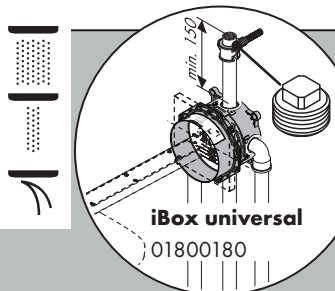

26243XXX

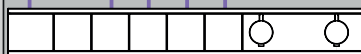

**15313180 +
15384XXX**



DN 20
(3/4")

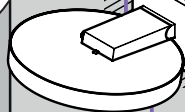

①
②
③

DN 15
(1/2")

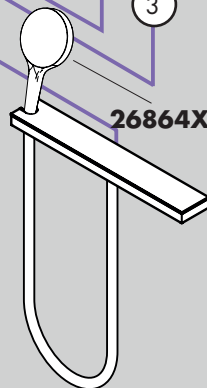

26864XXX



Rainfinity 360 3jet

26234XXX

Rainfinity 250 3jet

26232XXX

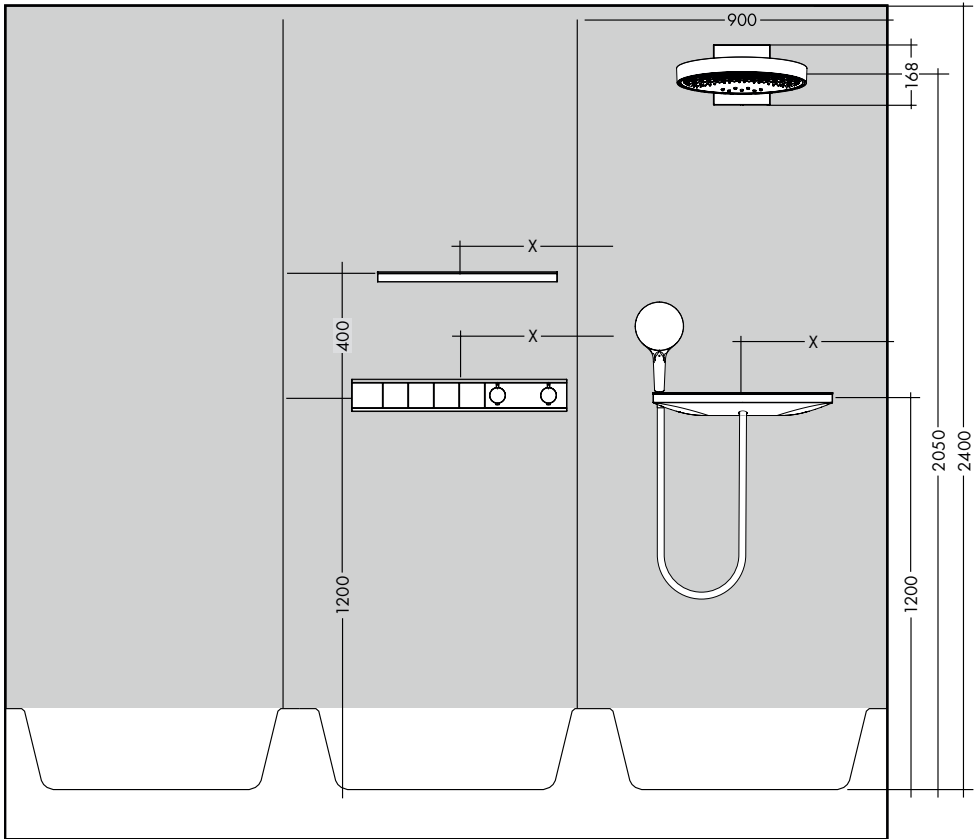

① PowderRain

② Intense PowderRain

③ RainStream

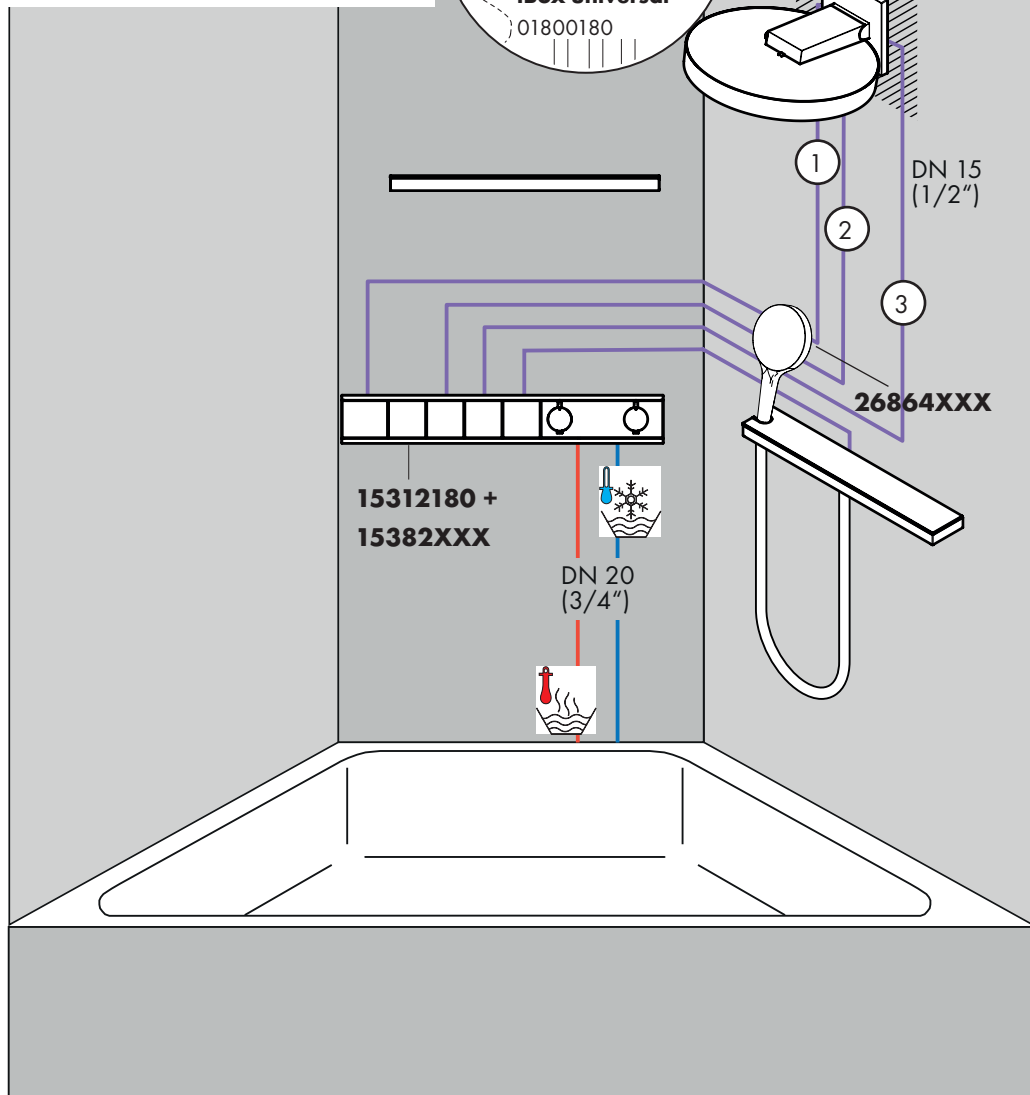
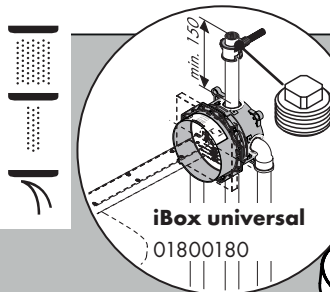



iBox universal
01800180

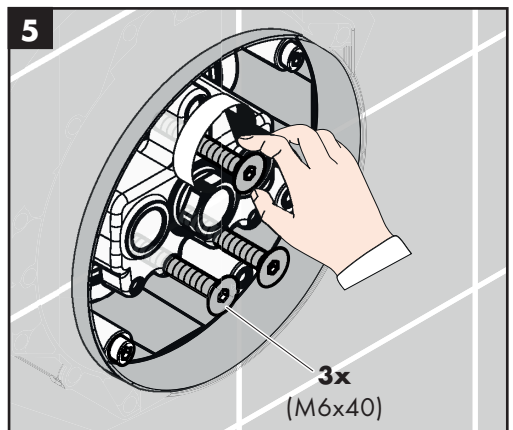
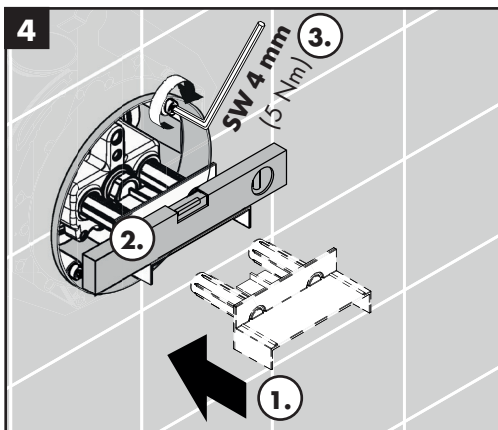
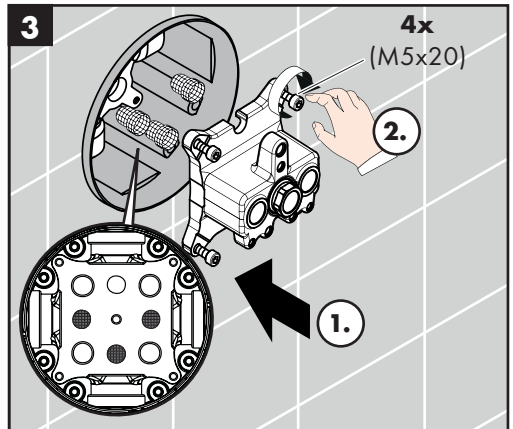
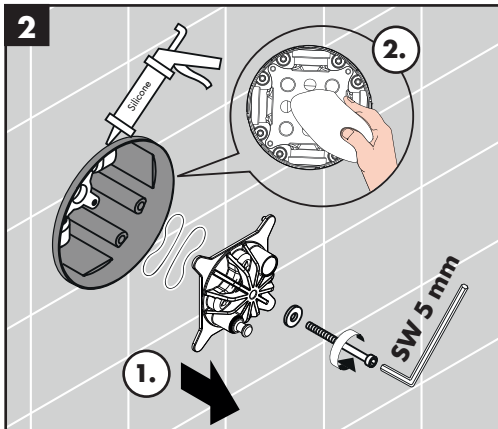
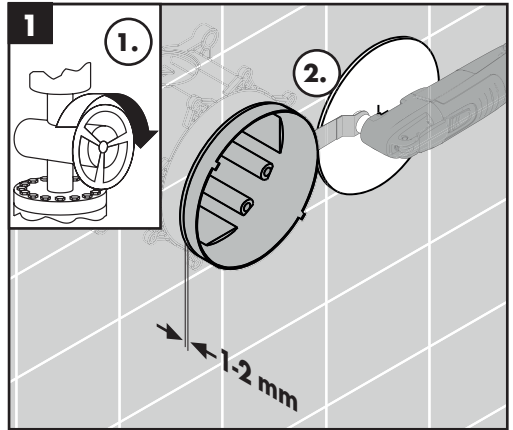
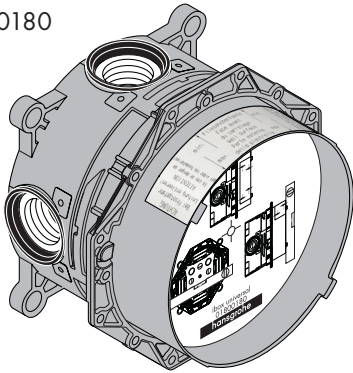

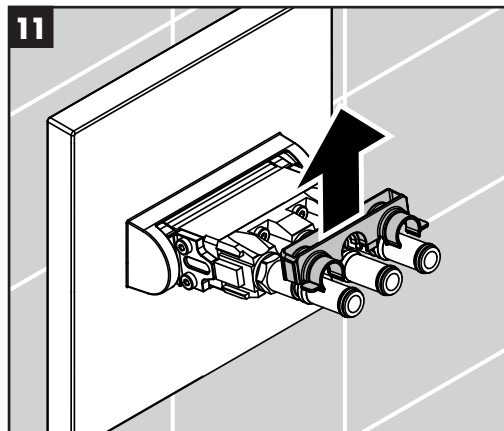
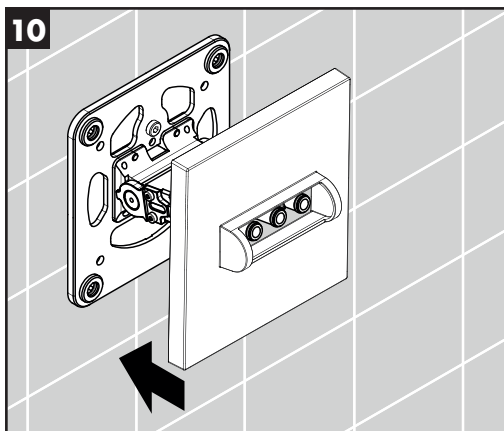
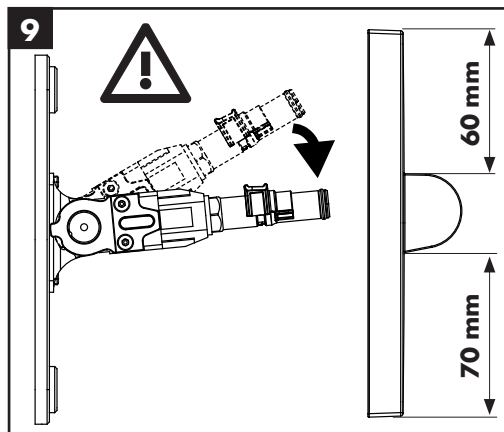
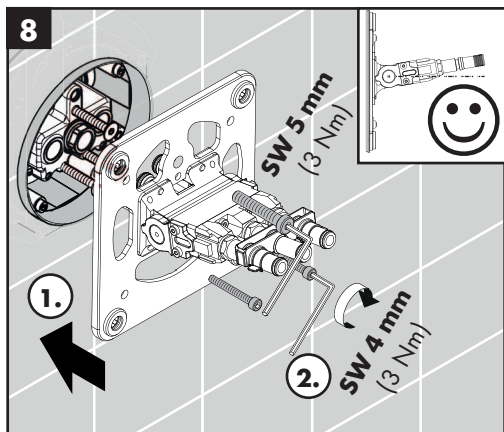
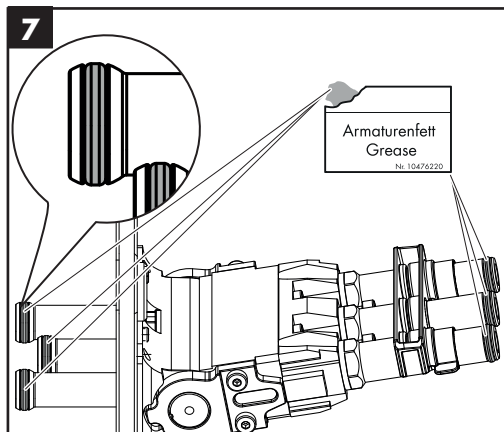
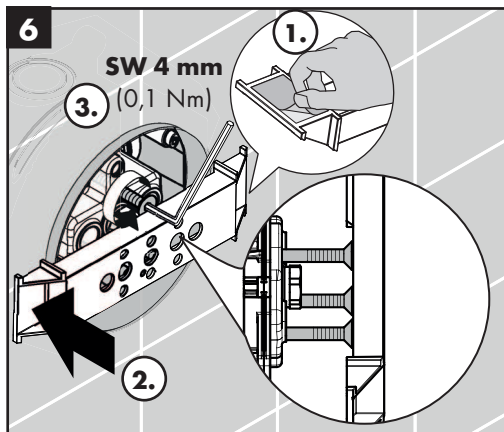

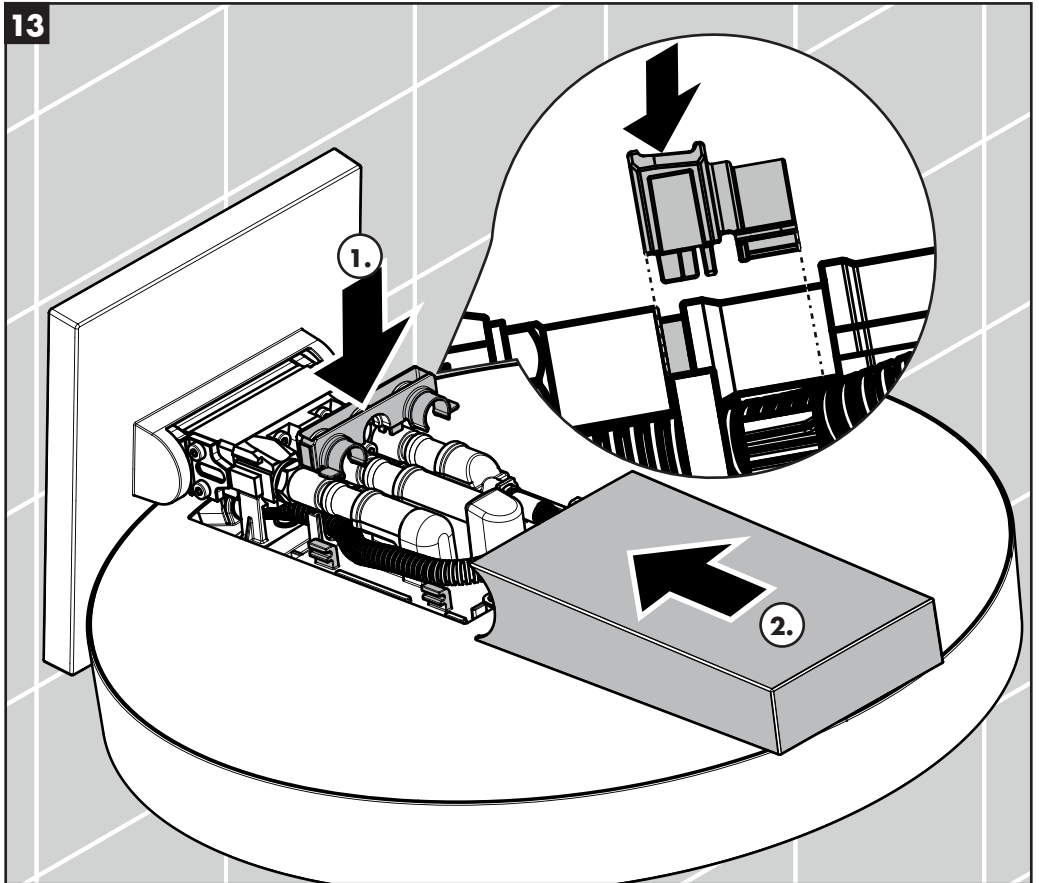
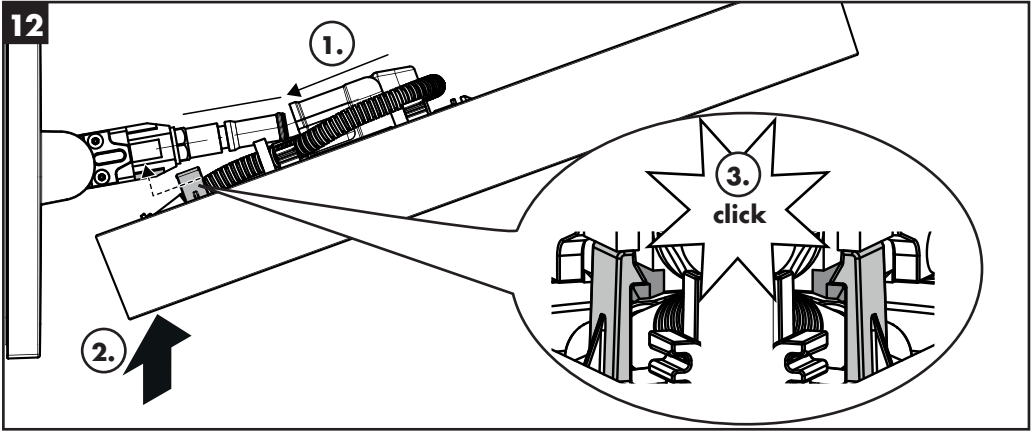



- DE** Reinigungsempfehlung / Garantie / Kontakt
- FR** Recommandation pour le nettoyage / Garanties / Contact
- EN** Cleaning recommendation / Warranty / Contact
- IT** Raccomandazione di pulizia / Garanzia / Contatto
- ES** Recomendaciones para la limpieza / Garantía / Contacto
- NL** Aanbevelingen inzake reiniging / Garantie / Contact
- DK** Rensning, anbefaling / Garanti / Kontakt
- PT** Recomendações de limpeza / Garantia / Contacto
- PL** Zalecenie dotyczące pielęgnacji / Gwarancja / Kontakt
- CS** Doporučení k čištění / Záruka / Kontakt
- SK** Odporúčania pre čistenie / Záruka / Kontakt
- ZH** 清洁指南 / 担保 / 接触
- RU** Рекомендации по очистке / Гарантия / Контакты
- HU** Tisztítási tanácsok / Garancia / érintkezés
- FI** Puhdistussuositus / Takuu / Kosketus
- SV** Rengöringsrekommendationer / Garanti / Contacto
- LT** Valymo rekomendacijos / Garantija / Kontaktai
- HR** Preporuke za čišćenje / Garancija / Kontakt
- TR** Temizleme önerisi / Garanti / Temas
- RO** Recomandări pentru curățare / Garanție / Contact
- EL** Σύσταση καθαρισμού / Εγγύηση / επαφή
- SL** Priporočilo za čiščenje / Garancija / Kontakt
- ET** Puhastussoovitused / Garantii / Kontakt
- LV** Tīrīšanas ieteikumi / Garantija / Kontakti
- SR** Preporuke za čišćenje / Garancija / Kontakt
- NO** Anbefaling for rengjøring / Garanti / Kontakt
- BG** Препоръка за почистване / Гаранция / Контакт
- SQ** Këshilla rreth pastrimit / Garancia / Kontakt
- KO** 세정시 권장사항 / 품질보증 / 접촉
- AR** توصيات التنظيف / الضمان (الولايات المتحدة الأمريكية) / اتصال



[www.hansgrohe.com/
cleaning-recommendation](http://www.hansgrohe.com/cleaning-recommendation)

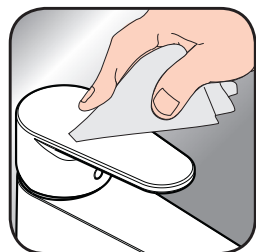

[www.hansgrohe.com/
cleaning-recommendation](http://www.hansgrohe.com/cleaning-recommendation)



[www.hansgrohe.com/
cleaning-recommendation](http://www.hansgrohe.com/cleaning-recommendation)



[www.hansgrohe.com/
cleaning-recommendation](http://www.hansgrohe.com/cleaning-recommendation)



QUICK CLEAN

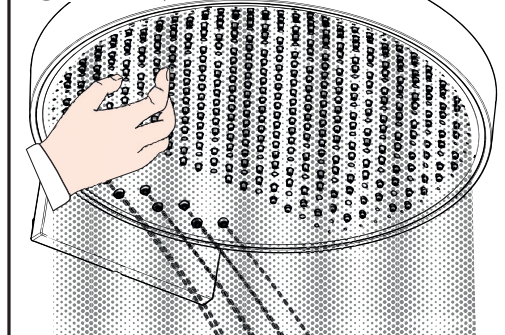

DE Einfach sauber: Kalk lässt sich von den Noppen ganz leicht abrubbeln.

FR La propreté en toute simplicité: les dépôts formés sur les buses élastiques en silicone s'éliminent par un simple passage de la main.

EN Just clean: simply rub over the spray nozzles to remove lime scale.

IT Facile da pulire: Il calcare viene eliminato semplicemente dagli ugelli elastici in silicone.

ES Fácil asear: La cal se puede retirar sencillamente frotando con los dedos de las toberas elásticas de silicona.

NL Eenvoudig schoon: Kalk kan eenvoudig van de noppen worden gewreven.

DK Enkel rengøring: Det er let at fjerne kalkaflejringer fra stråledyserne.

PT Simplesmente limpo: o calcário pode ser simplesmente retirado das saliências através de fricção.

PL Po prostu czysto: Pęczki można całkiem łatwo oczyścić z kamienia.

CS Jednoduše čistě: Vapenné usazeniny můžete z nopků snadno odstranit ořením.

SK Jednoducho čistý: Vodný kameň sa dá zo štetín celkom ľahko odstrániť.

ZH 清洁: 只需要揉搓花洒表面的出水孔即可去除水垢。

RU Простота чистки: известь очень легко стирается с утолщений.

HU Egyszerűen tiszta: a vízkő egészen könnyen ledörzsölhető a csomókról.

FI Yksinkertaisesti puhdas: kalkin voi helposti hieroa irti nypystä.

SV Enkelt att göra rent: det är lätt att ta bort kalk från nopporna.

LT Paprasta švara: kalkės lengvai nugrandomos nuo kilpos.

HR Jednostavno čisto: Kamenac se sasvim lako uklanja s izbočina.

TR Sadece temiz: Kireç, düğümlemlerle kolayca ovalanabilir.

RO Pur și simplu curat: Calcarul se îndepărtează ușor de pe noduri prin frecare.

EL πλά τέλεια καθαριότητα: Τα άλατα μπορούν να αφαιρεθούν με μεγάλη ευκολία από τα στόμια.

SL Preprosto čisto: arnenec se z lahkoto podrgne z vozličkov.

ET Lihtsalt puhas: luoja saab nupudelt lihtsalt maha hõõruda.

LV Vienkārša tīrīšana: kaļķis no izvīrzījumiem ir viegli norubināms.

SR Jednostavno čisto: Kamenac se sasvim lako skida sa izbočina.

NO Simpelt en ren: Ved å gnikke er det lett å fjerne kalk fra nuppene.

BG Просто чисто: Варовикът лесно може да се изтръси от удебеленията.

SQ Thjesht dhe pastër. Mbetjet gëlqerore mund të hiqen me fërkim të lehtë.

AR إنه سهل التنظيف، حيث يسقط الجير بسهولة شديدة من الأجزاء الناتئة.

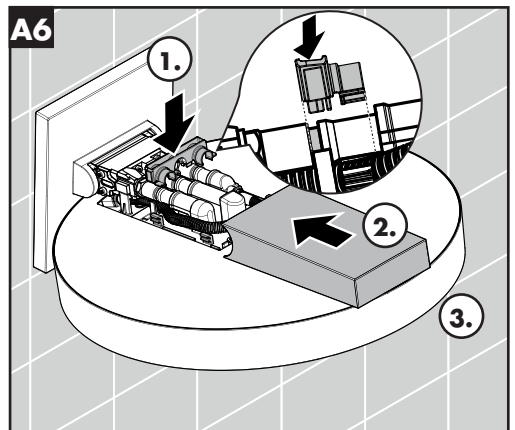
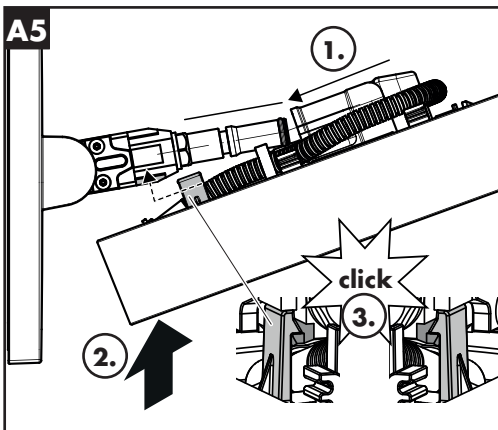
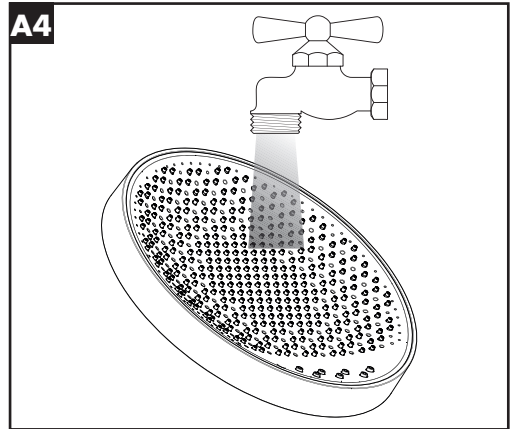
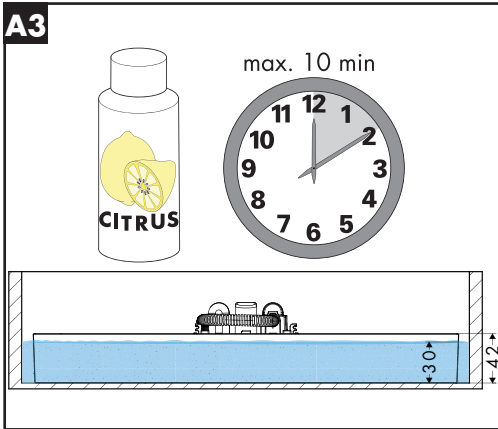
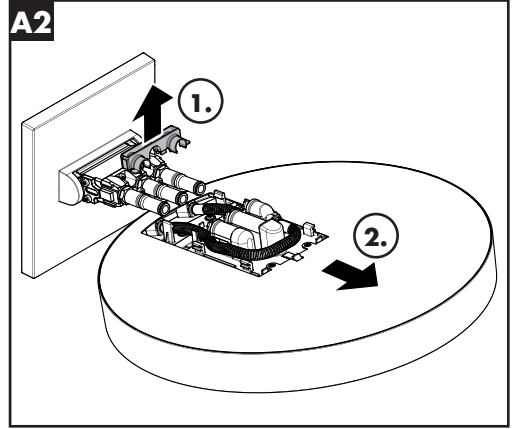
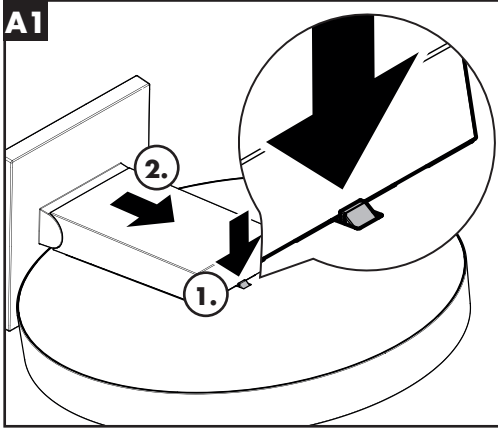

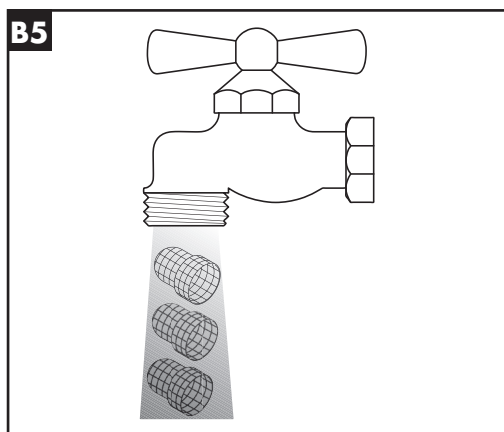
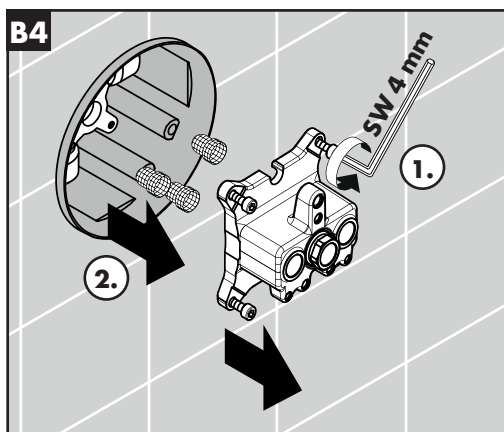
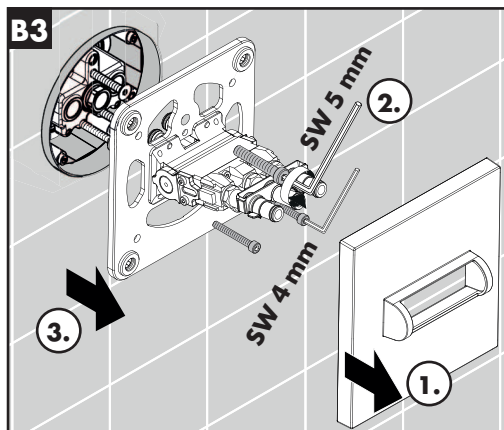
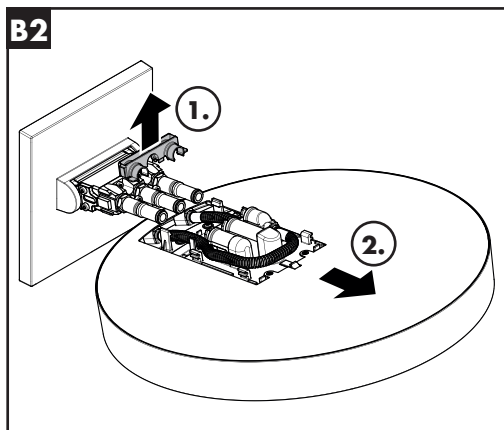
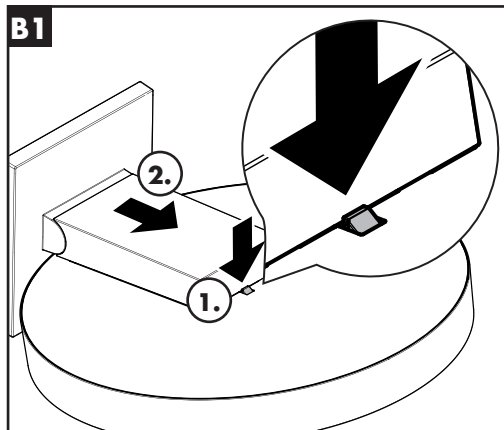
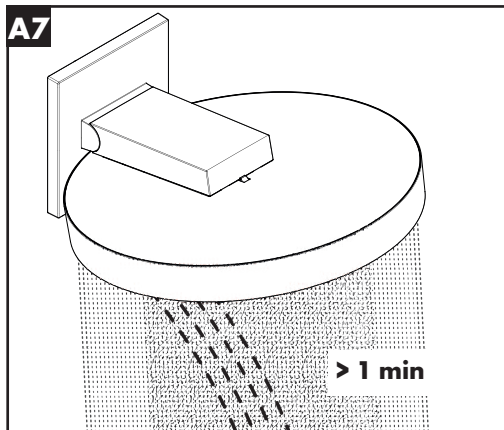

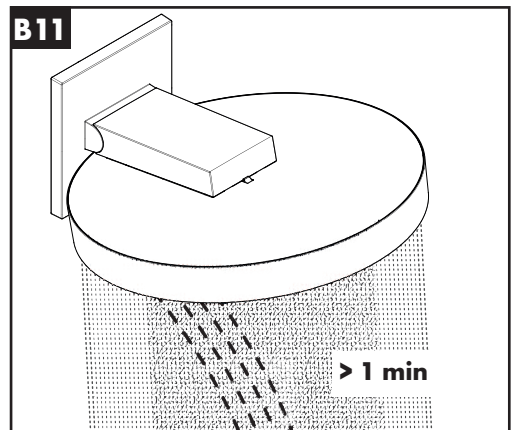
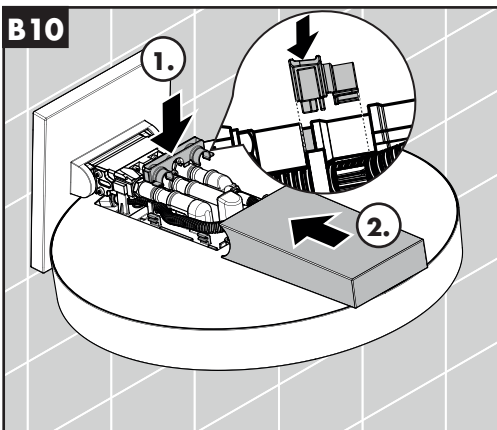
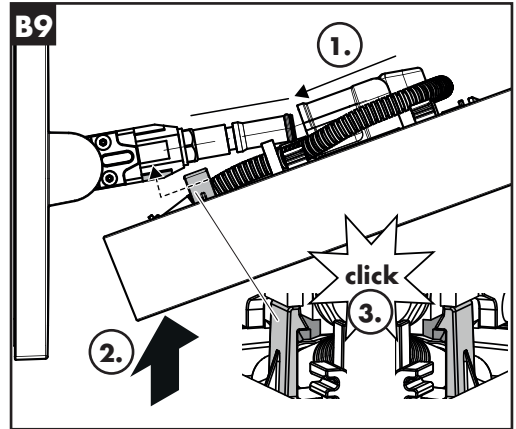
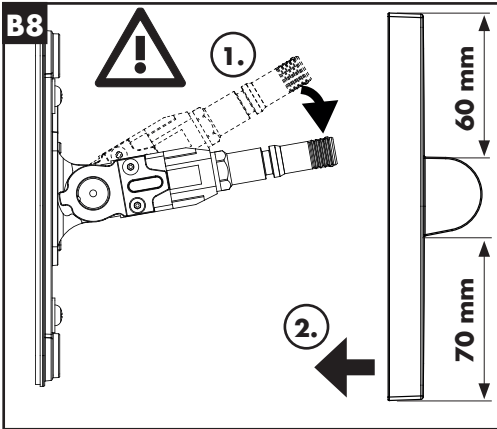
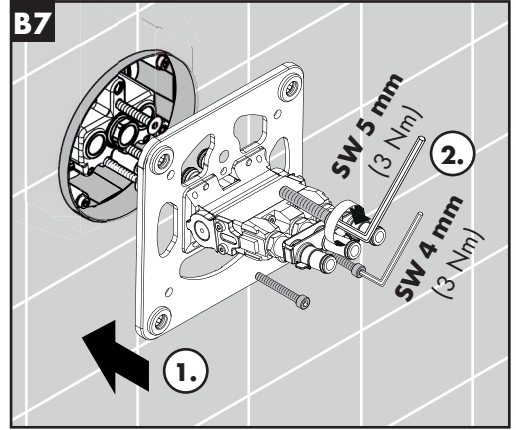
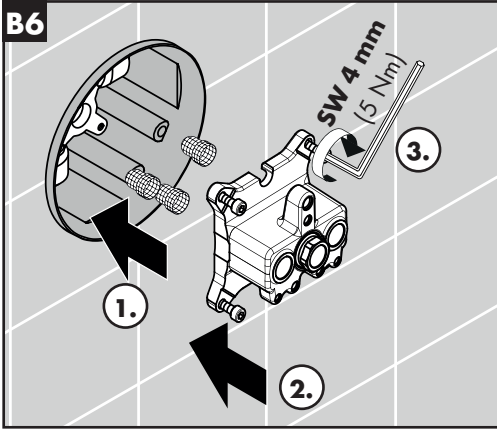



Rainfinity 360 3jet

26234XXX

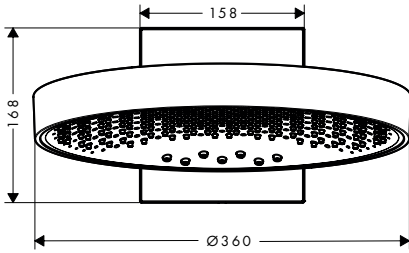
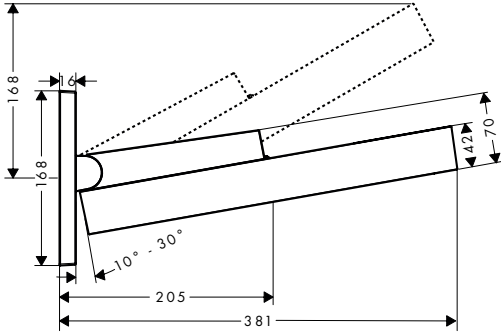

Rainfinity 250 3jet

26232XXX

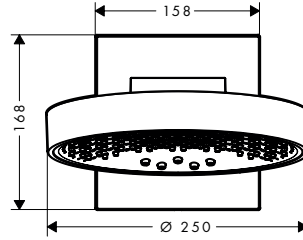
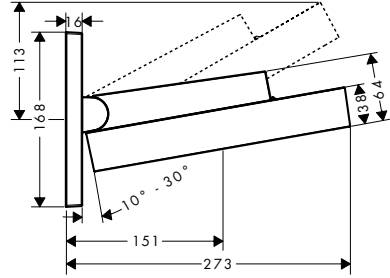

Rainfinity 360 3jet

26234XXX

Rainfinity 250 3jet

26232XXX

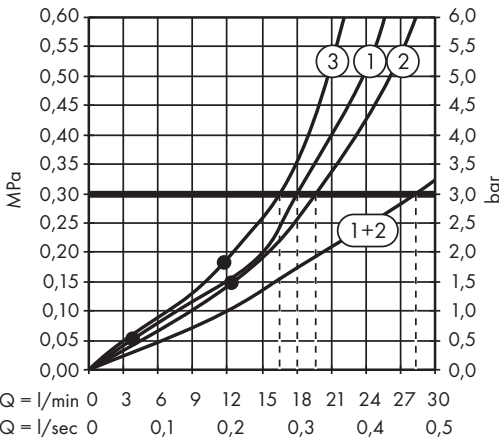

- ① Intense PowderRain
- ② PowderRain
- ③ RainStream





Rainfinity 360 3jet

26234XXX

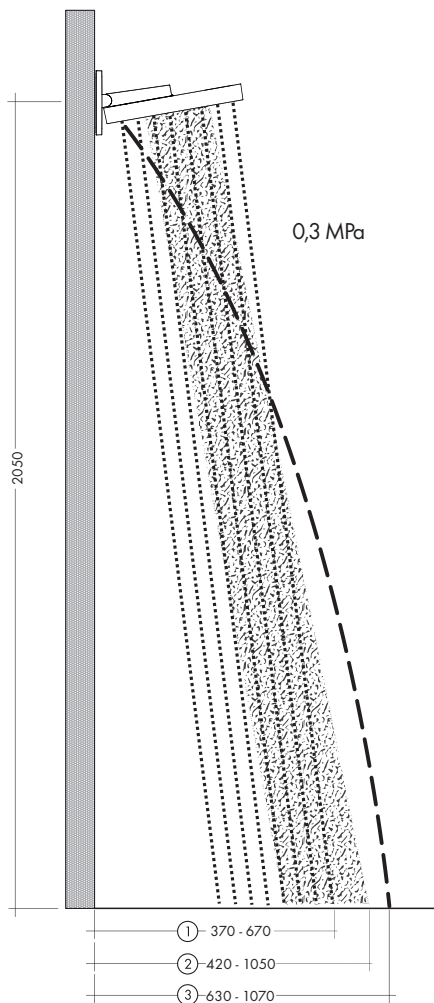

Rainfinity 250 3jet

26232XXX

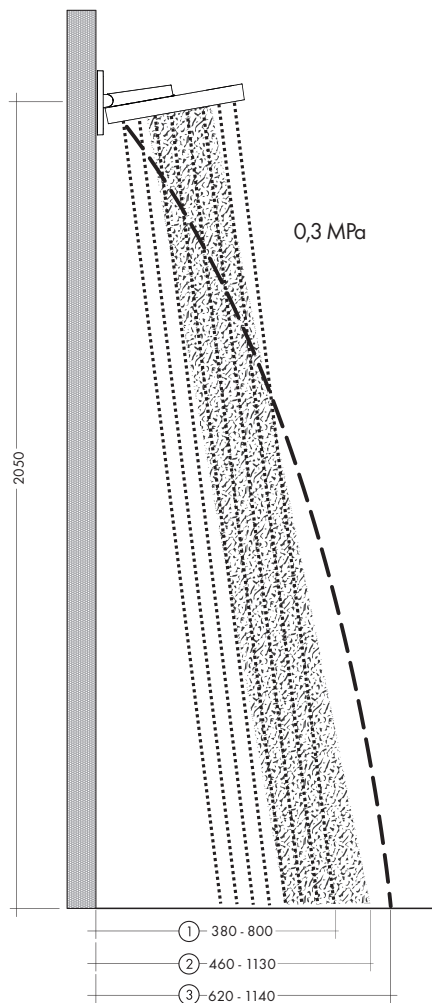

① PowderRain

② Intense PowderRain

③ RainStream



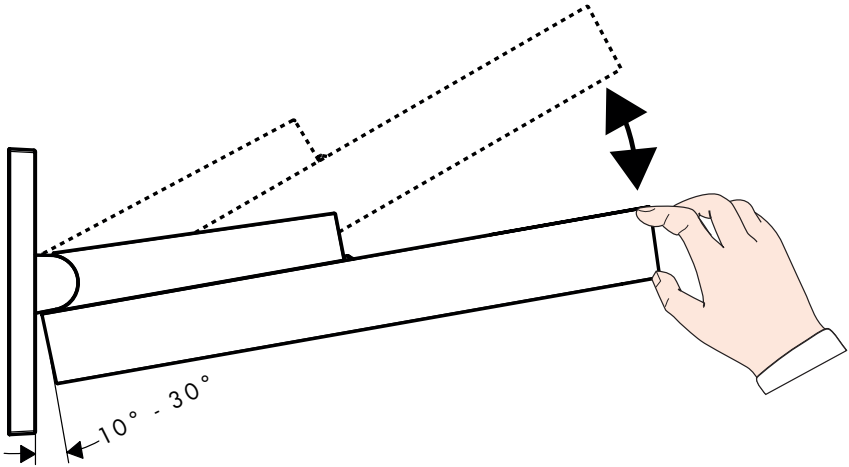

leichter
plus facile
easier
più facile
más ligero
lichter
lettere
più allentato
stabilej
snazší

l'ahšie
更加简单
Легче
helpommin
lättere
lengviau
lakše
daha hafif
mai uşor
ευκολότερα

lažje
kegem
vieglāks
lakši
lettere
lēk
mē i lehtë
أسهل
kōnyebb

schwerer
mais difícil
harder
più difficile
más pesado
zwaardder
tyngre
più serrat
mocniej
obtížnějši

f'azšie
更坚固
Стабильнее
vaikėampī
tyngre
Sunkiau
Teže
ağır
mai greu
βαρύτερα

težje
raskem
smagāks
teže
tyngre
по-трудно
mē e rēndē
أصلب
nehezebb

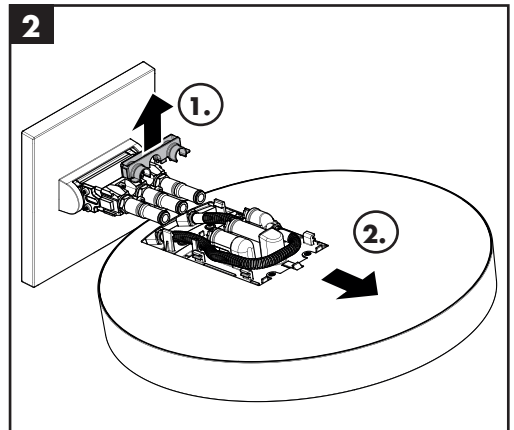
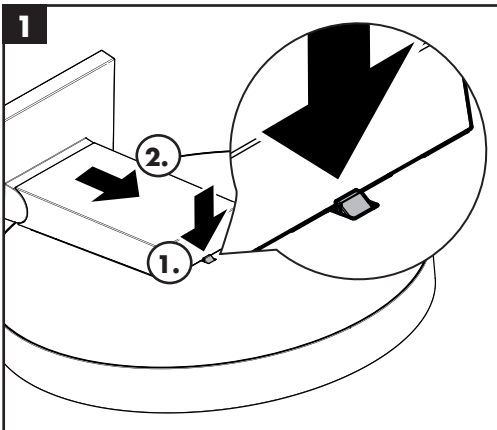



3

SW 3 mm

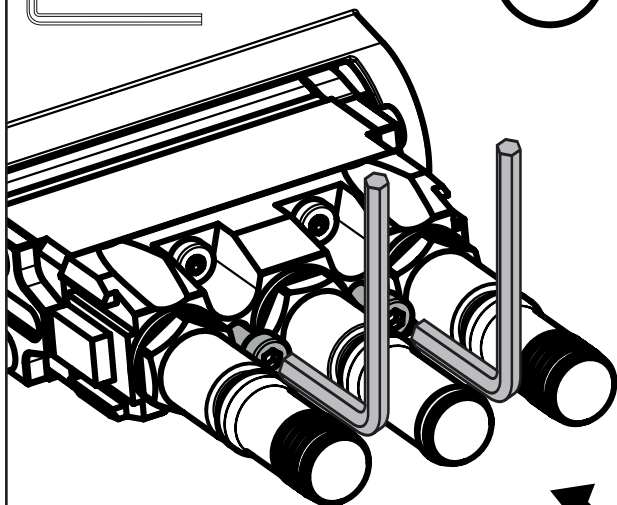

schwerer	t'ažšie	težje
mais difícil	更坚固	raskem
harder	Стабильнее	smagāks
più difficile	vaikeampi	teže
más pesado	tyngre	tyngre
zwaarder	sunkiau	по-трудно
tyngre	Teže	më e rëndë
più serrat	ağır	أصعب
mocniej	mai greu	nehezebb
obtěžnějši	βαρύτερα	

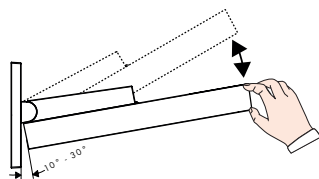

leichter	l'ahšie	lažje
plus facile	更加简单	kergem
easier	Легче	vieglāks
più facile	helpommin	lakši
más ligero	lāttare	lettere
lichter	lengviau	лек
lettere	lakše	më i lehtë
più allentato	daha hafif	أسهل
stąbiej	mai ușor	könnyebb
snazši	ευκολότερα	

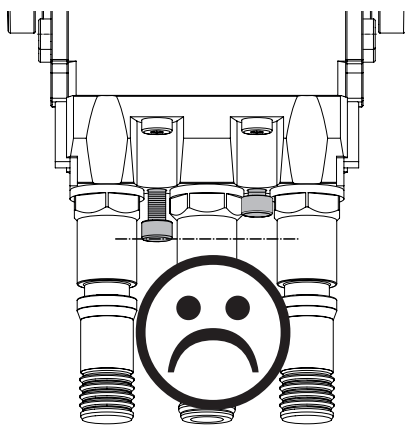
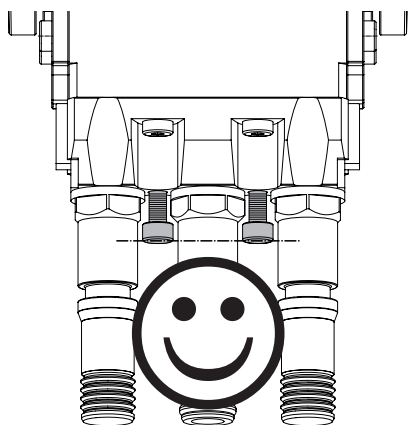

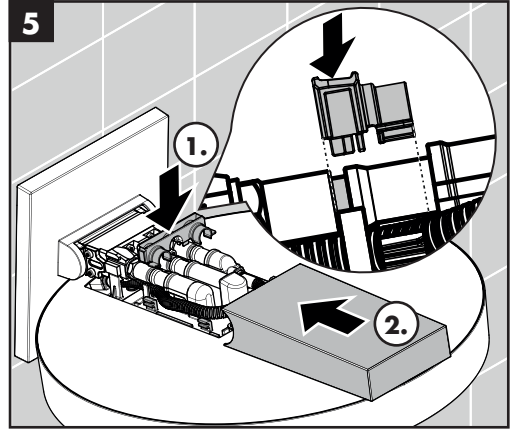
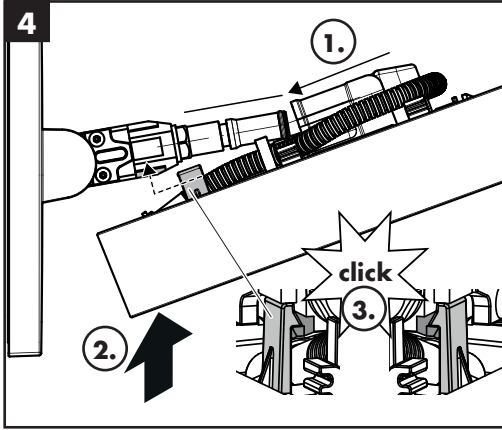

hansgrohe

ОФИЦИАЛЬНЫЙ ДИЛЕР В УКРАИНЕ:

storgom.ua

ГРАФИК РАБОТЫ:

Пн. – Пт.: с 8:30 по 18:30

Сб.: с 09:00 по 16:00

Вс.: с 10:00 по 16:00

КОНТАКТЫ:

+38 (044) 360-46-77

+38 (066) 77-395-77

+38 (097) 77-236-77

+38 (093) 360-46-77

Детальное описание товара:

<https://storgom.ua/product/hansgrohe-194404.html>

Другие товары: <https://storgom.ua/lejki-dla-dusa.html>