



DOMEK NARZĘDZIOWY MANOR 6x8DD

INSTRUKCJA MONTAŻU I UŻYTKOWANIA



PRZYGOTOWANIE MIEJSCA DO MONTAŻU

Wyrównać grunt

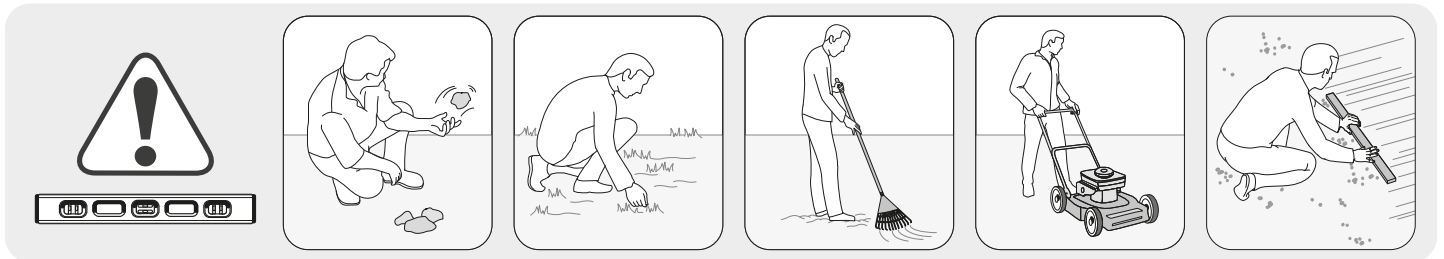

Zaleca się przygotowanie drewnianej lub betonowej podstawy jako fundamentu.

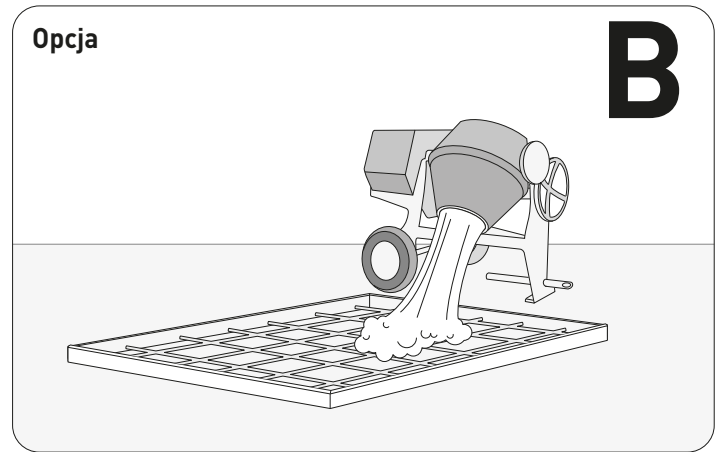
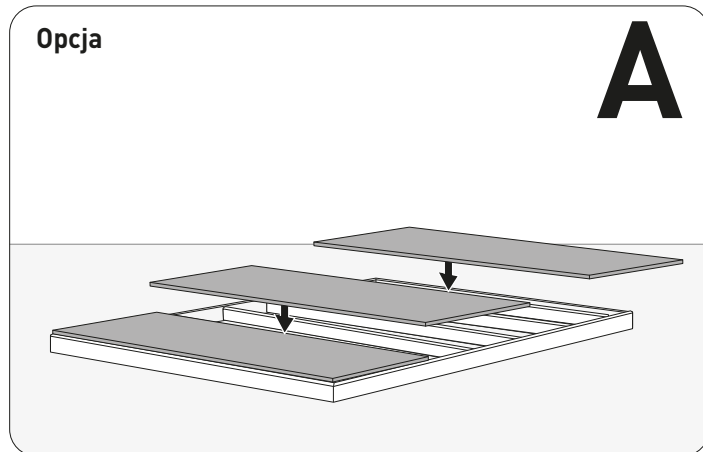

Do właściwego montażu należy zachować odpowiednią ilość wolnego miejsca wokół domku narzędziowego.

Wymiary zewnętrzne podłogi:

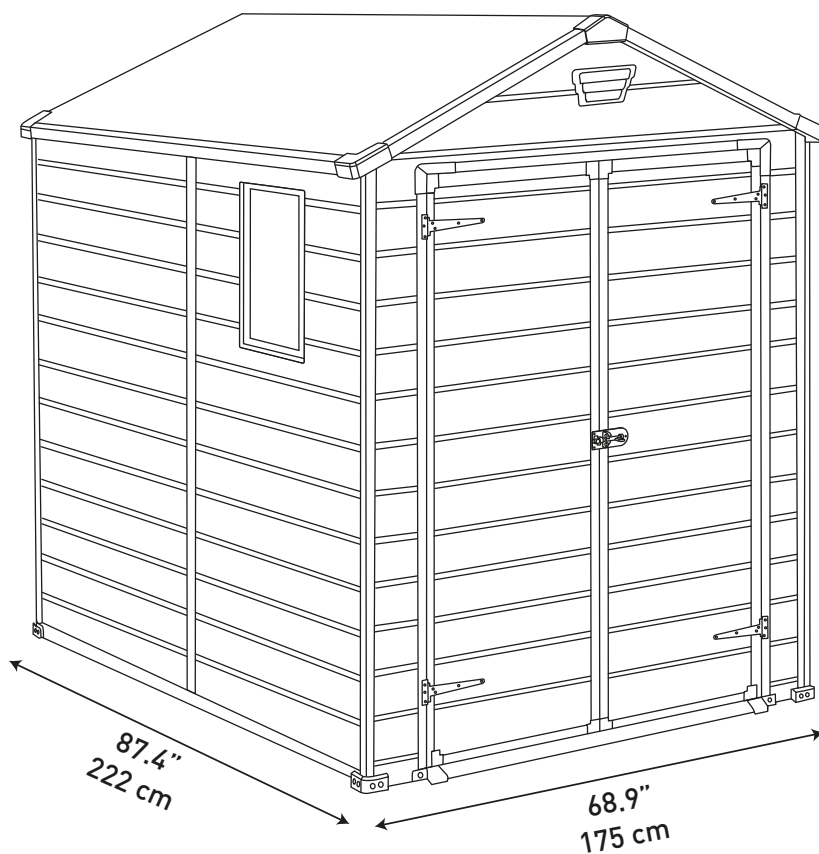

PRZED ROZPOCZĘCIEM MONTAŻU

Należy zapoznać się z zaleceniami w zakresie bezpieczeństwa umieszczonymi na końcu tej instrukcji | Przed przystąpieniem do montażu należy zapoznać się z instrukcją | Montaż wszystkich elementów powinien być wykonany zgodnie z instrukcją | Nie należy pomijać żadnego z etapów.

WYMAGANE NARZĘDZIA

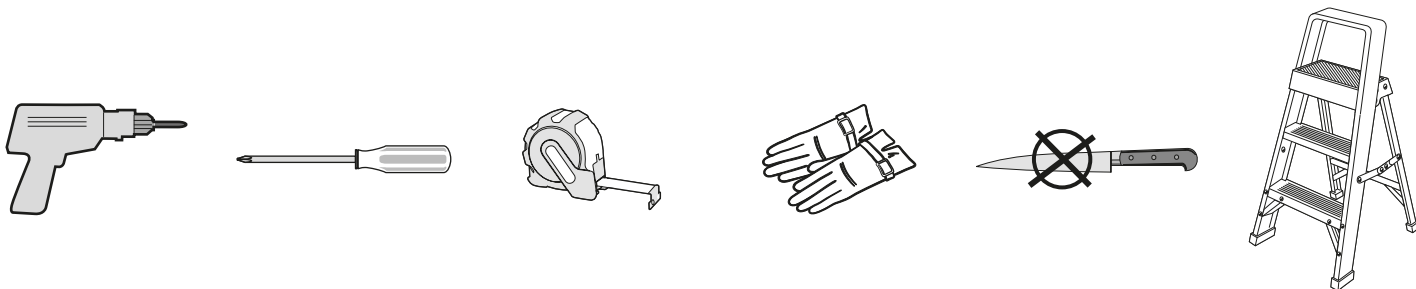

SZPATUŁKA

Stosować szpatułkę (część „SPA”) do łatwiejszego wkładania płyt w profile.

spa x1

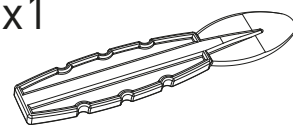

DO MONTAŻU POTRZEBNE SĄ DWIE OSOBY.

CZĘŚCI DOMKU NARZĘDZIOWEGO

Wszystkie elementy należy wyciągnąć z opakowania (-ań) i rozłożyć na uprzednio przygotowanej do pracy powierzchni. Dla łatwiejszej identyfikacji części oznaczone są literami.

ŚRUBY

s13b (x39) 0.47"/12 mm

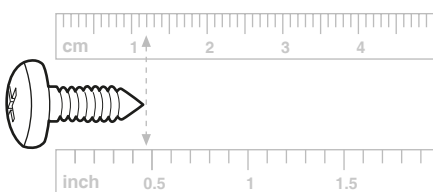

s26b (x144) 1"/26 mm

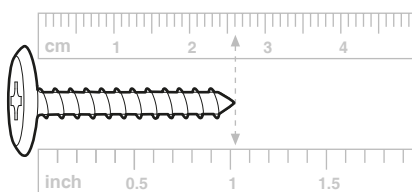

sc15 (x17) 0.63"/16 mm

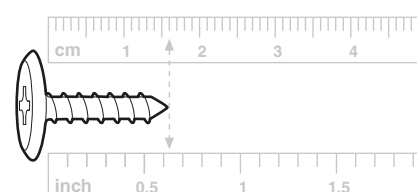

WKRETY

s50b(x2) 1.97"/50 mm

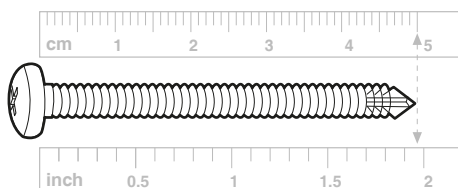

ds2b(x18) 0.39"/10 mm

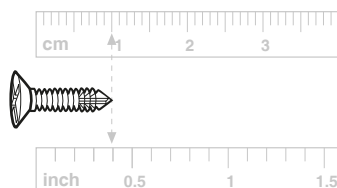

s10b(x28) 0.47"/12 mm

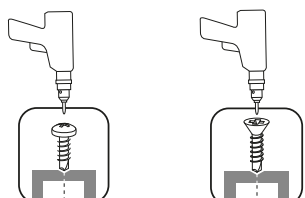
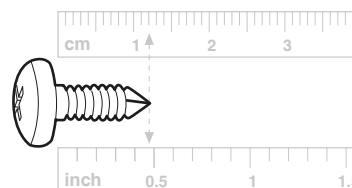



Należy użyć mocnej wkrętarki elektrycznej. Śruby powinny zostać wkręcone do metalowego profilu.

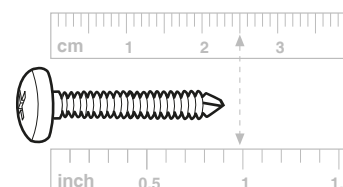

s23b(x4) 0.98"/25 mm

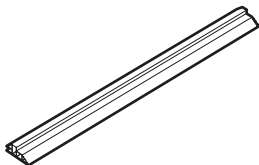
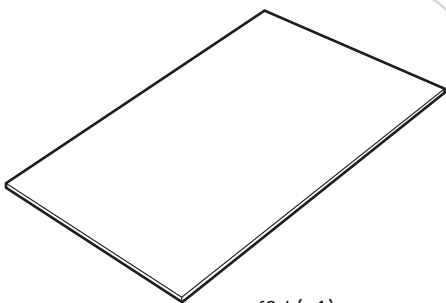

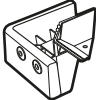
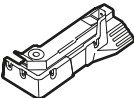
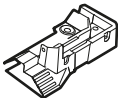

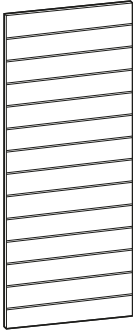
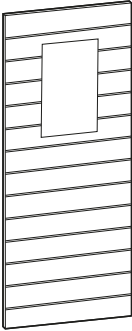
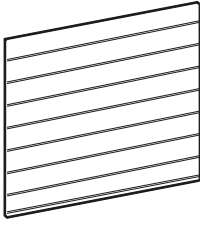
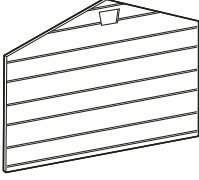
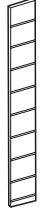
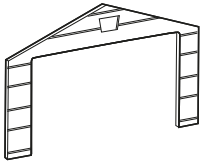
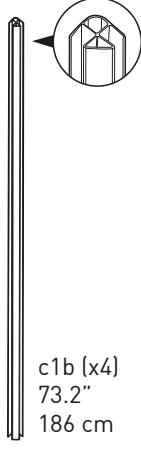
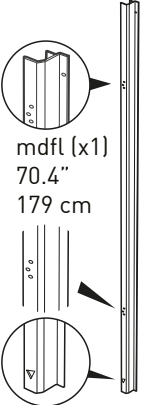
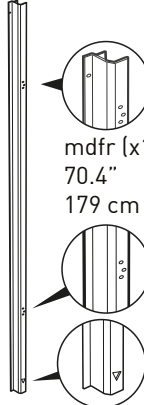
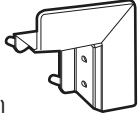

CZĘŚCI PODŁOGI

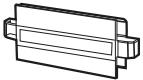
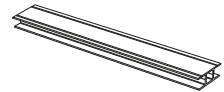
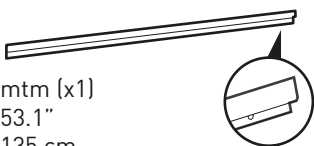
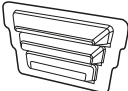
<p>c1g (x2) 85.4" 217 cm</p> 	<p>d1b (x1) 52.4" 133 cm</p> 			
<p>c1a (x1) 64.5" 164 cm</p> 	<p>t (x2)</p> 	<p>msl (x1)</p> 	<p>msr (x1)</p> 	<p>f2d (x1) 66.5" x 86.6" 169 x 220 cm</p>

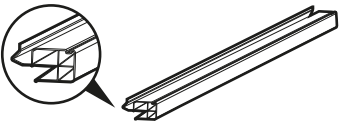

CZĘŚCI ŚCIAN

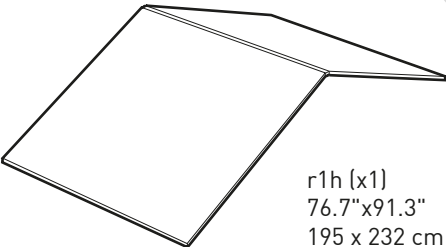
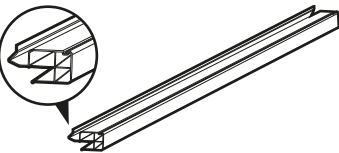
					
<p>w1c (x3) 39.8" x 73.6" 101 x 187 cm</p>	<p>s1c (x1) 39.8" x 73.6" 101 x 187 cm</p>	<p>bd1a (x1) 66.5" x 42.9" 169 x 109 cm</p>	<p>bu1a (x1)</p>	<p>fd2b (x2) 6.7" x 51.5" 17 x 131 cm</p>	<p>fu2a (x1)</p>
			<p>mdt (x2)</p> 	<p>h1a (x2) 72.4" 184 cm</p> 	
<p>c1b (x4) 73.2" 186 cm</p>	<p>mdfl (x1) 70.4" 179 cm</p>	<p>mdfr (x1) 70.4" 179 cm</p>	<p>lm (x1)</p> 	<p>h1b (x1) 65" 165 cm</p> 	
			<p>mtm (x1) 53.1" 135 cm</p> 	<p>v (x2)</p> 	

CZĘŚCI SUFITU

<p>e1g (x4) 33" 84 cm</p> 	<p>b1a (x1) 90.5" 230 cm</p> 		
<p>e1e (x2) 85" 216 cm</p> 	<p>kc (x2)</p> 	<p>rc (x4)</p> 	<p>r1h (x1) 76.7" x 91.3" 195 x 232 cm</p>

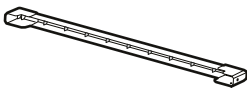
CZĘŚCI DRZWI

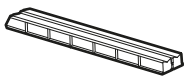
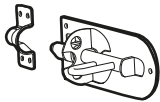
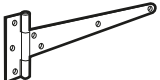
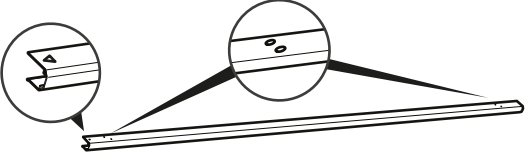
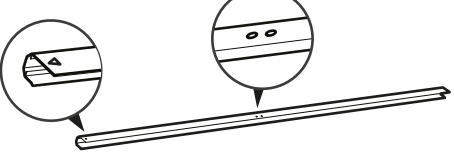
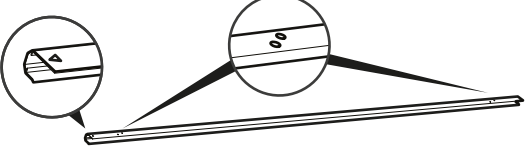
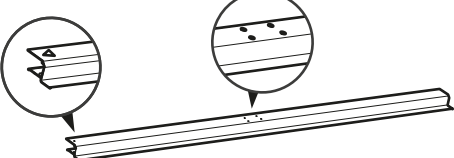
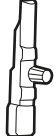
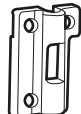
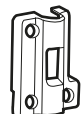
 <p>mdd (x2) 70.1" x 25.6" 178 x 65 cm</p>	 <p>rdd (x2)</p>	 <p>ldd (x2)</p>	 <p>dc (x5)</p>
 <p>db1 (x1)</p>		 <p>dh (x4)</p>	
 <p>mfr 70.4" 179 cm</p>	 <p>mdr 70.4" 179 cm</p>		
 <p>mfl 70.4" 179 cm</p>	 <p>mdl 70.4" 179 cm</p>		
 <p>mpn (x2)</p>	 <p>mtl (x1)</p>	 <p>mbl (x1)</p>	

CZĘŚCI OKIEN

 <p>f-in (x1)</p>	 <p>f-out (x1)</p>	 <p>acw (x1)</p>	 <p>pls (x1)</p>
--	---	--	---

CZĘŚCI KONSTRUKCJI

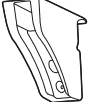
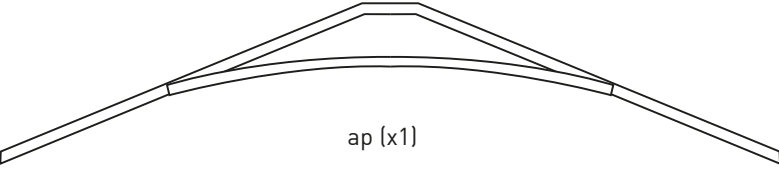
 <p>sh (x1)</p>	 <p>ac (x2) 1" 26 mm</p>	 <p>ap (x1)</p>
--	---	---

Opakowanie może zawierać również dodatkowe małe części, które mogą być wykorzystane jako części zamienne.

UWAGA: Ze względu na uwarunkowania wynikające z procesu produkcji, po złożeniu domku jego rzeczywisty rozmiar może nieznacznie różnić się od wymiarów podanych w specyfikacji.

MONTAŻ PODŁOGI

1

f2d (x1)
66.5" x 86.6"
169 x 220 cm

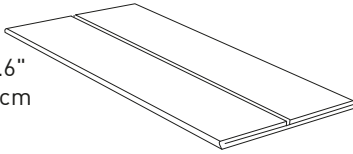

Czarny składany panel

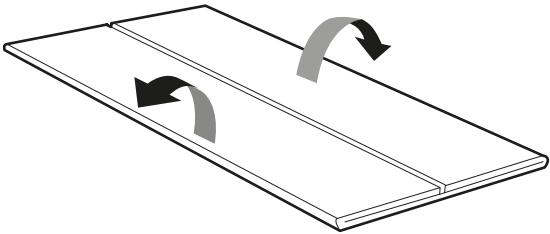

Uwaga: Linia cięcia podłogi powinna być skierowana do dołu.

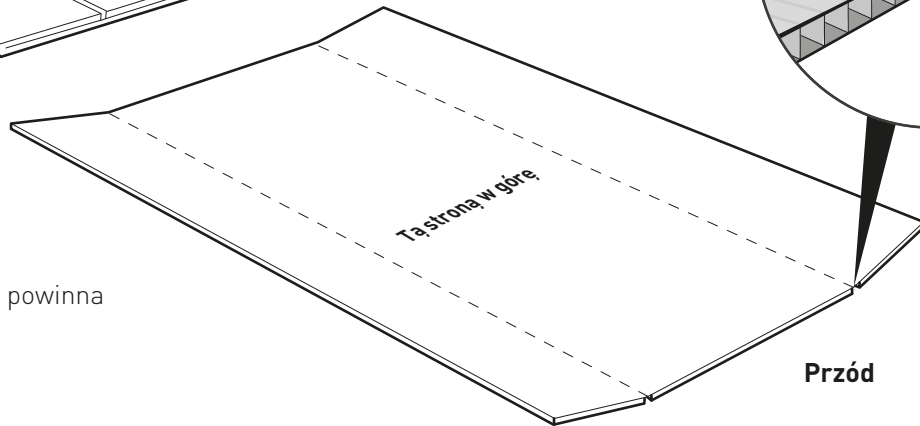

2

c1a (x1)
64.5"
164 cm

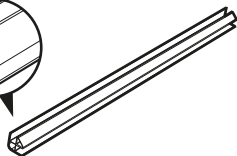

c1g (x2)
85.4"
217 cm

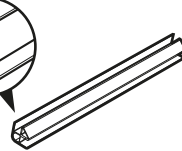

t (x2)

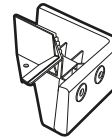

sc15 (x2)
0.63"
16 mm

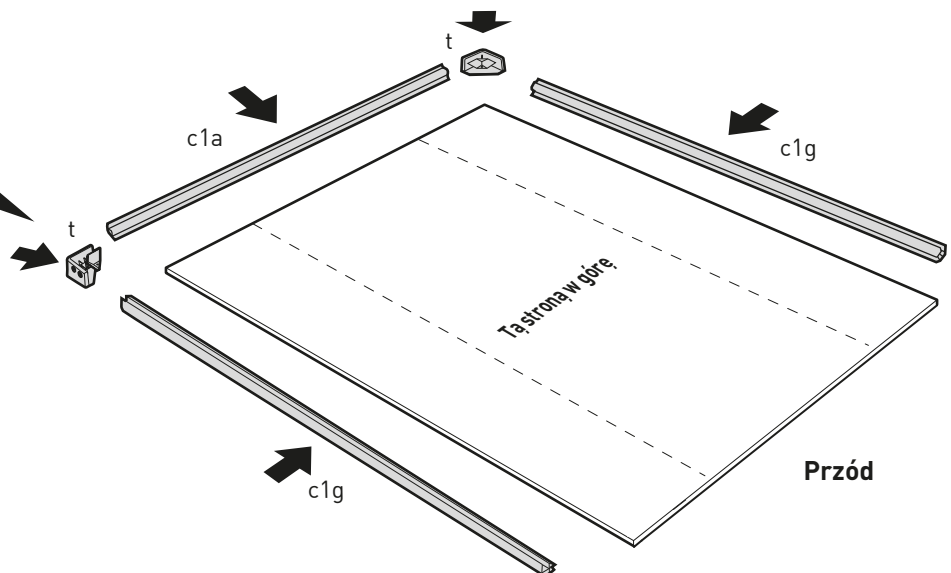
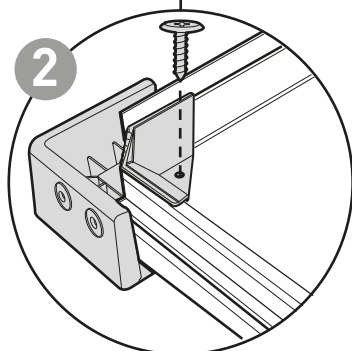
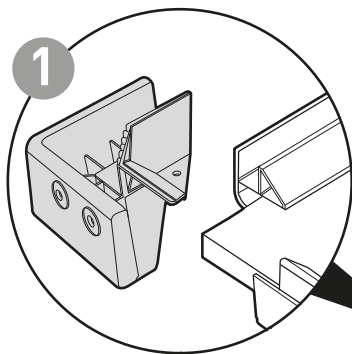
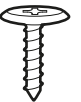

3

d1b (x1)

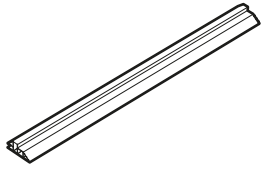

msl (x1)

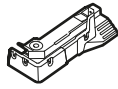

msr (x1)

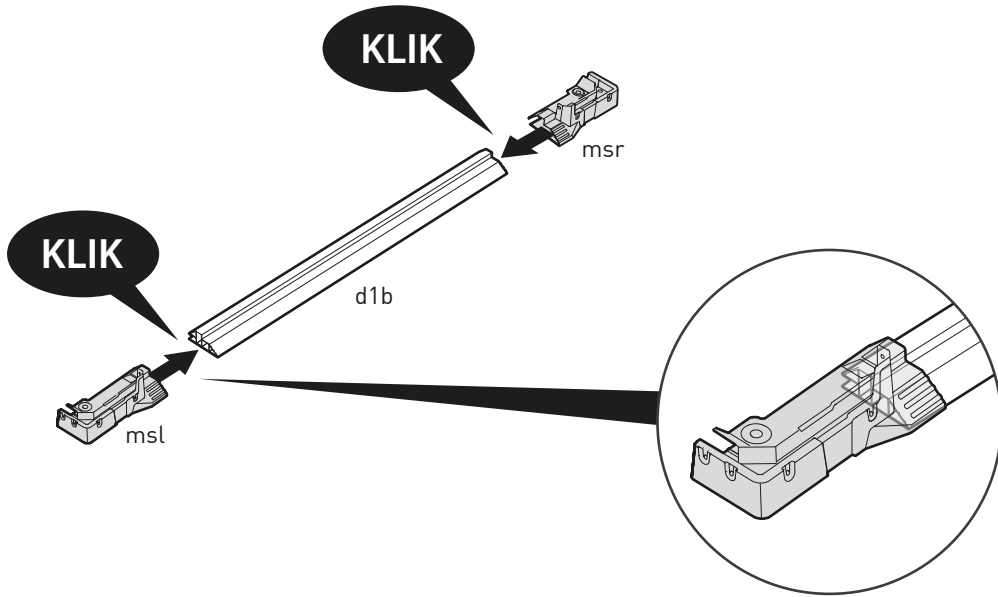
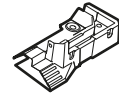

4

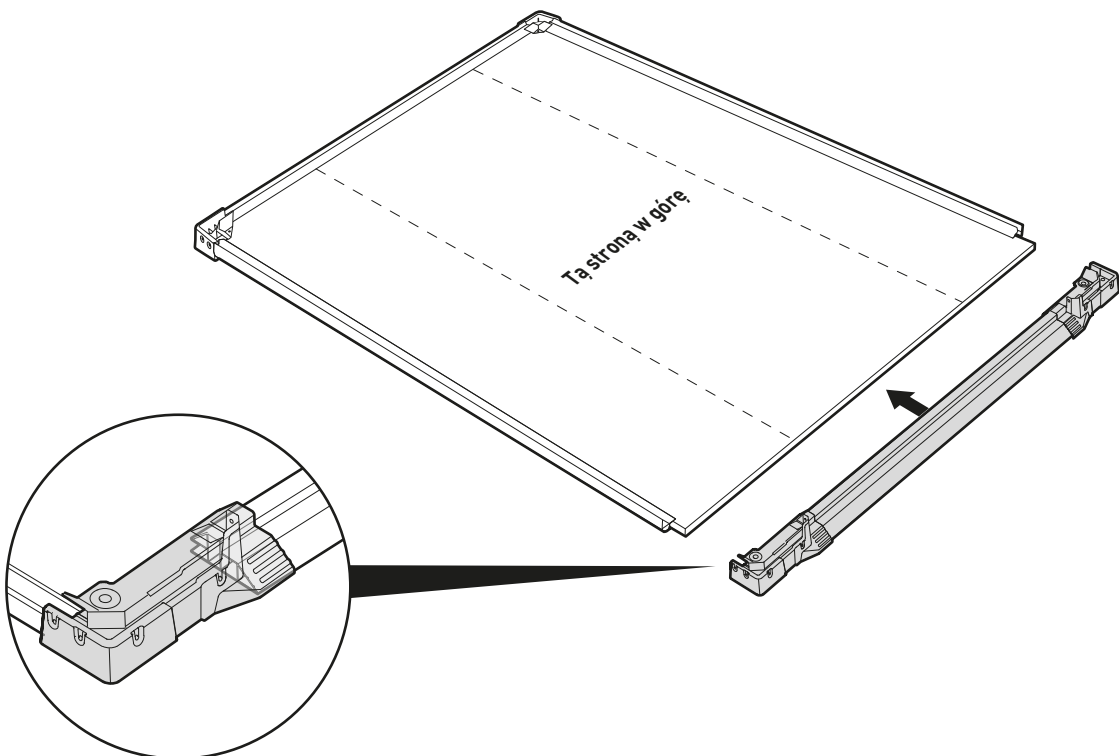
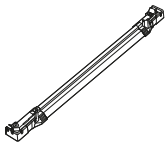

5

A

Obrócić panel podłogowy.

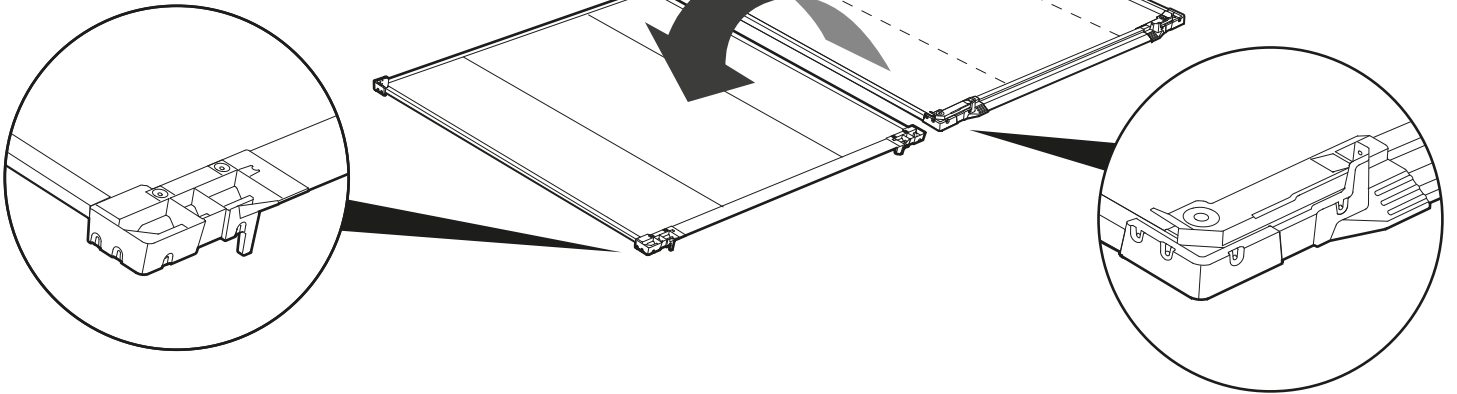

B

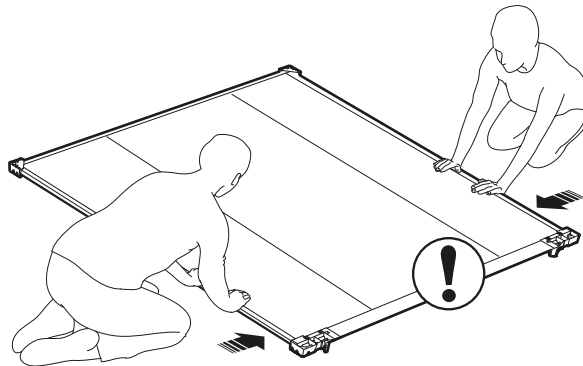

6

sc15 (x8)
0.63"
16 mm

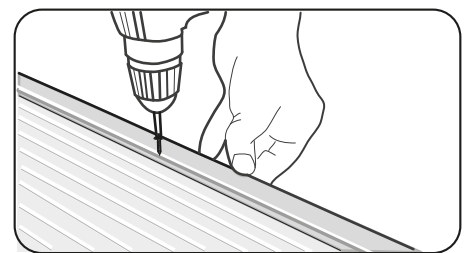
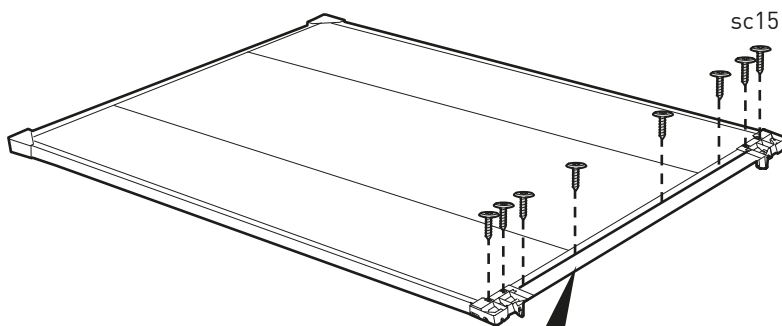
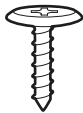

Wsunąć do końca panel w profile i przykręcić śrubami wzdłuż zaznaczonej linii.

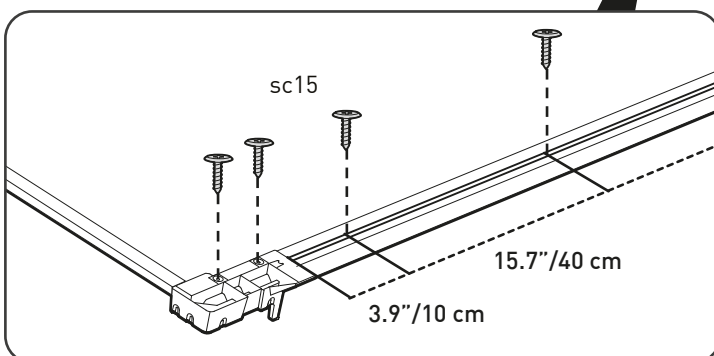

7

s26b (x16)
1"
26 mm

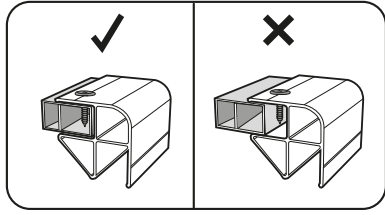
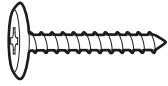

Wsunąć do końca panel w profile.

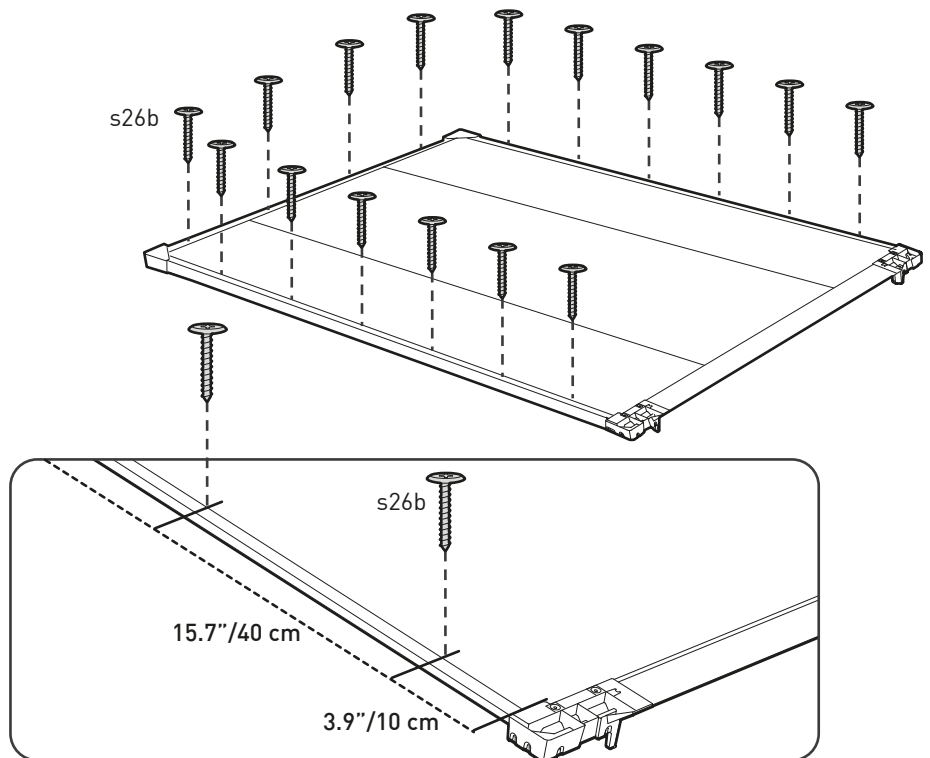

8

Obrócić panel podłogowy.

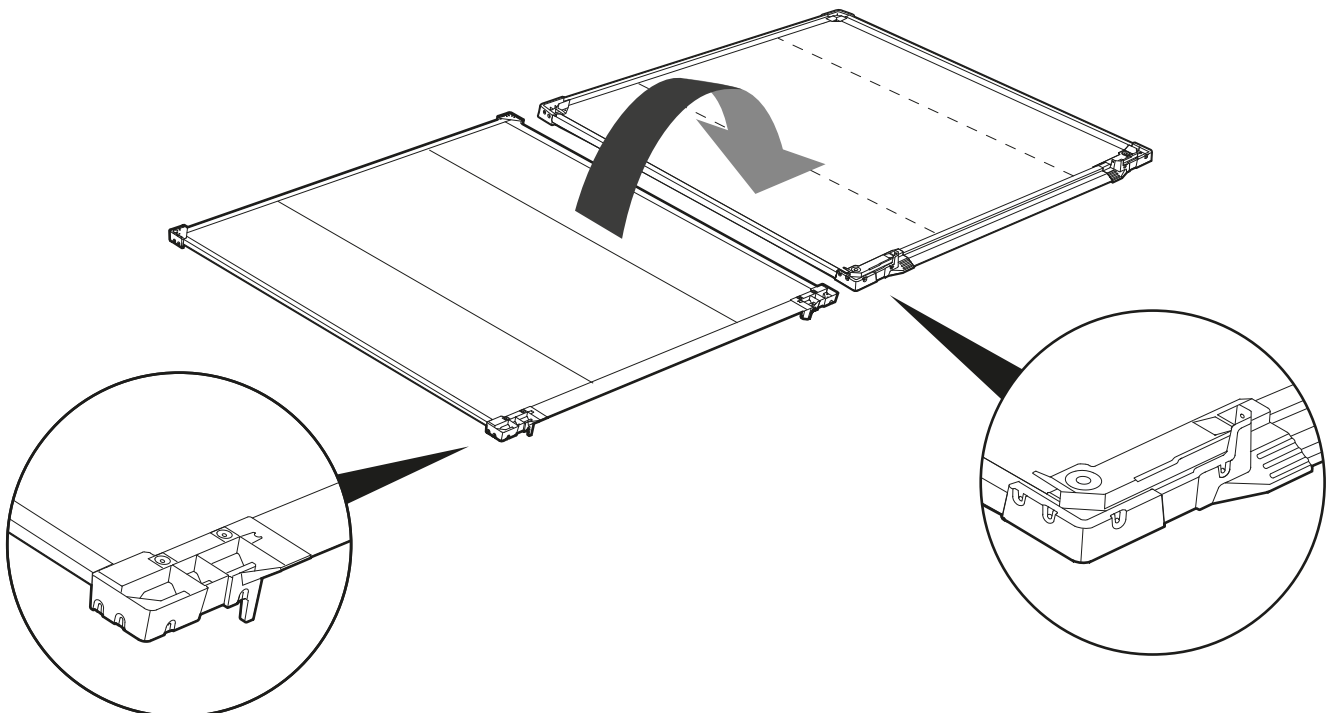

MONTAŻ ŚCIAN

Wybierz, w którym miejscu chcesz umieścić okno.

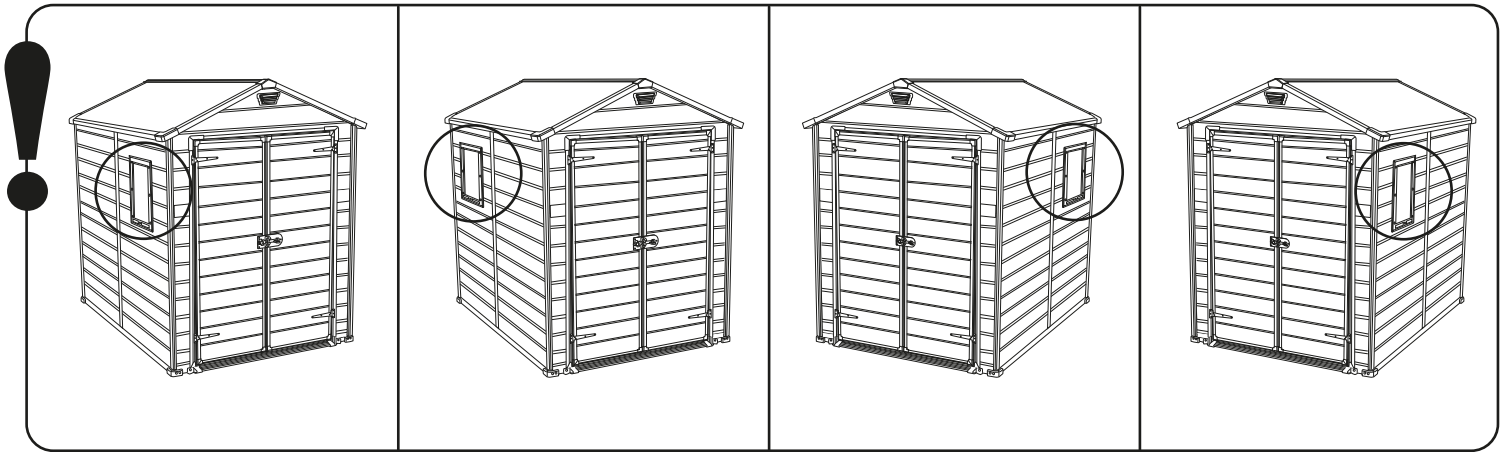
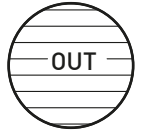
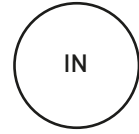

9

c1b (x1)
73.2"
186 cm



bd1a (x1)
42.9" x 66.5"
109 x 169 cm

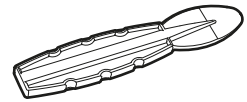
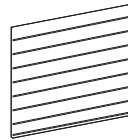

Stosować szpatułkę (część „SPA”) do łatwiejszego wkładania płyt w profile.

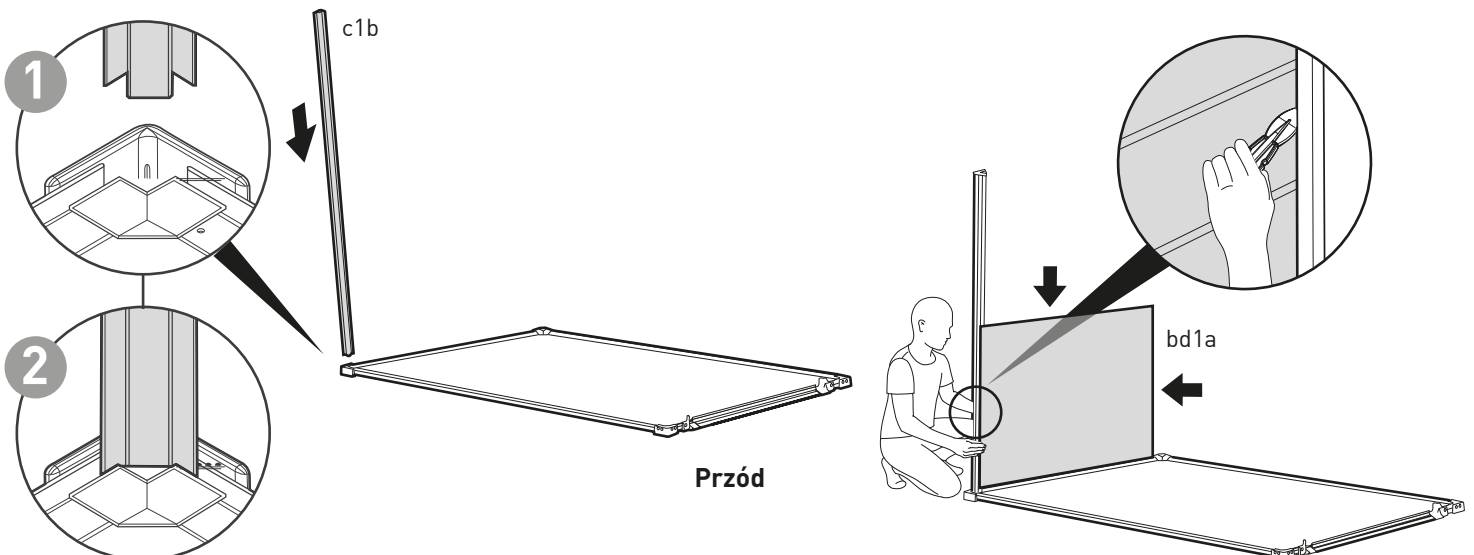

10

w1c (x1)
39.8" x 73.6"
101 x 187 cm

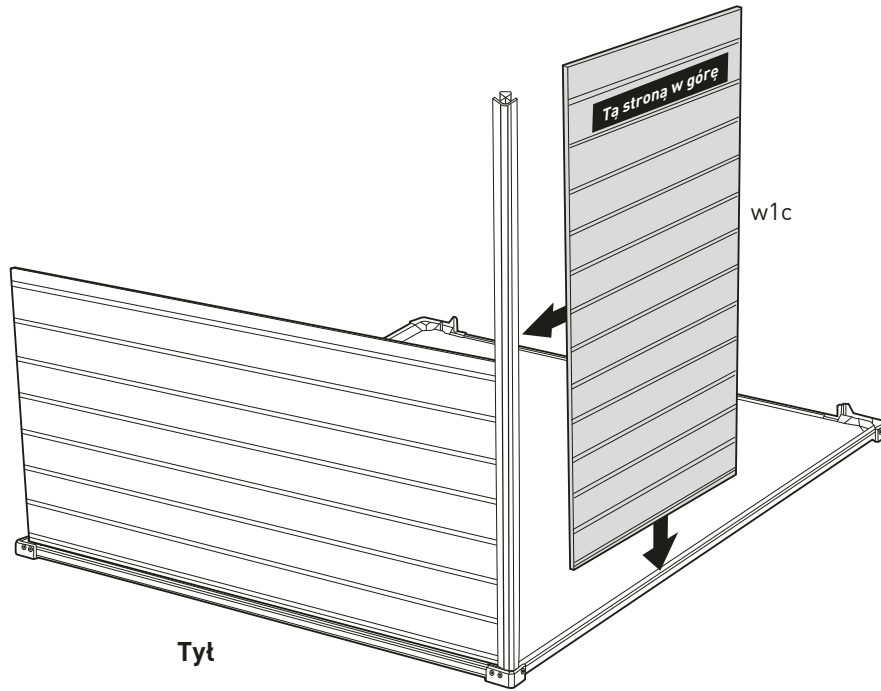
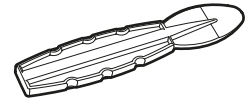

11

s26b (x8)
1"
26 mm

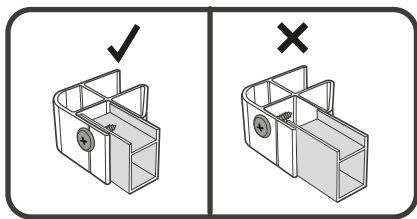
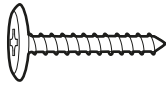

Wsunąć do końca panel w profile.

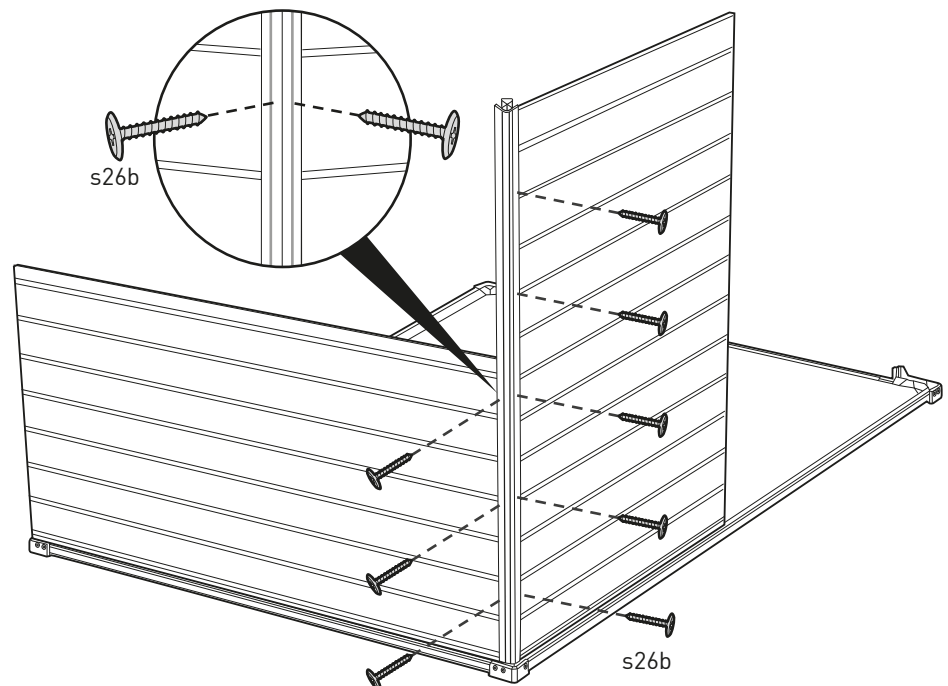

12

h1b (x1)
65"
165 cm

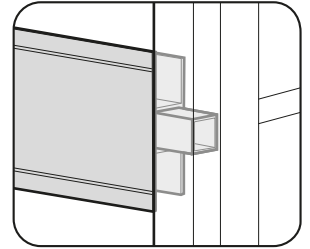
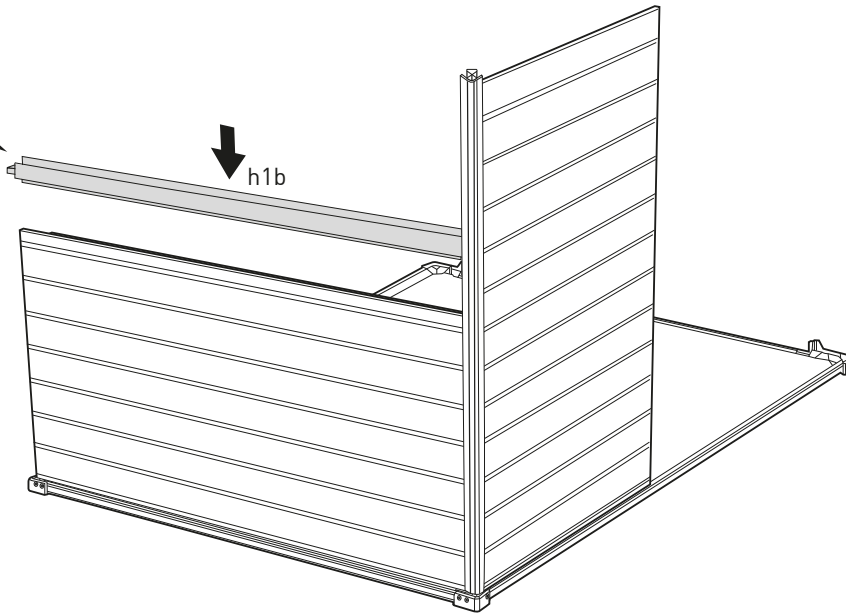
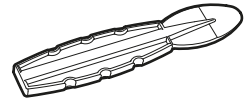
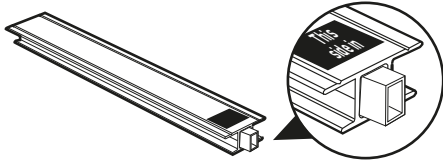

Te części się stykają.

13

c1b (x1)
73.2"
186 cm



bu1a (x1)

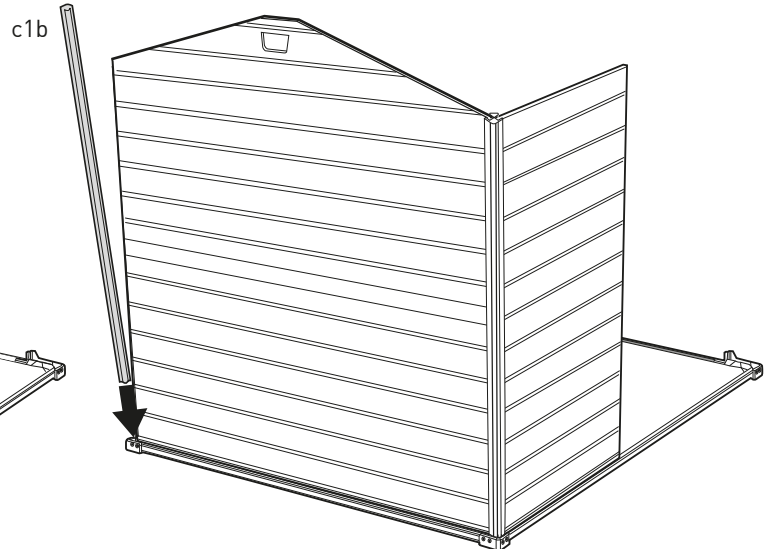
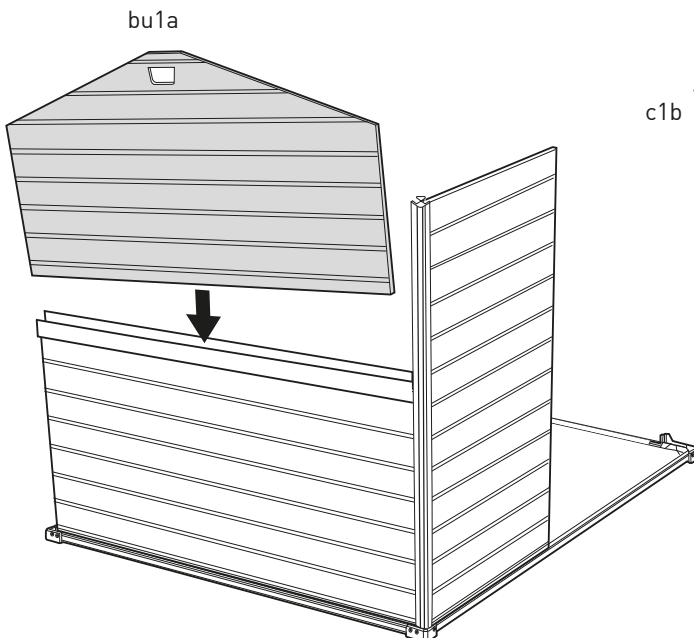
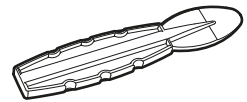
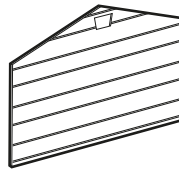

14

s26b (x7)
1"
26 mm

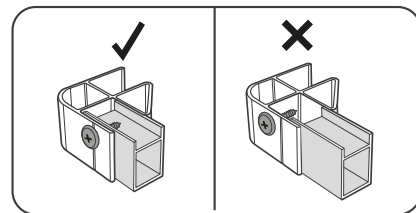
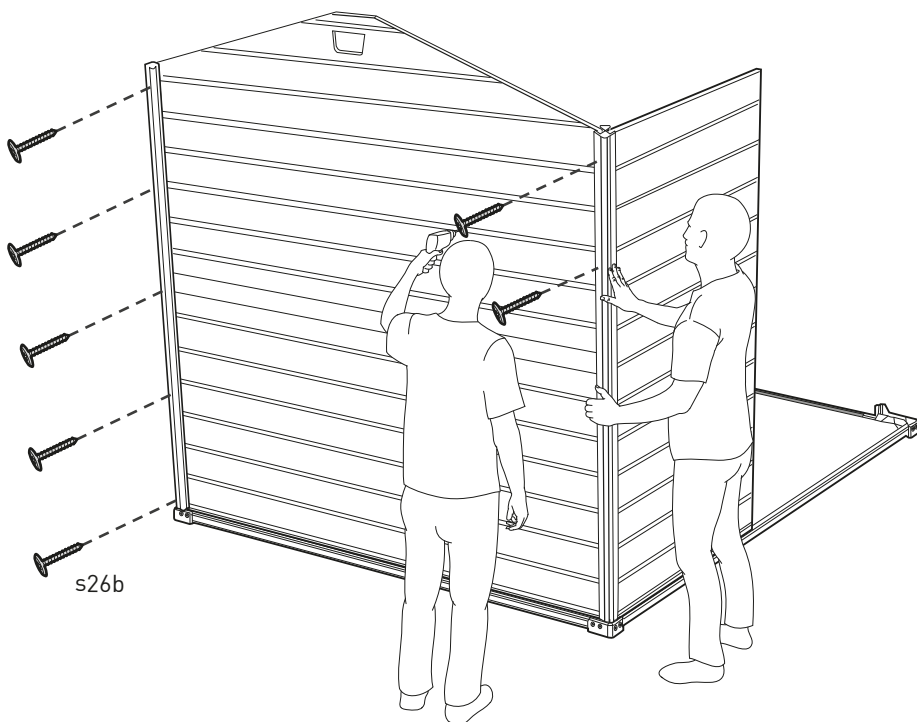

Wsunąć do końca panel w profile.

15

h1a (x1)
72.4"
184 cm

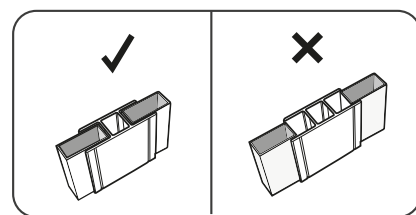
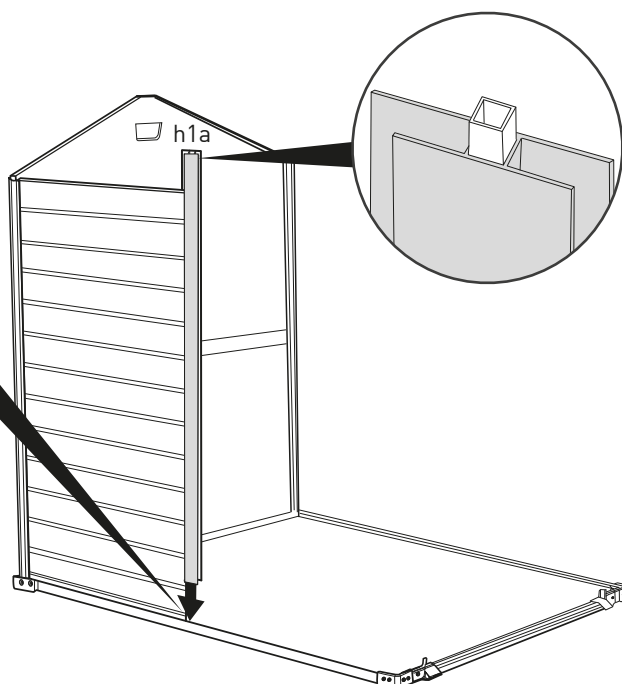
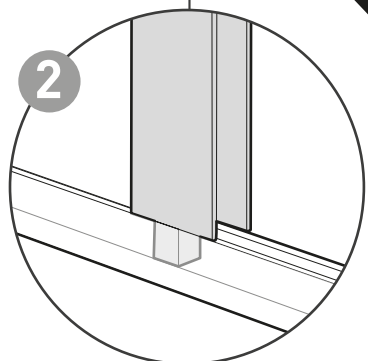
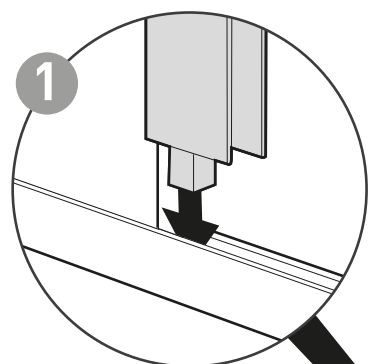

Wsunąć do końca panel w profile.

16

s1c (x1)
39.8" x 73.6"
101 x 187 cm

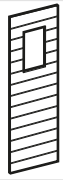

c1b (x1)
73.2"
186 cm

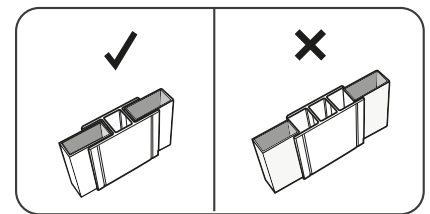
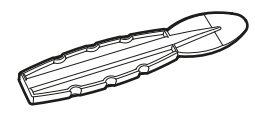
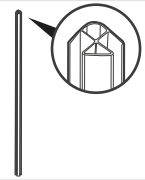

Wsunąć do końca panel w profile.

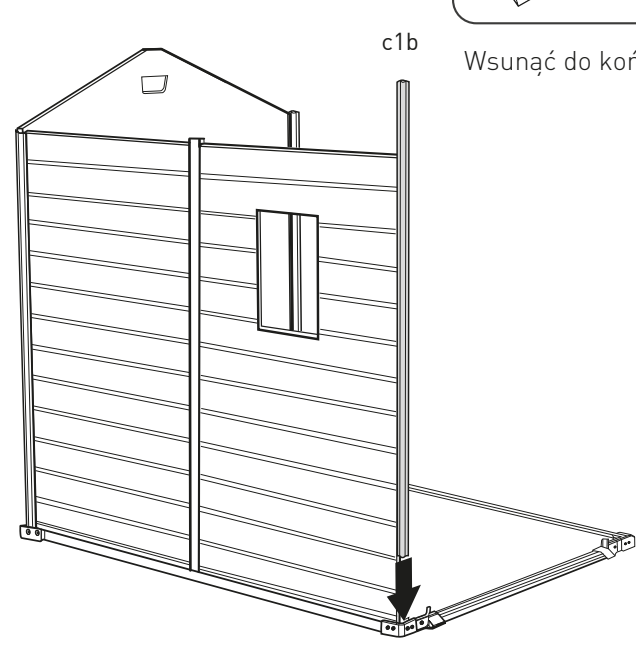
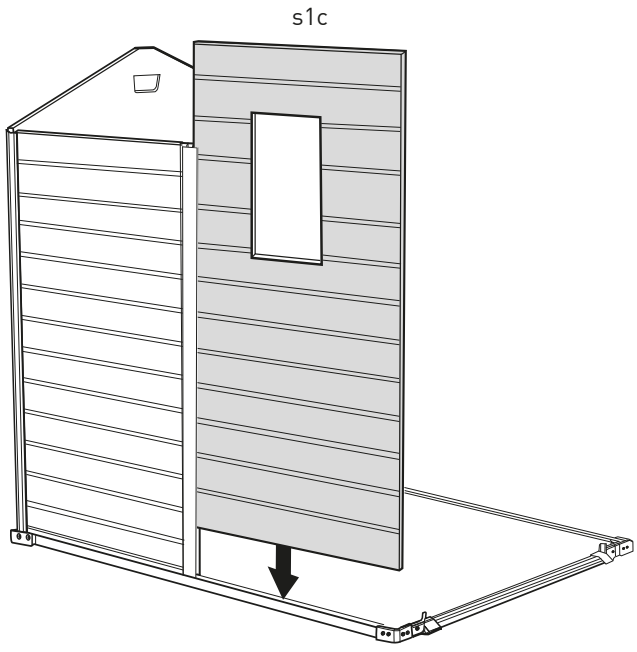

17

s13b (x2)
0.47"
12 mm

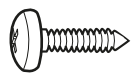

s26b (x5)
1"
26 mm

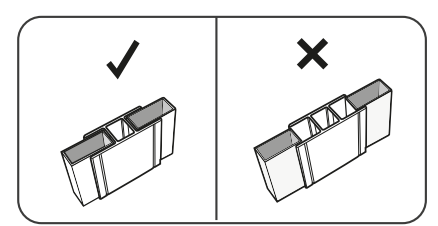

Wsunąć do końca panel w profile.

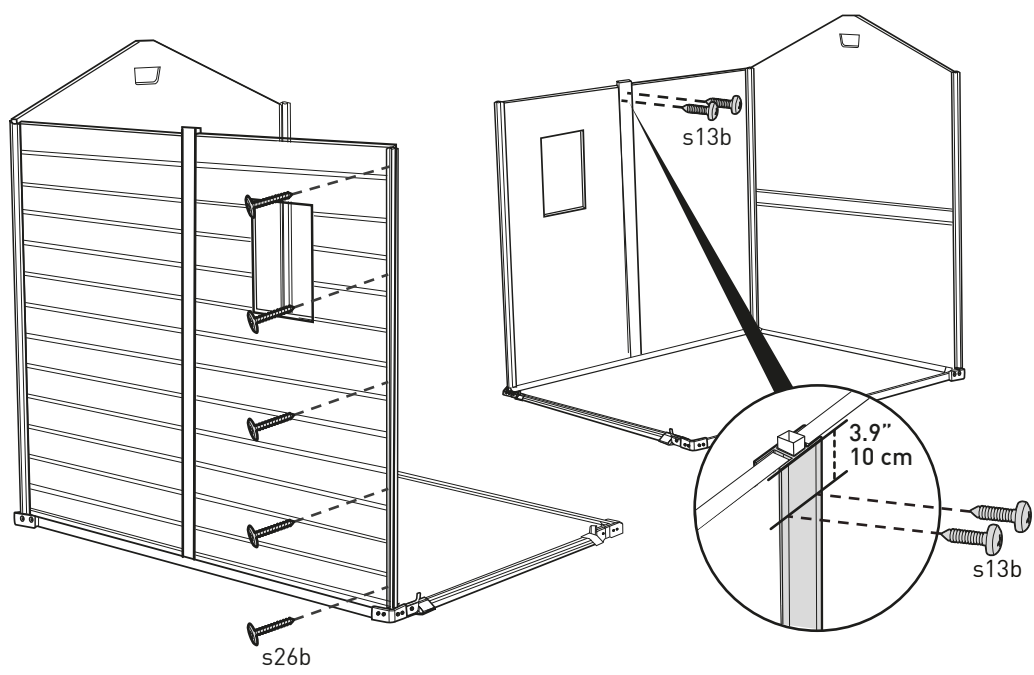

18

w1c (x1)
39.8" x 73.6"
101 x 187 cm

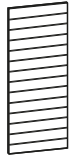

s26b (x5)
1"
26 mm

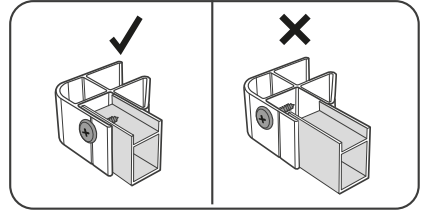
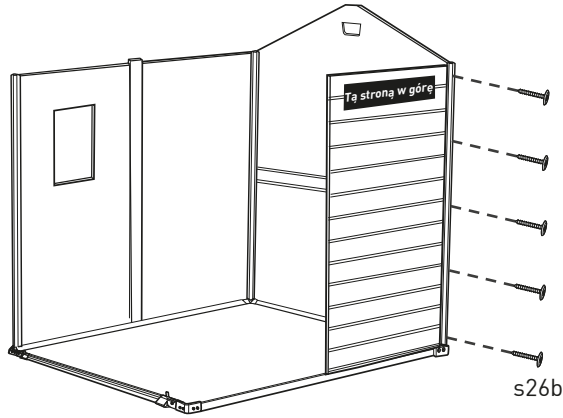
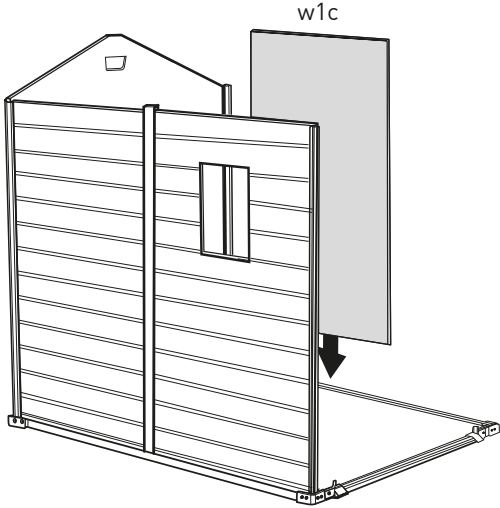
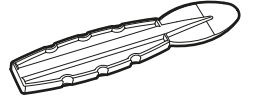
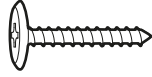

Wsunąć do końca panel w profile.

19

h1a (x1)
72.4"
184 cm



w1c (x1)
39.8" x 73.6"
101 x 187 cm

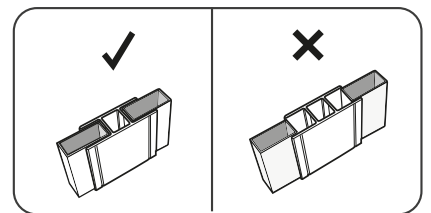
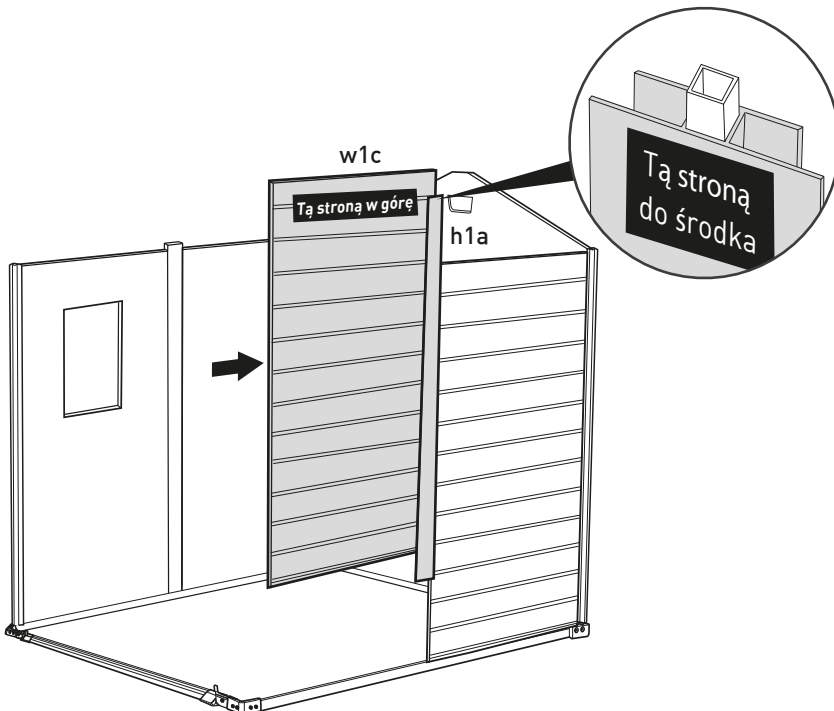
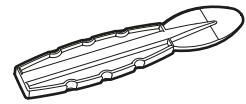

Wsunąć do końca panel w profile.

20

c1b (x1)
73.2"
186 cm

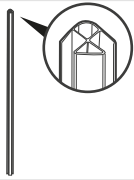

s13b (x2)
0.47"
12 mm

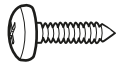

s26b (x5)
1"
26 mm

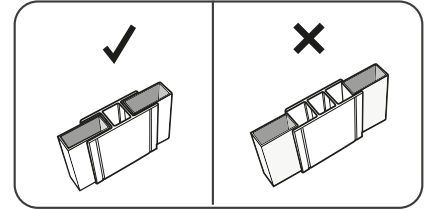
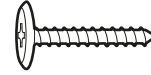

Wsunąć do końca panel w profile.

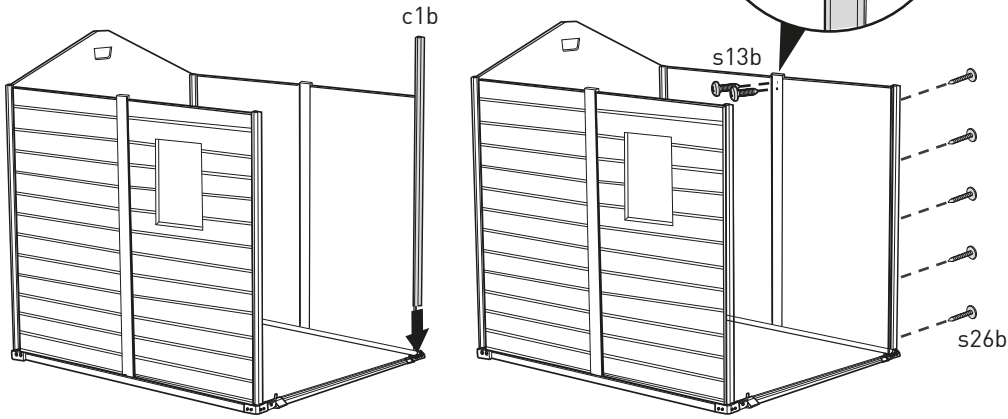

MONTAŻ ŚCIANY FRONTOWEJ ORAZ FRAMUGI

21

fd2b (x2)
6.7" x 51.5"
17 x 131 cm



s26b (x6)
1"
26 mm

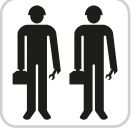
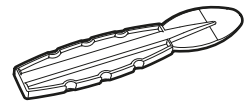
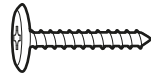

22

lm (x1)

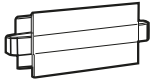

rm (x1)



Lewa

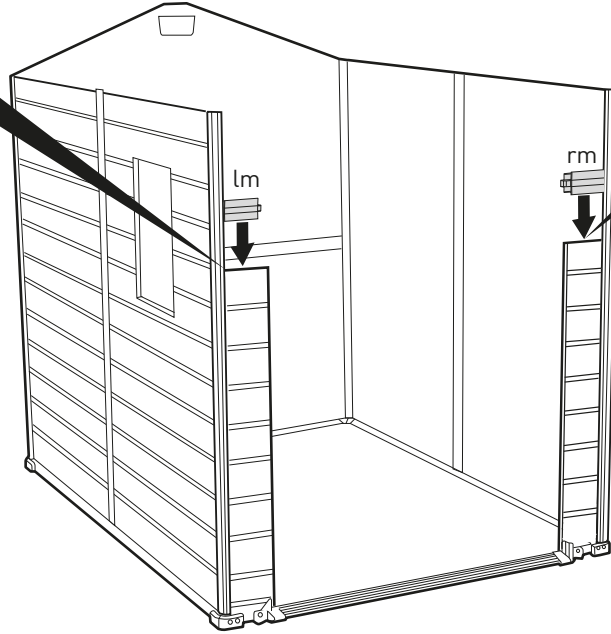
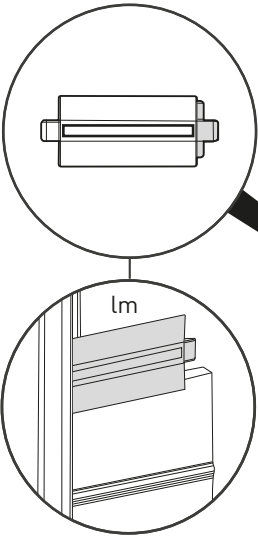

Prawa

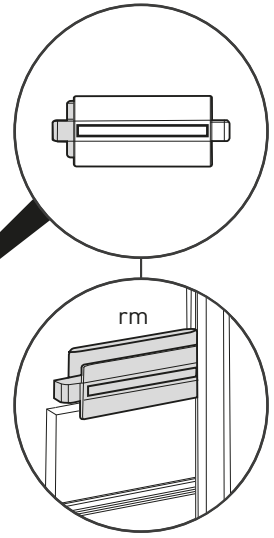

23

fu2a (x1)

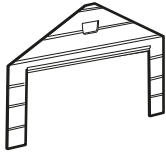

s26b (x4)
1"
26 mm

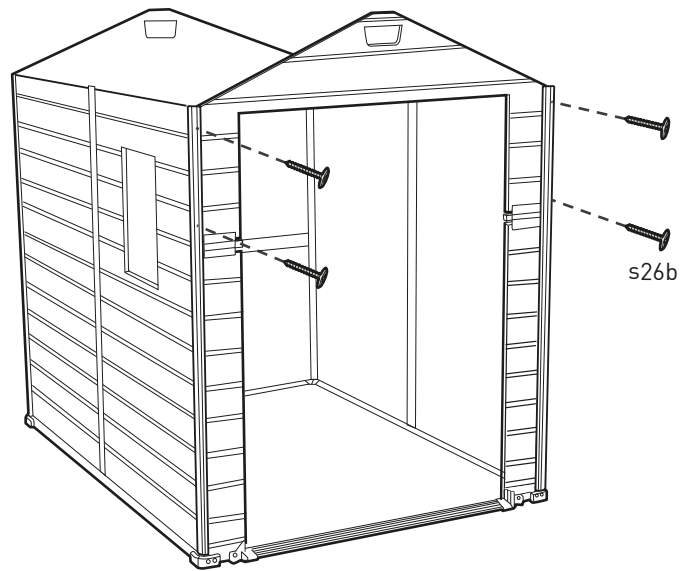
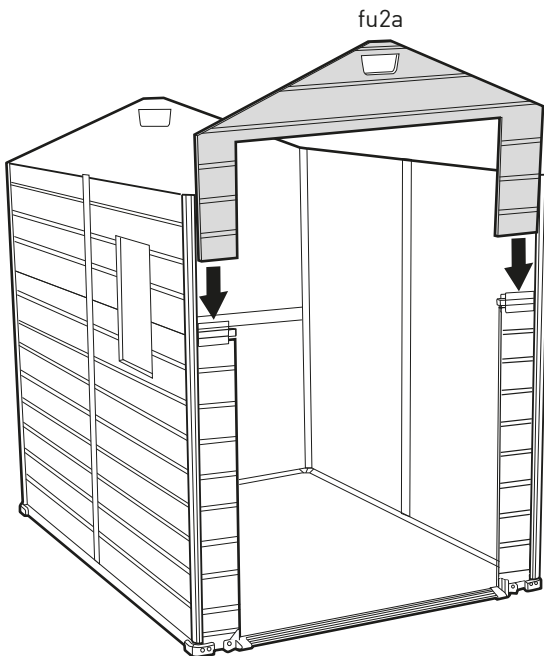
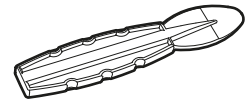

24

mdfl (x1)
70.4"
179 cm

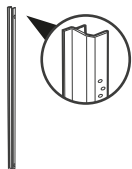

Nawiercane otwory

ds2b (x1)
0.39"
10 mm

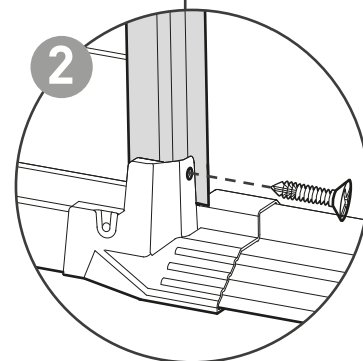
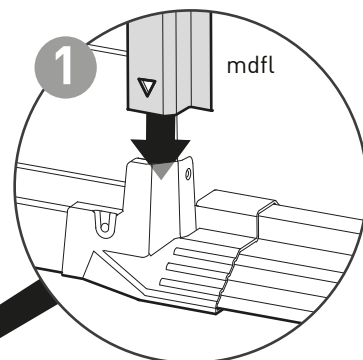
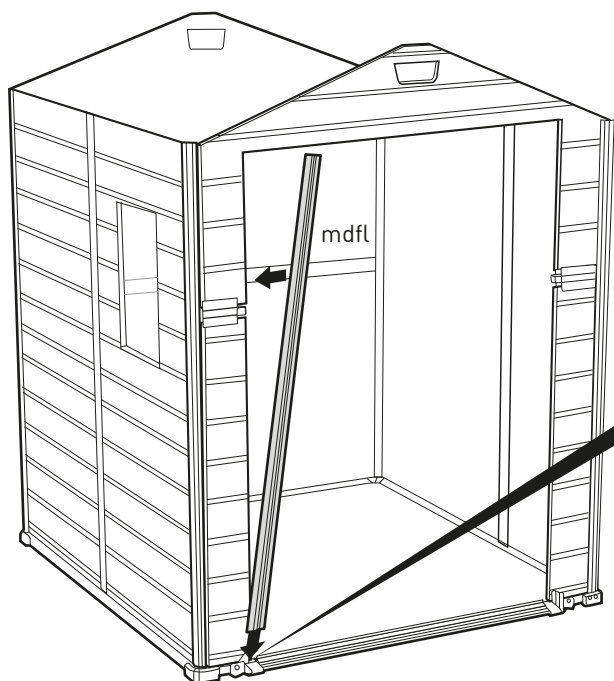

25

mdfr (x1)
70.4"
179 cm

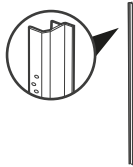

Wkręty
ds2b (x1)
0.39"
10 mm

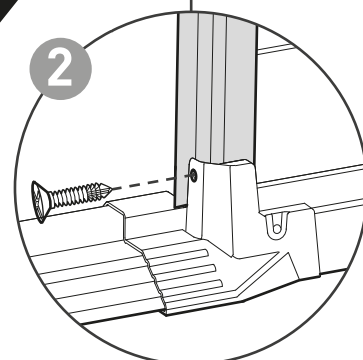
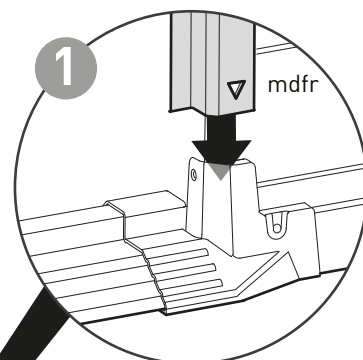
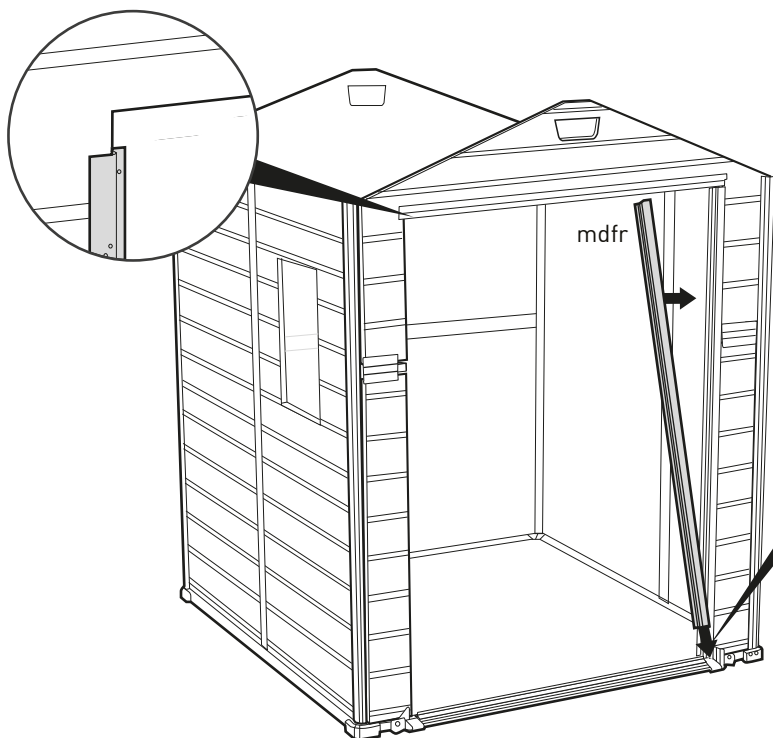

26

mtm (x1)
53.1"
135 cm

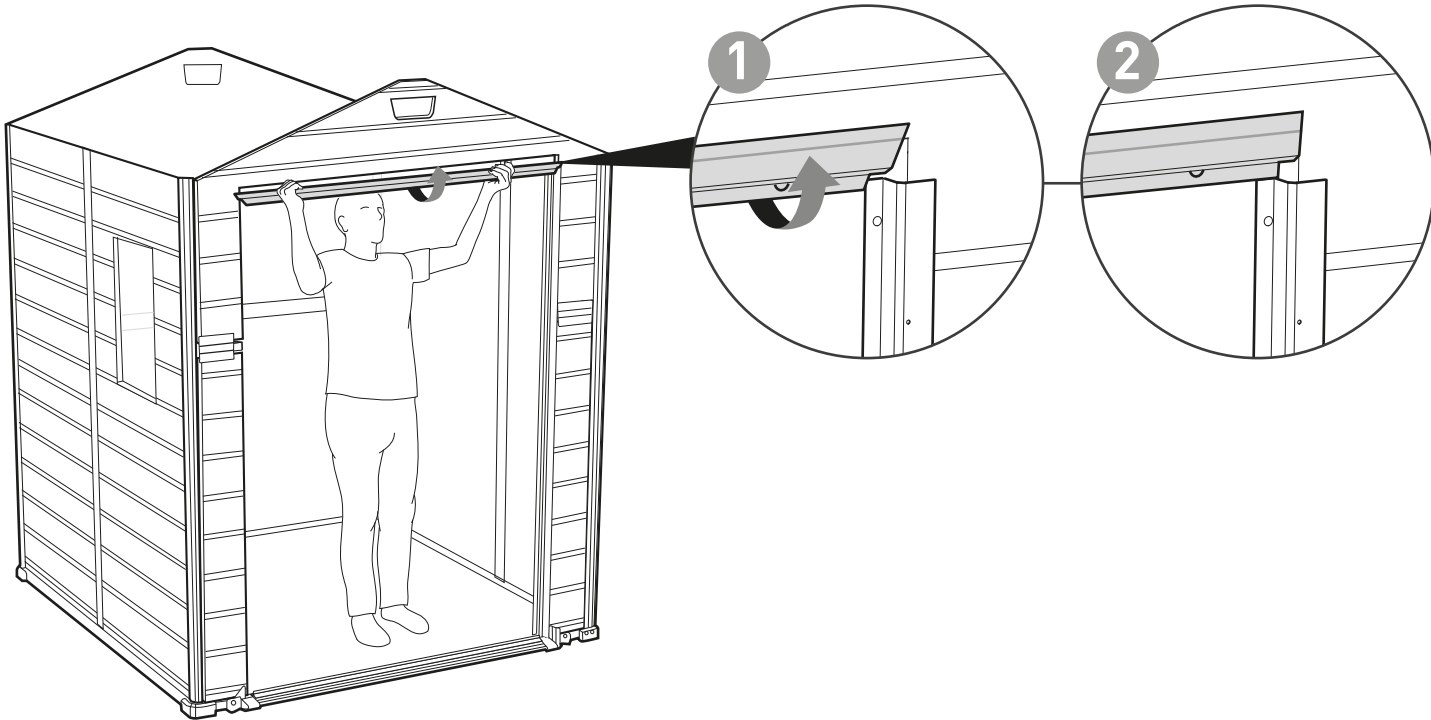

27

Wkręty
ds2b (x8)
0.39"
10 mm

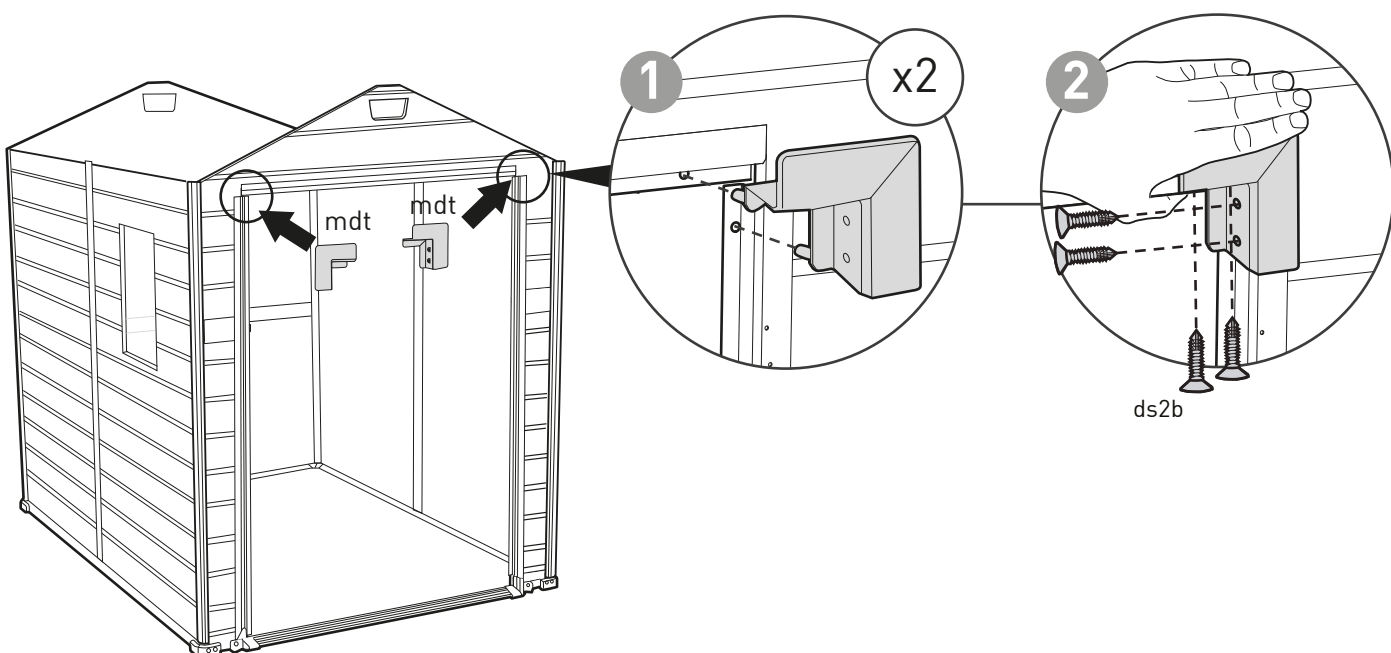

28

s50b (x2)
1.97"
50 mm

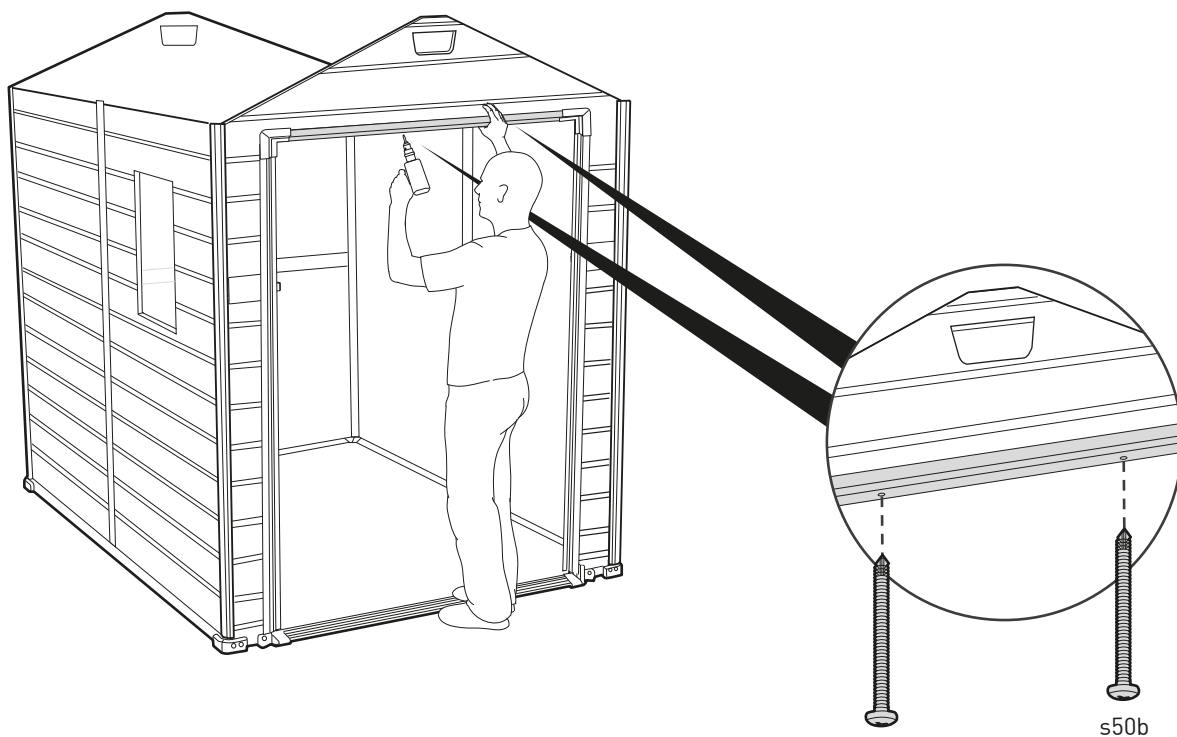

s50b

29

Wkręty
s10b (x8)
0.47"
12 mm

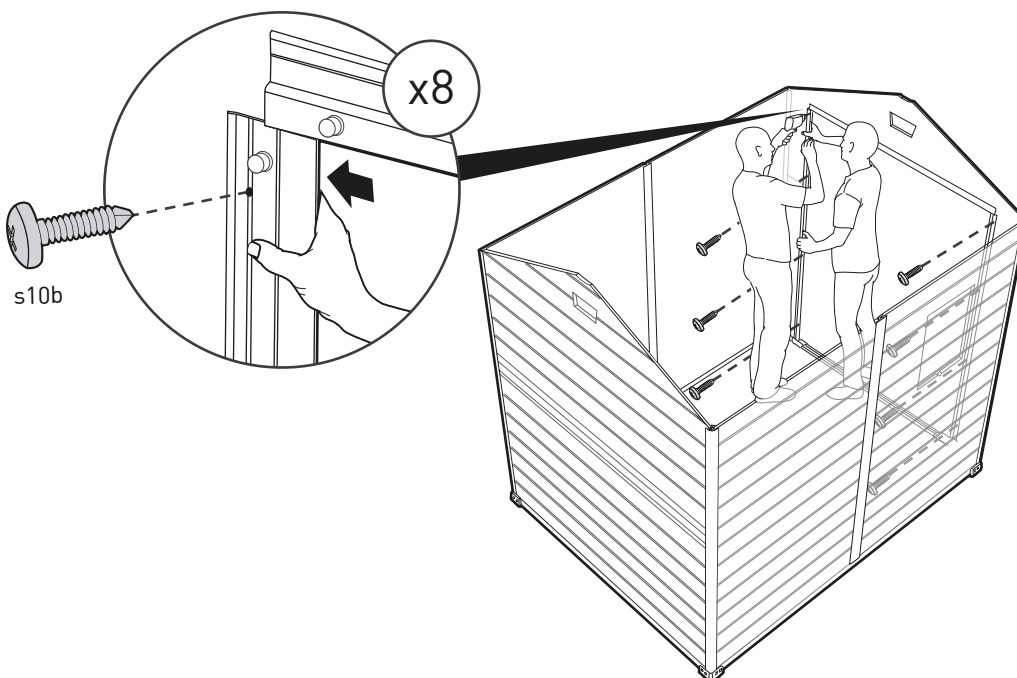
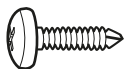

x8

s10b

30

s26b (x16)
1"
26 mm

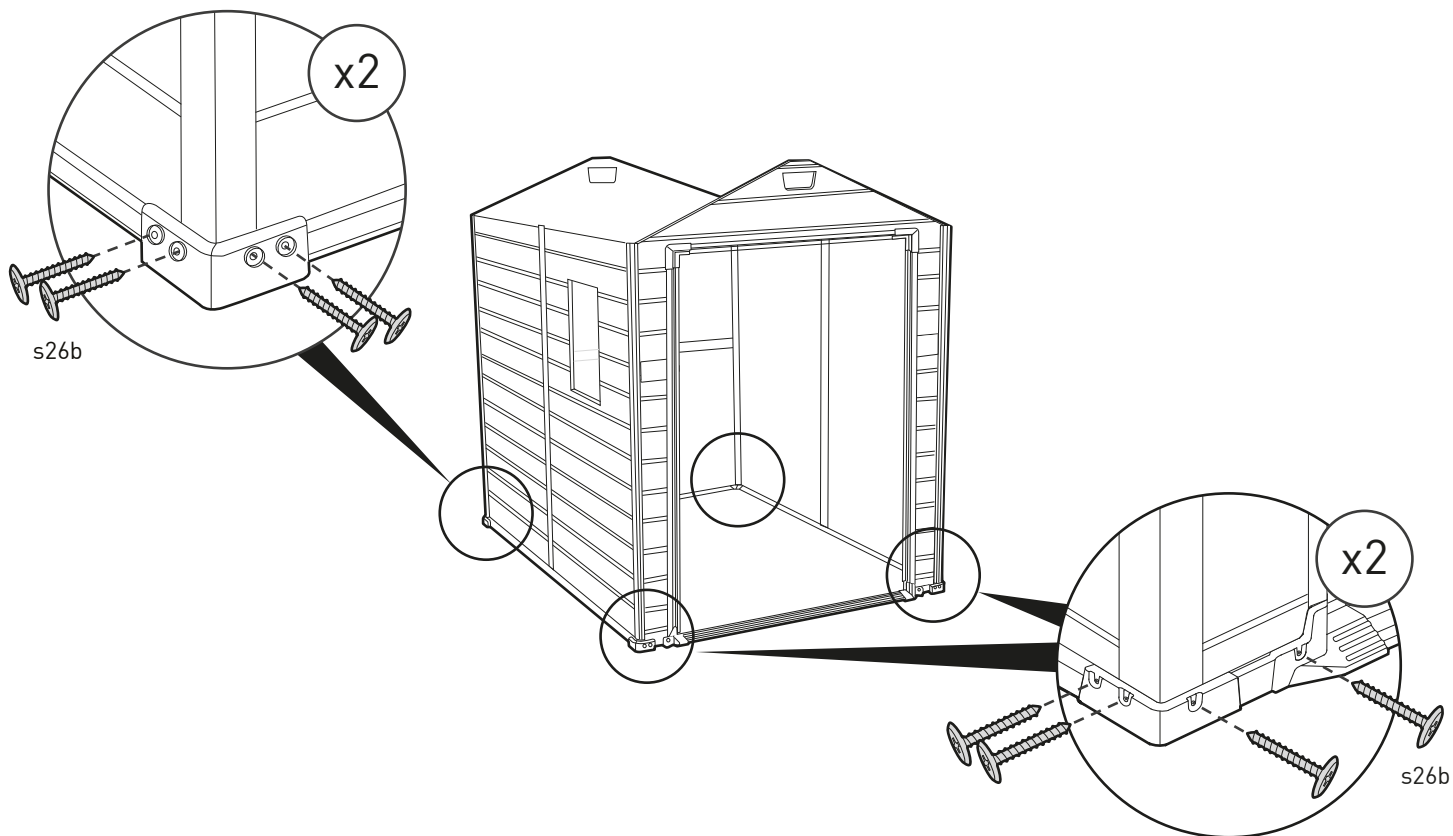

31

s26b (x12)
1"
26 mm

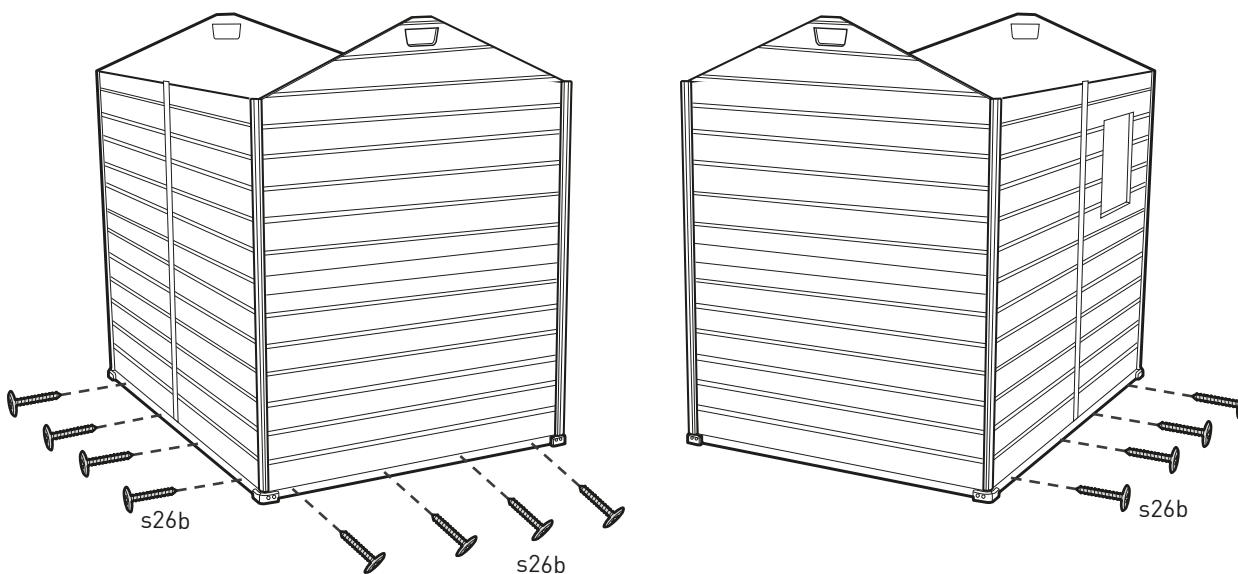

MONTAŻ DACHU

32

s26b (x4)
1"
26 mm



b1a (x1)
90.5"
230 cm

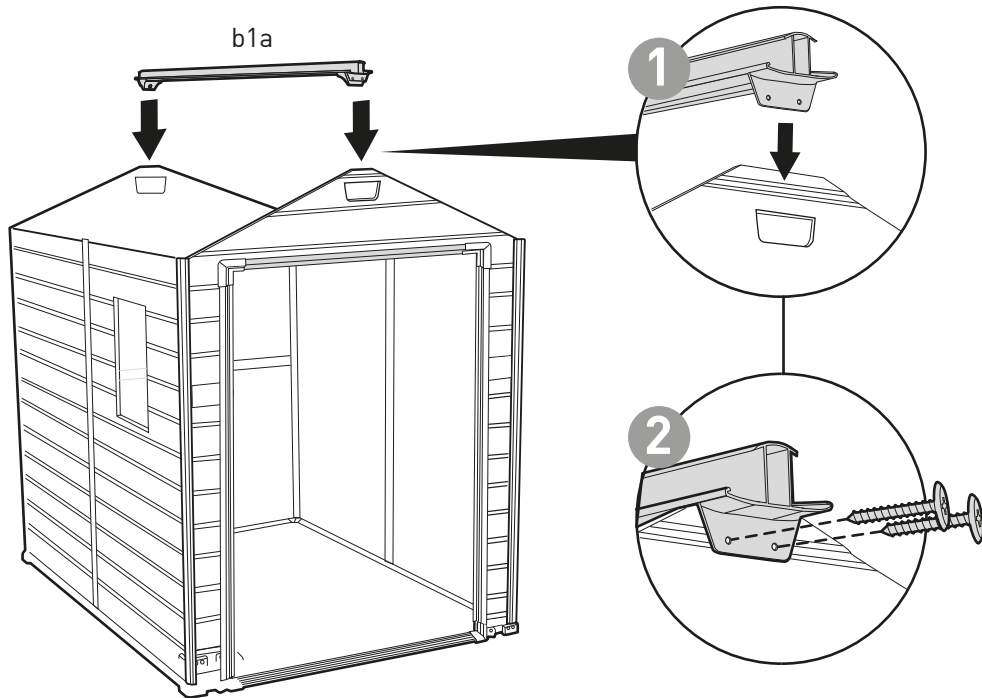

33

r1h (x1)
76.7" x 91.3"
195 x 232 cm

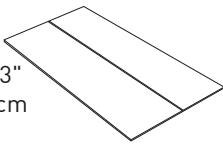

e1e (x2)
85"
216 cm



e1g (x4)
33"
84 cm



rc (x4)



- **Uwaga:** Linia zgięcia dachu i naklejka z napisem „Tą stroną w dół” musi być skierowana do góry jak na przedstawionym poniżej rysunku.

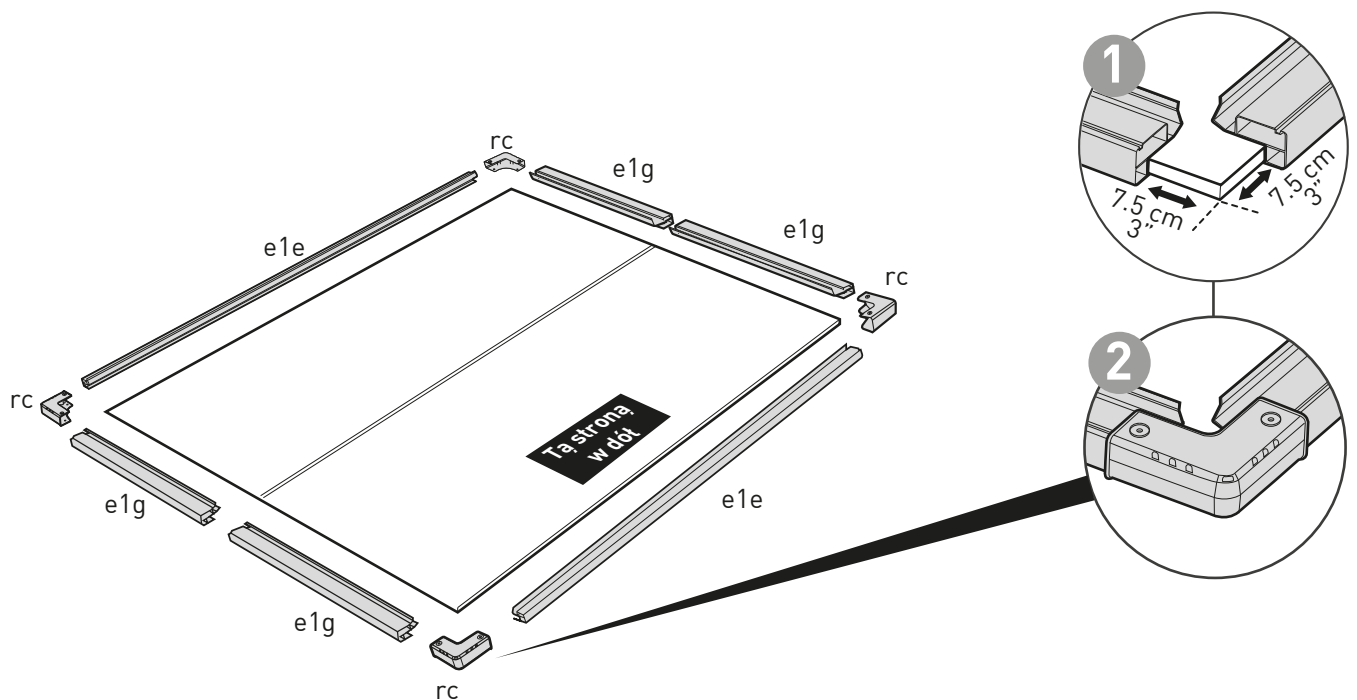

34

s26b (x8)
1"
26 mm

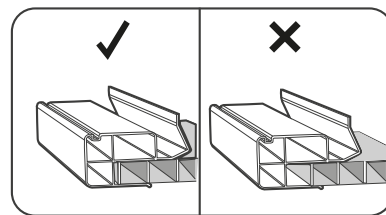
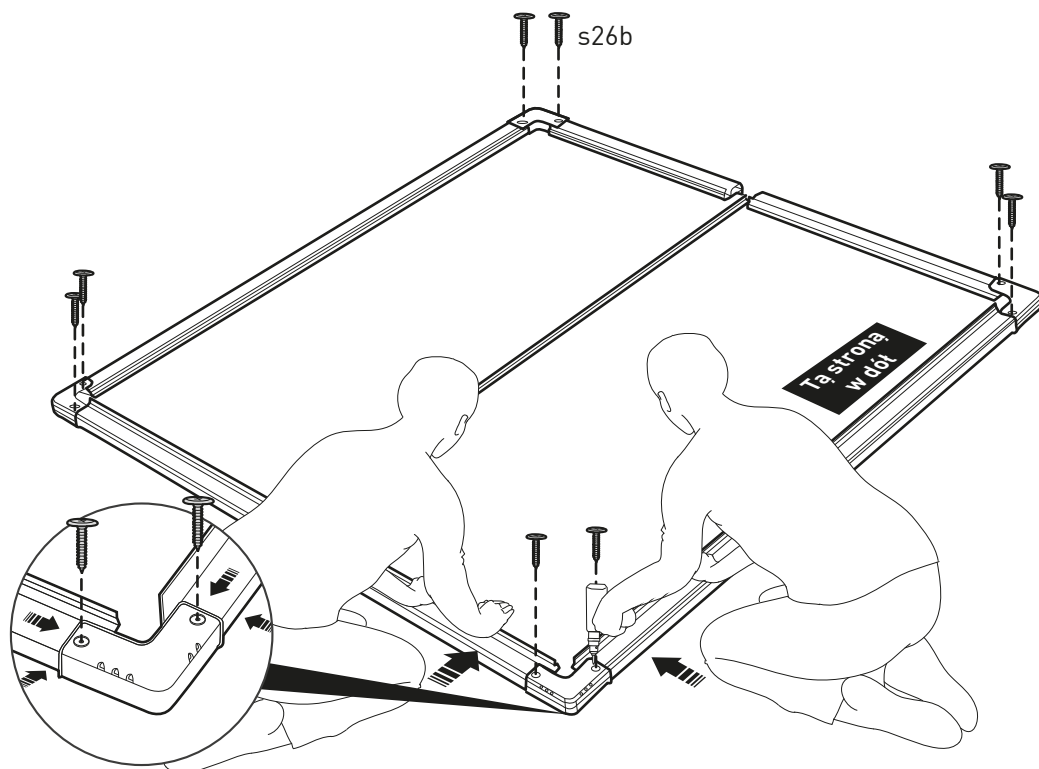

Wsunąć do końca panel
w profile.

35

Obrócić panel dachowy.

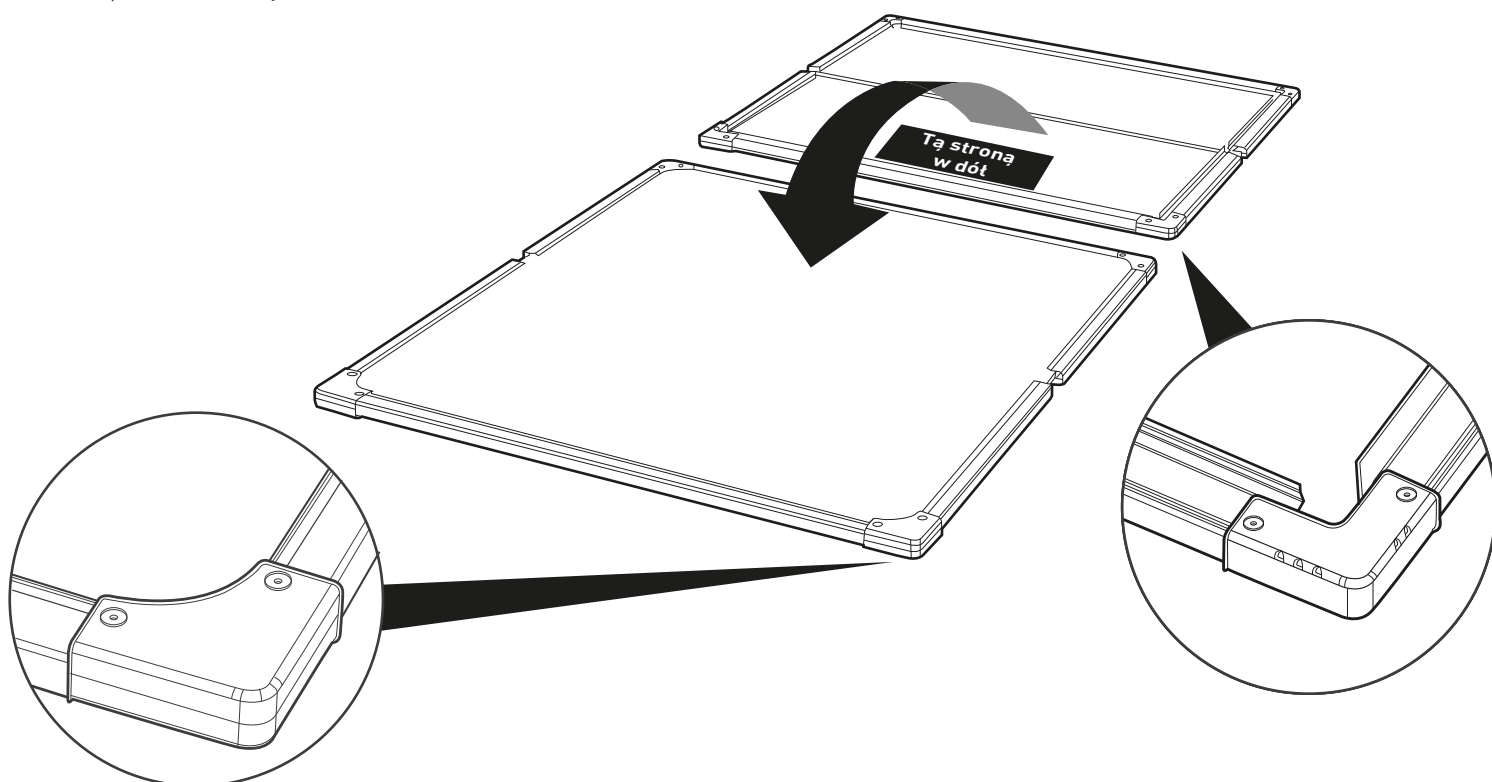

36

s26b (x24)
1"
26 mm

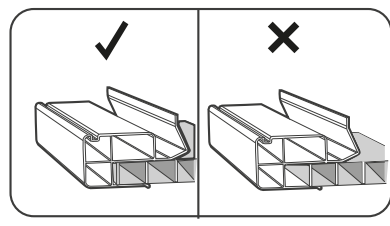
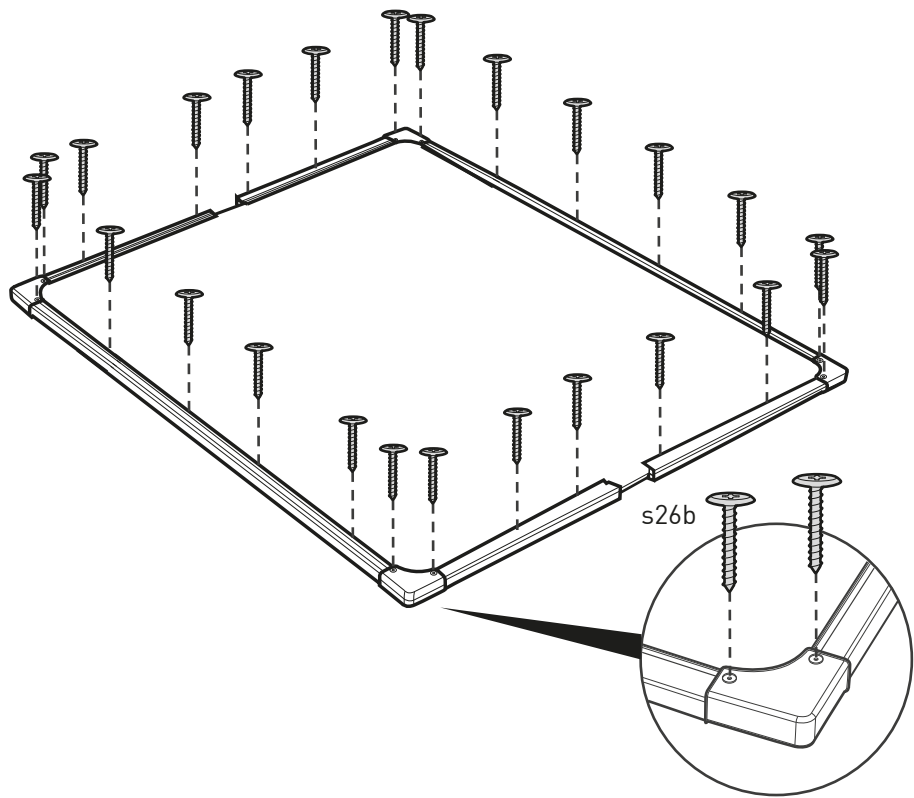

Wsunąć do końca panel w profile.

37

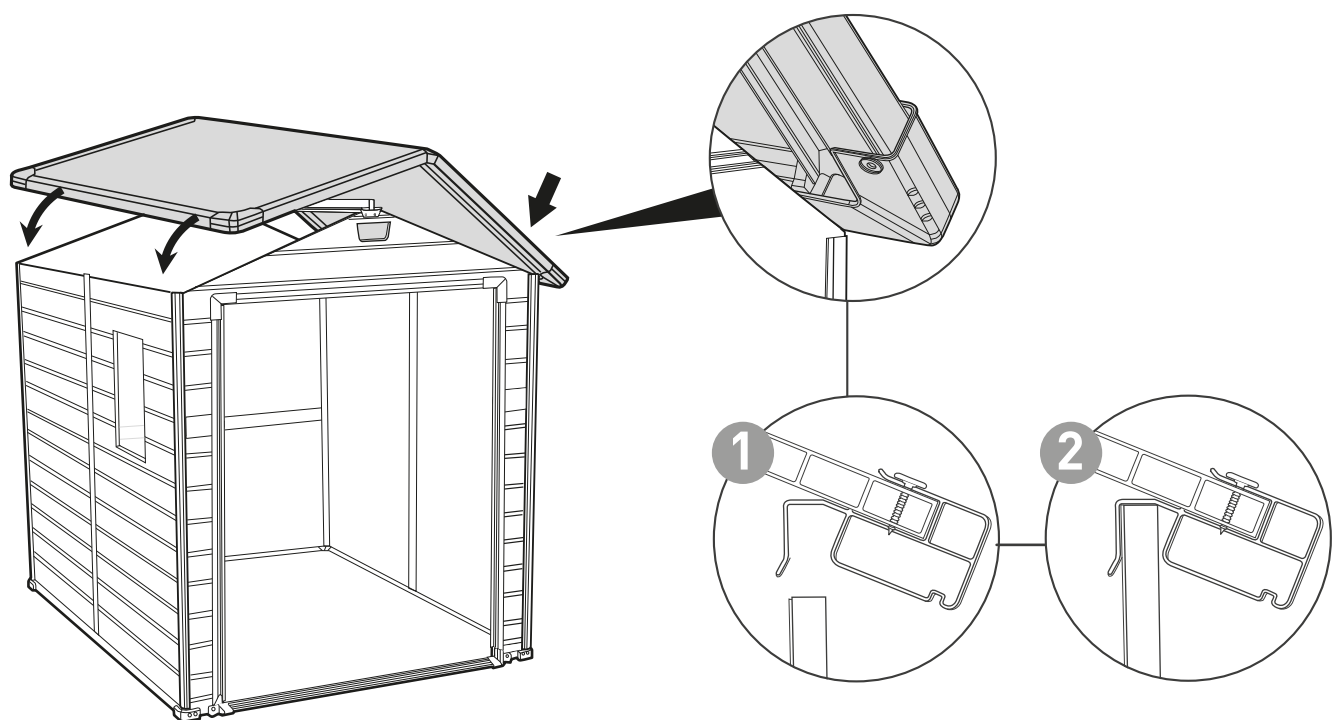
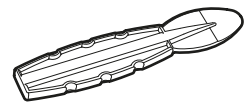
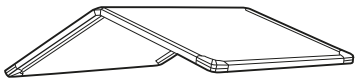

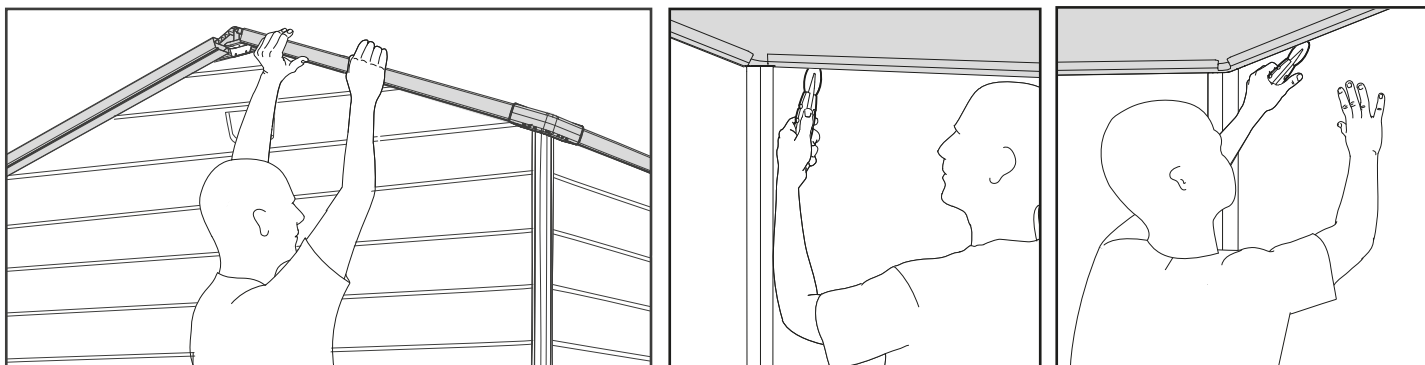
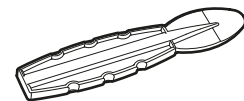

- Należy upewnić się, czy dach został dokładnie osadzony. Można użyć szpatułki jak na przedstawionym rysunku.

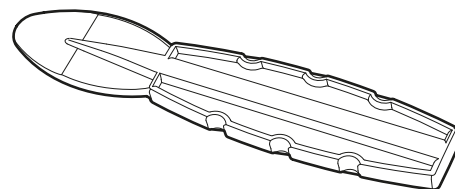

ac (x2)



ap (x1)

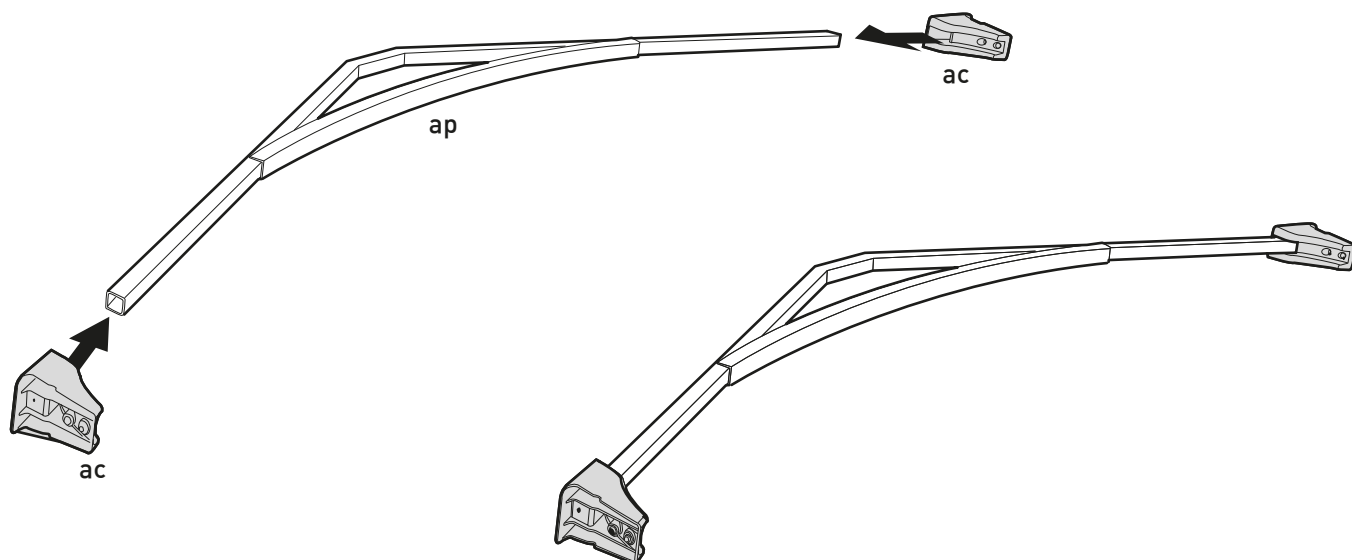

40

Wkręty
s23b (x4)
0.98"
25 mm



Podpora dachowa

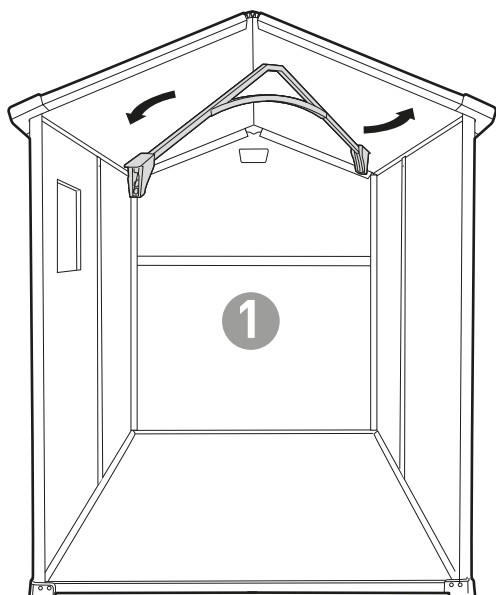
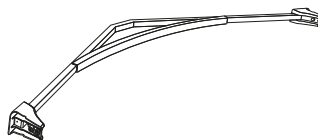

- Ustaw podporę dachu we właściwej pozycji.

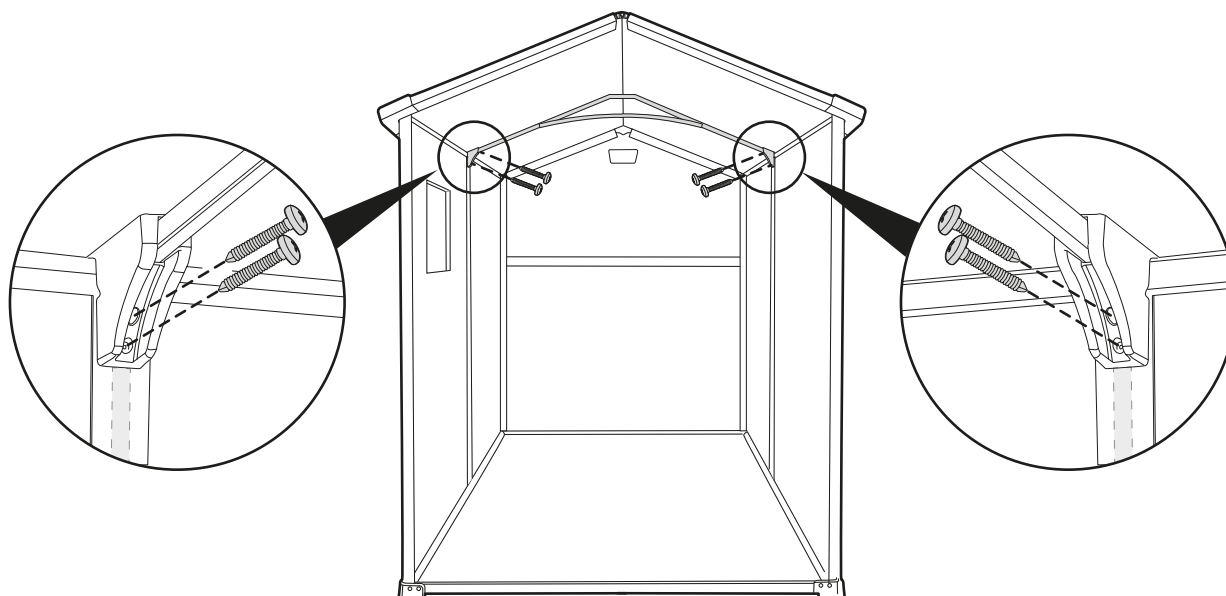
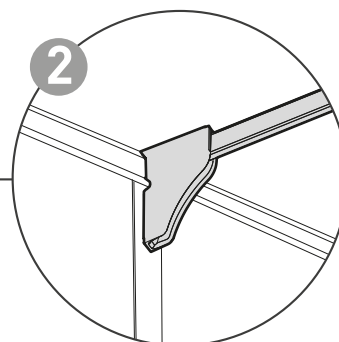
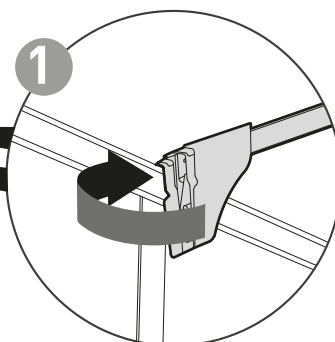
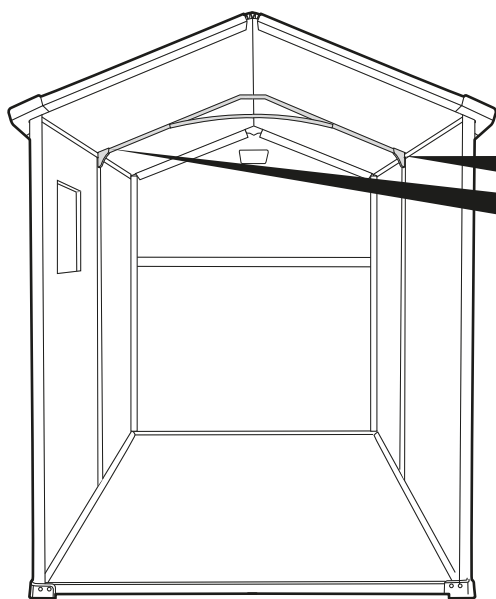
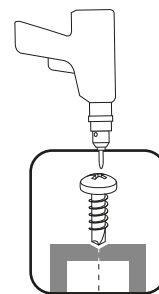

41

sh



s26b (x4)
1"
26 mm

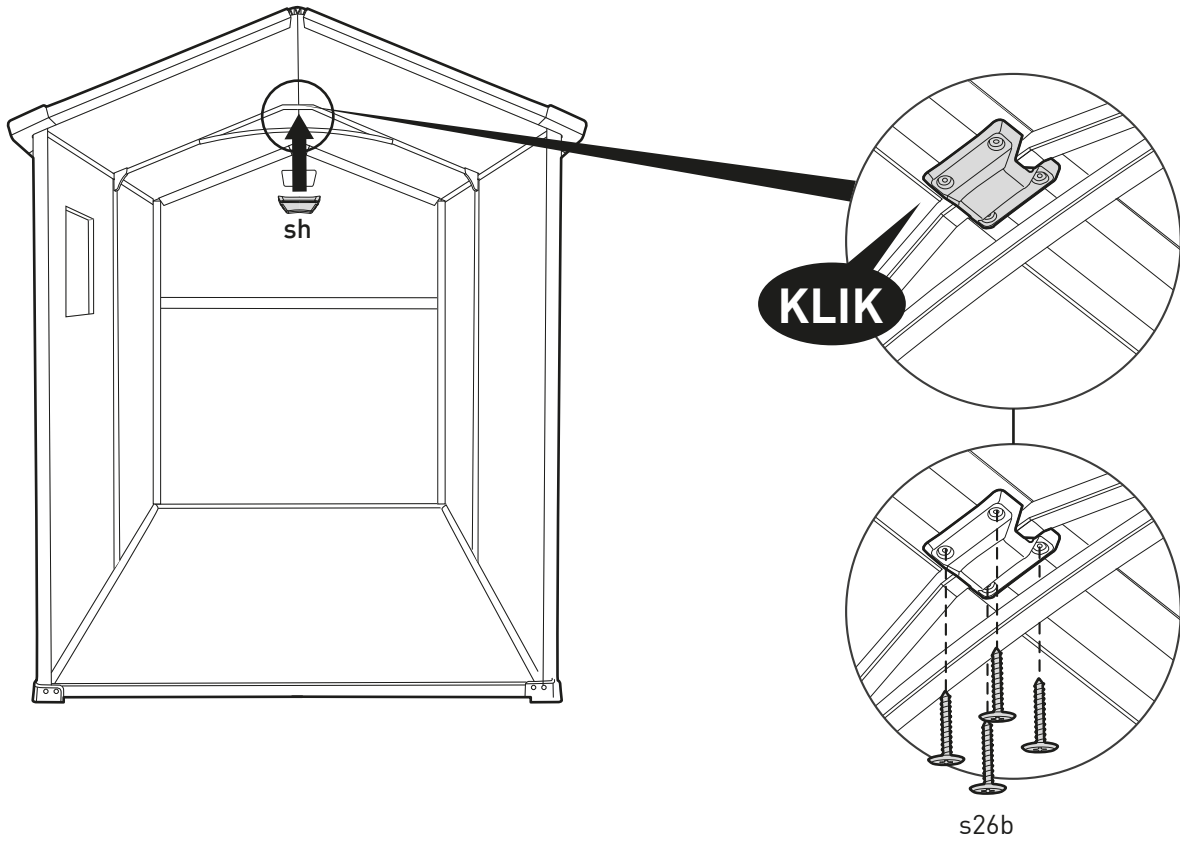
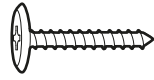

42

s26b (x16)
1"
26 mm

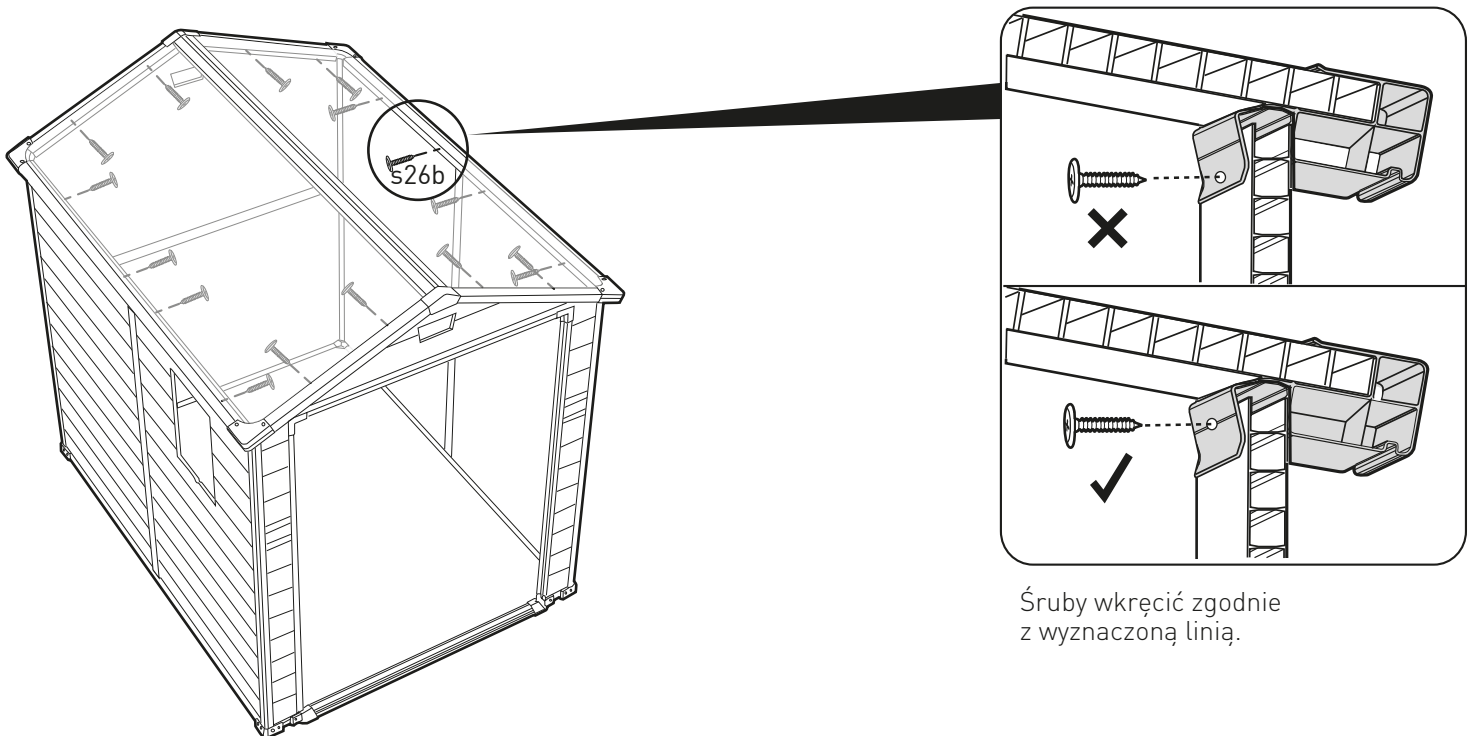
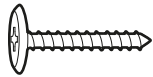

MONTAŻ DRZWI

43

mdd (x2)

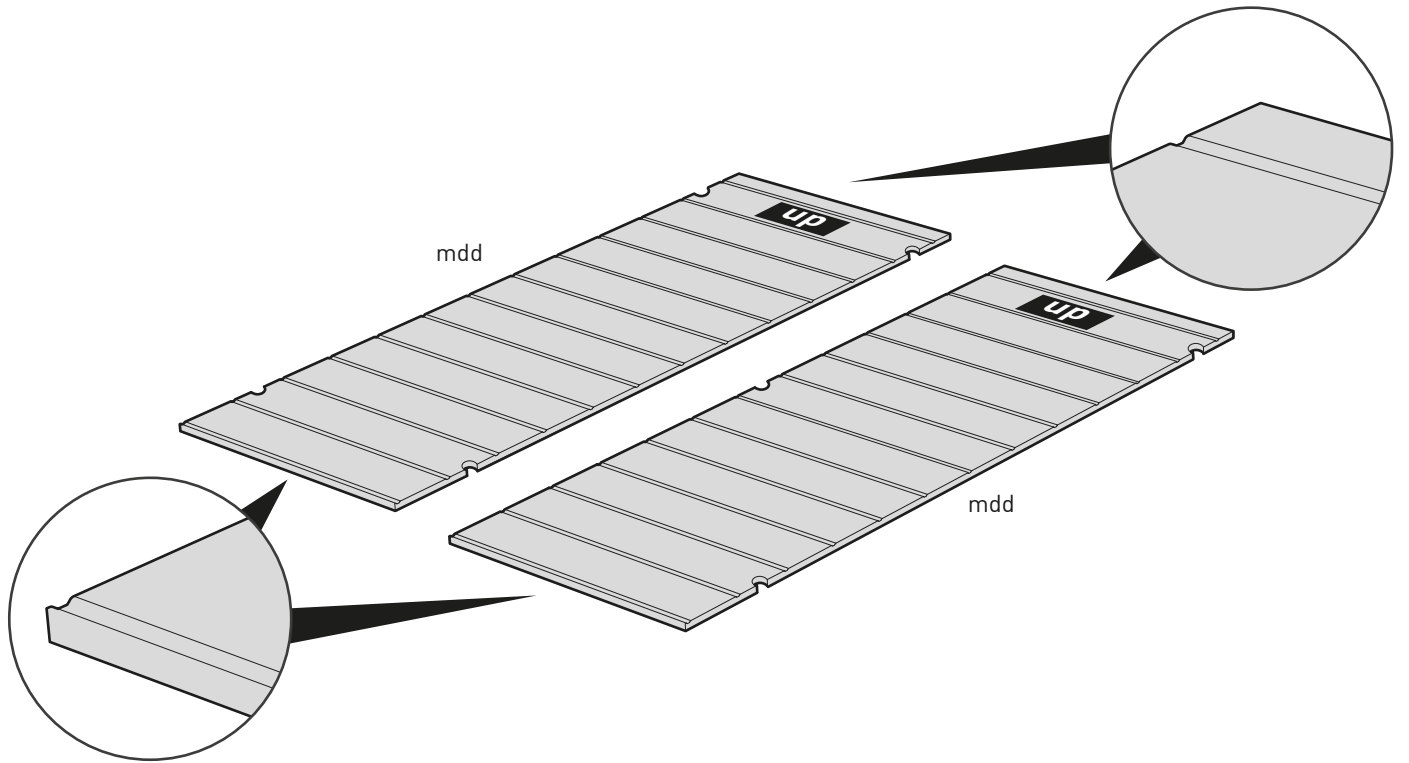
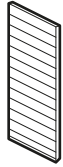

44

mdd (x2)

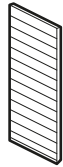

dc (x5)

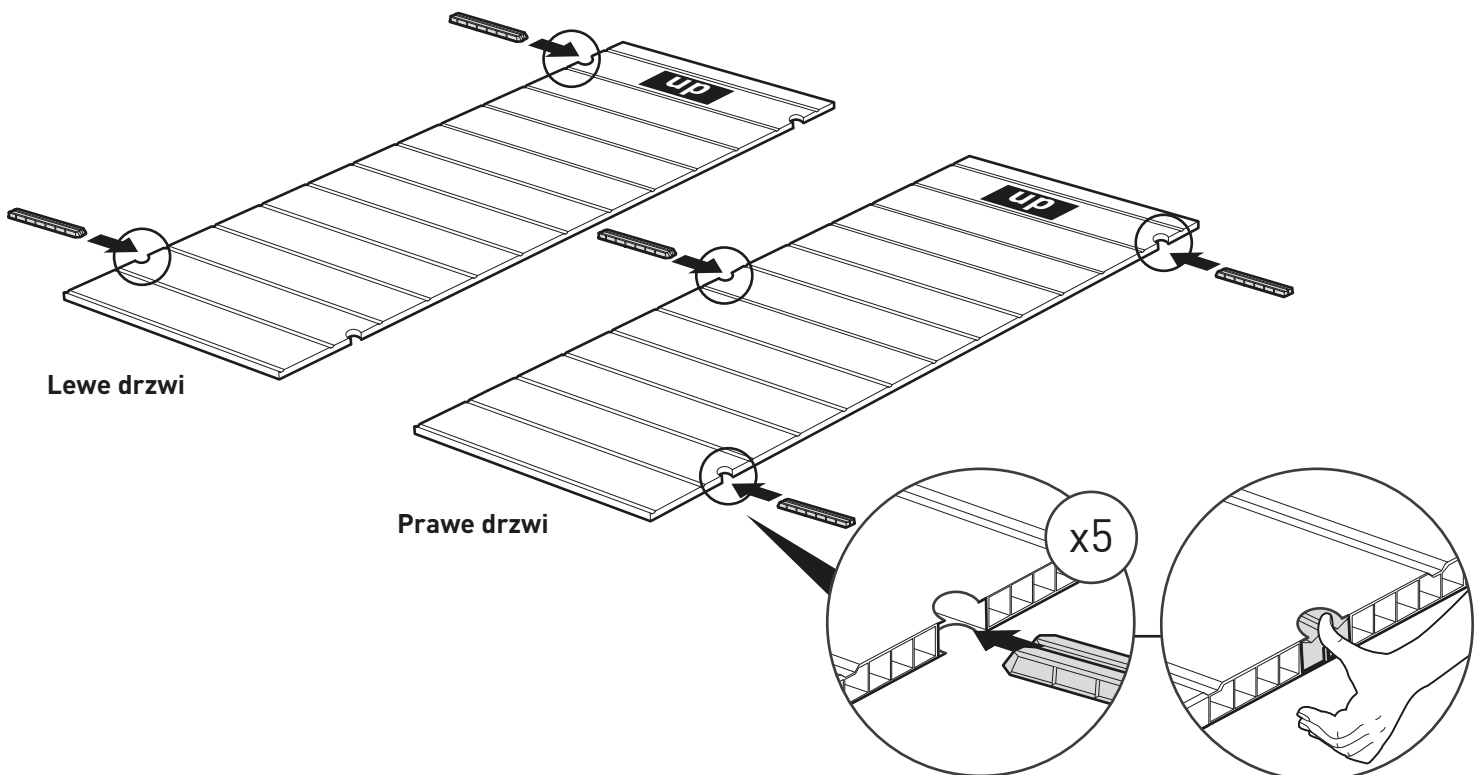
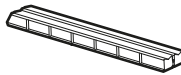

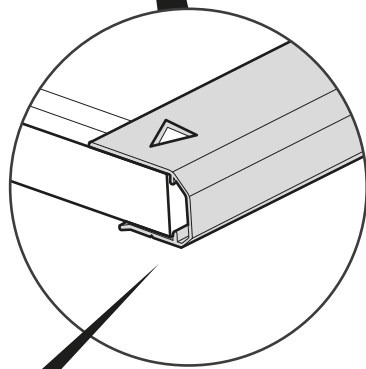
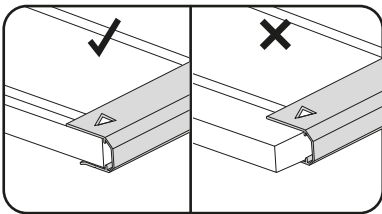
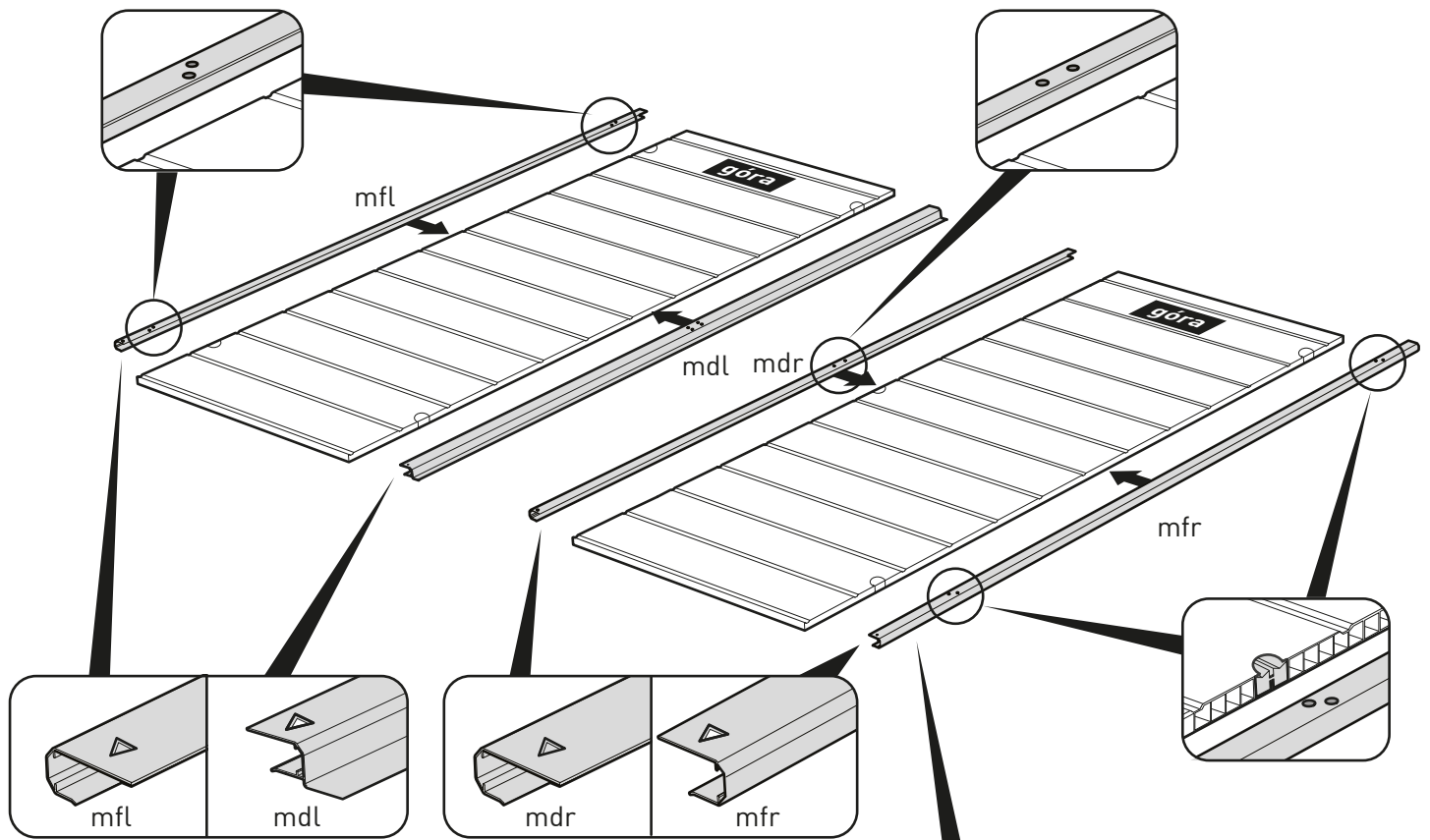
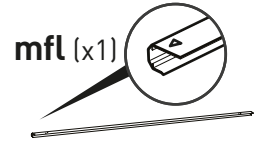
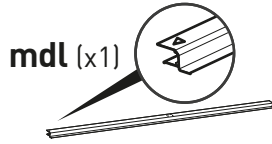
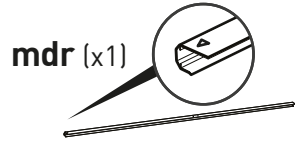
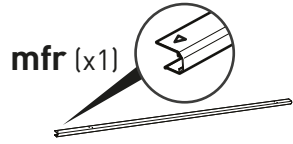

• Wyrównać krawędź profilu aluminiowego z krawędzią panelu drzwi.

46

ldd (x2)

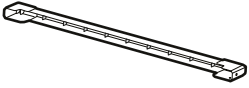

rdd (x2)

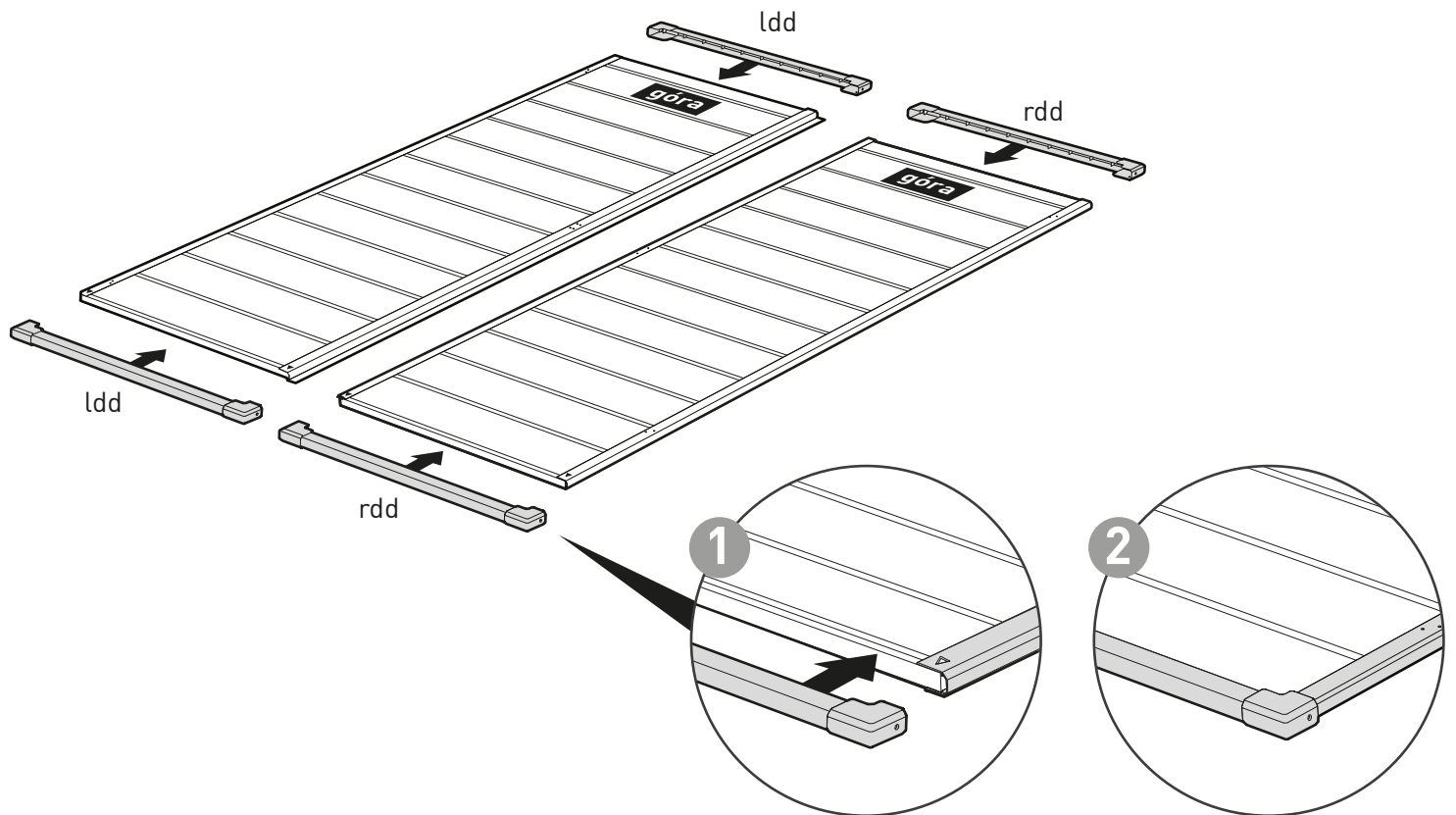
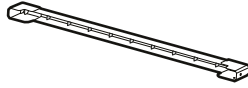

47

- Obrócić panel drzwiowy

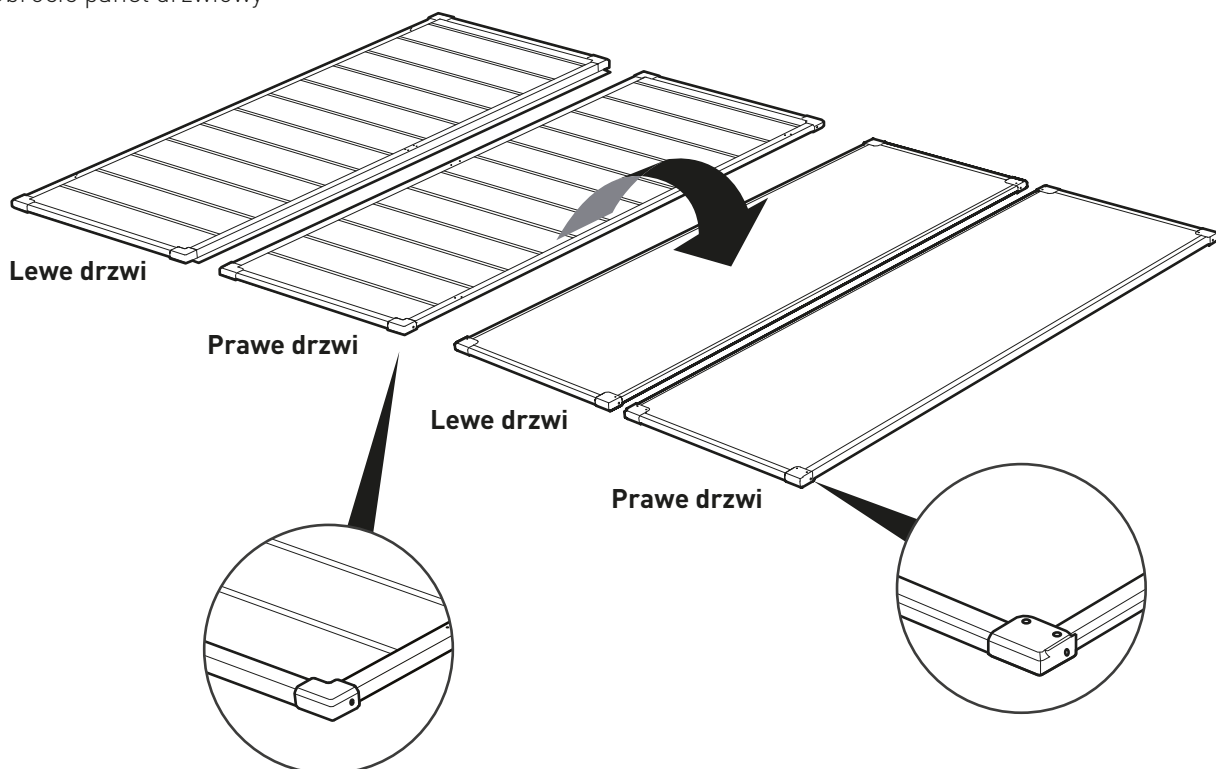

48

Wkręty
ds2b (x8)
0.39"
10 mm

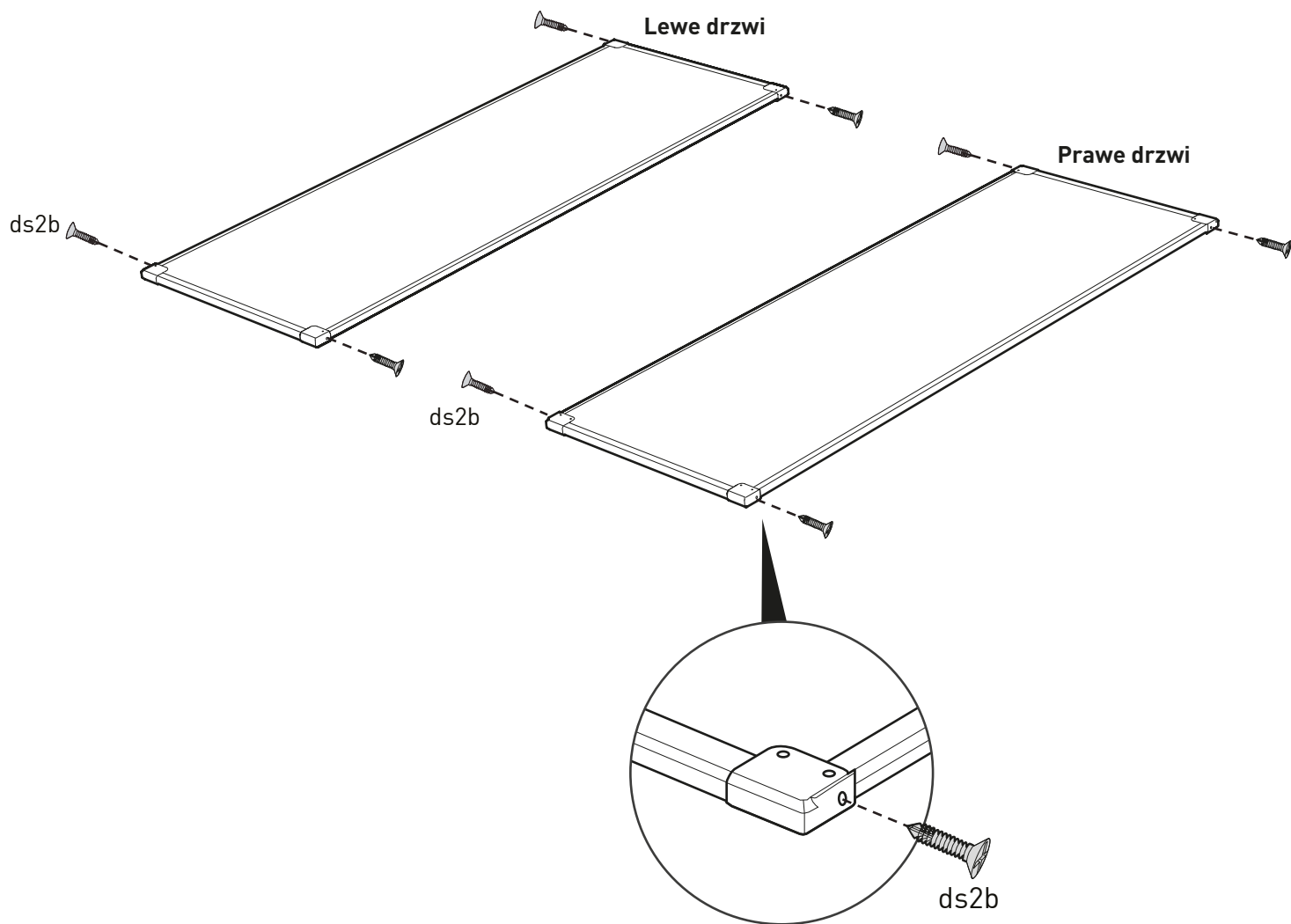

49

Wkręty
s10b (x20)
0.47"
12 mm

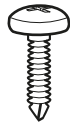

mpn (x2)

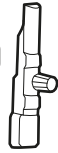

mtl (x1)

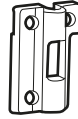

mbL (x1)

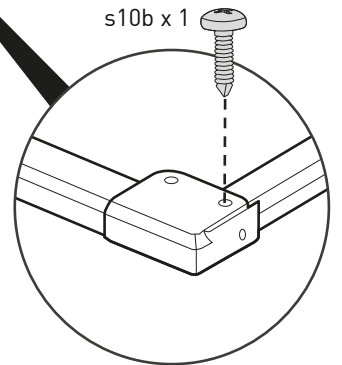
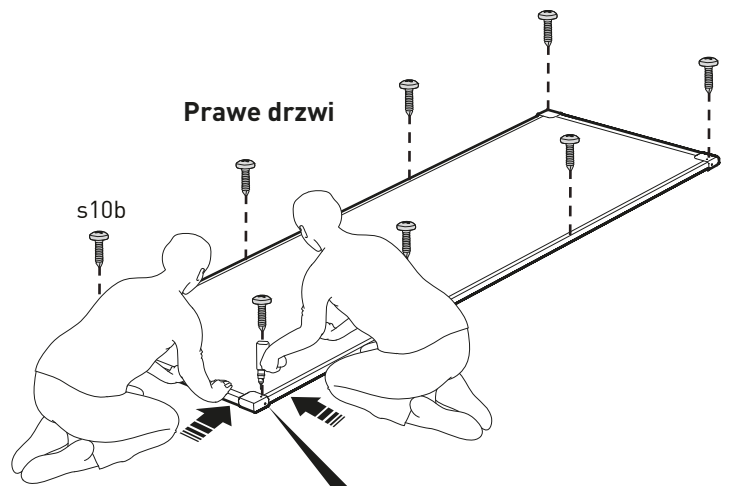
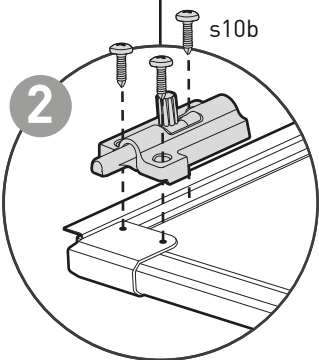
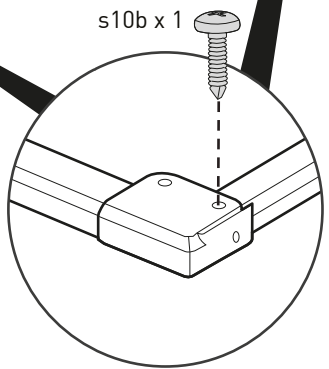
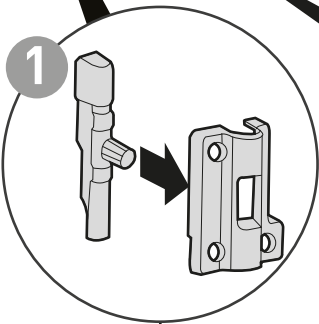
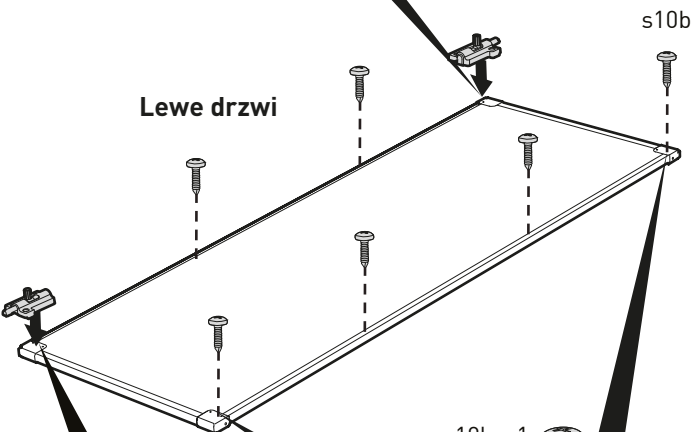
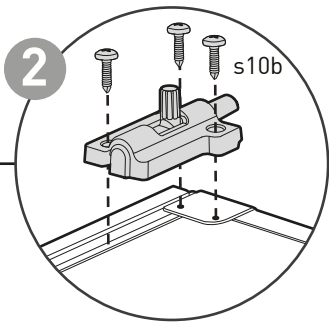
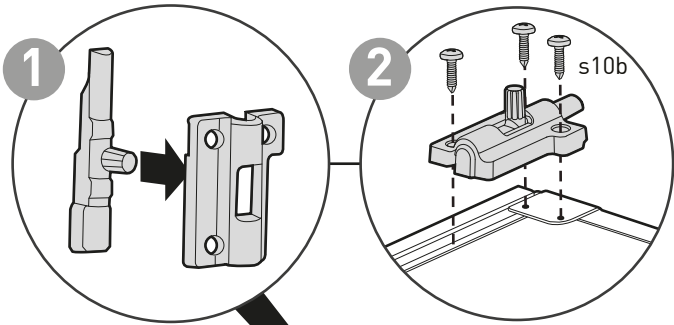
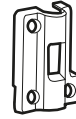

50

dh (x4)

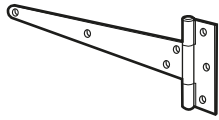

s13b (x28)
0.47"
12 mm

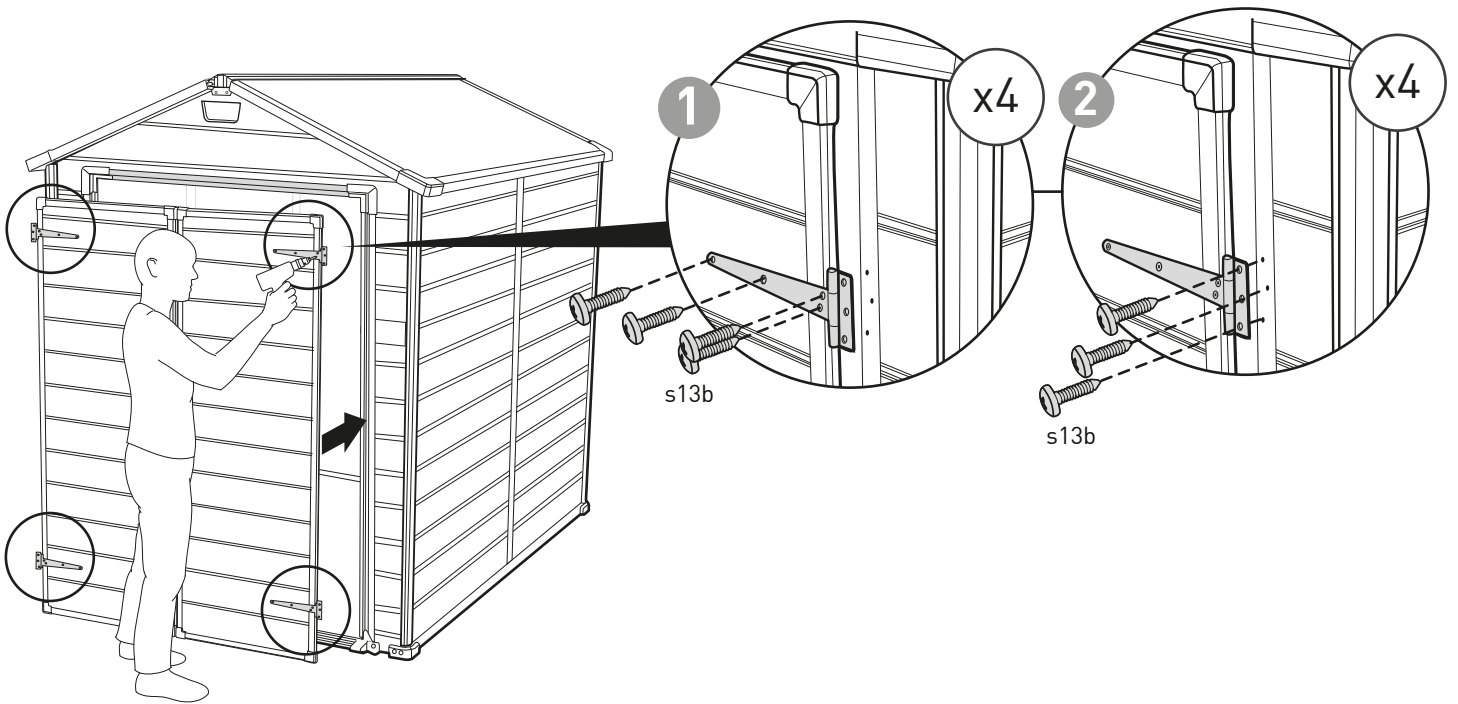
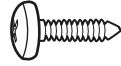

51

db1 (x1)

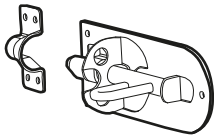

s13b (x7)
0.47"
12 mm

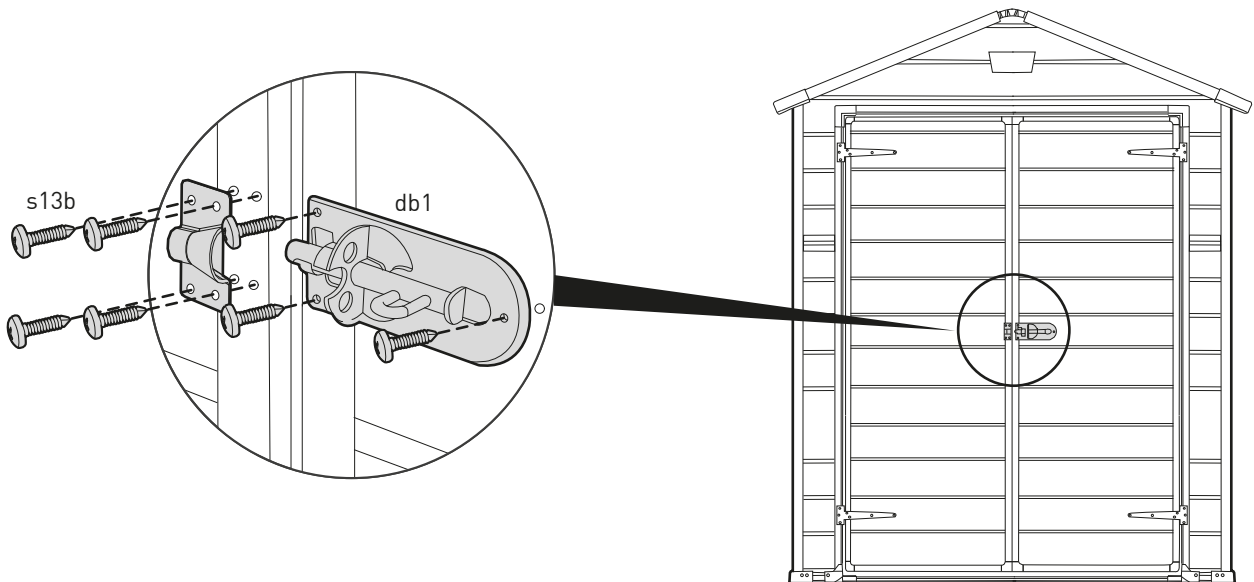
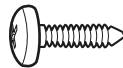

52

V (x2)

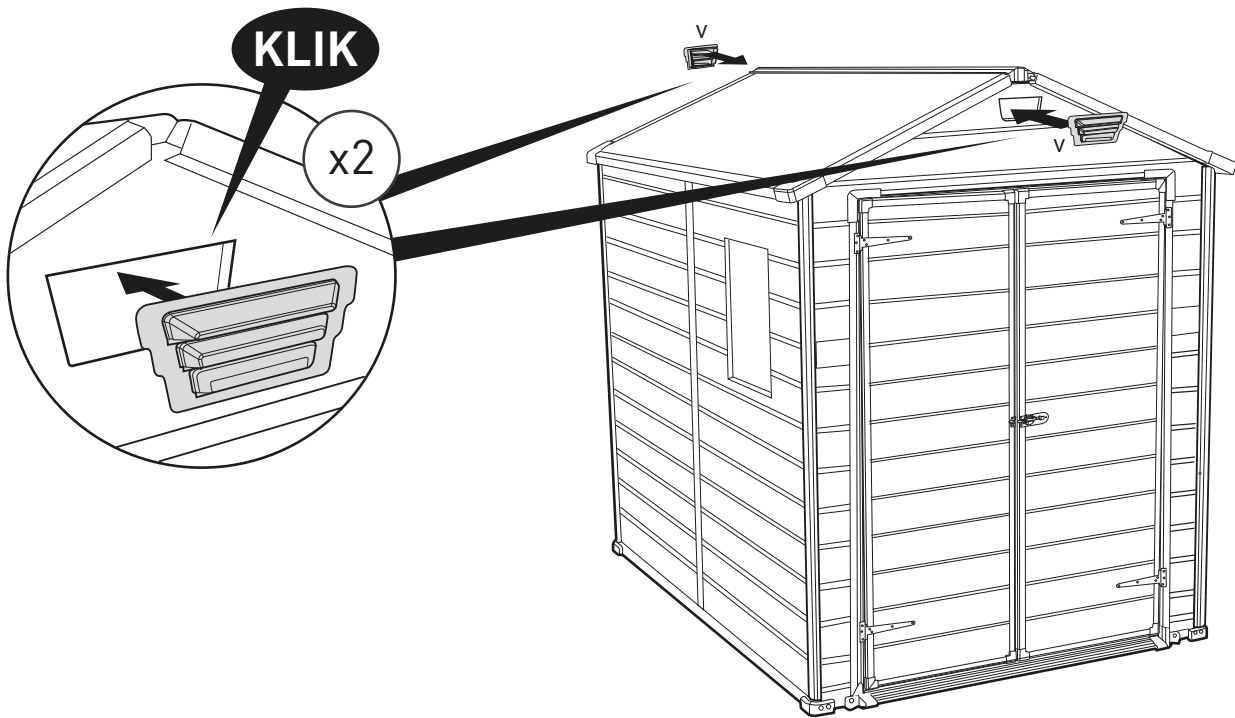
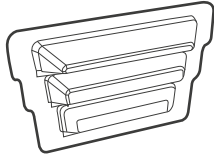

53

kc (x2)

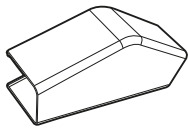

s26b (x4)
1"
26 mm

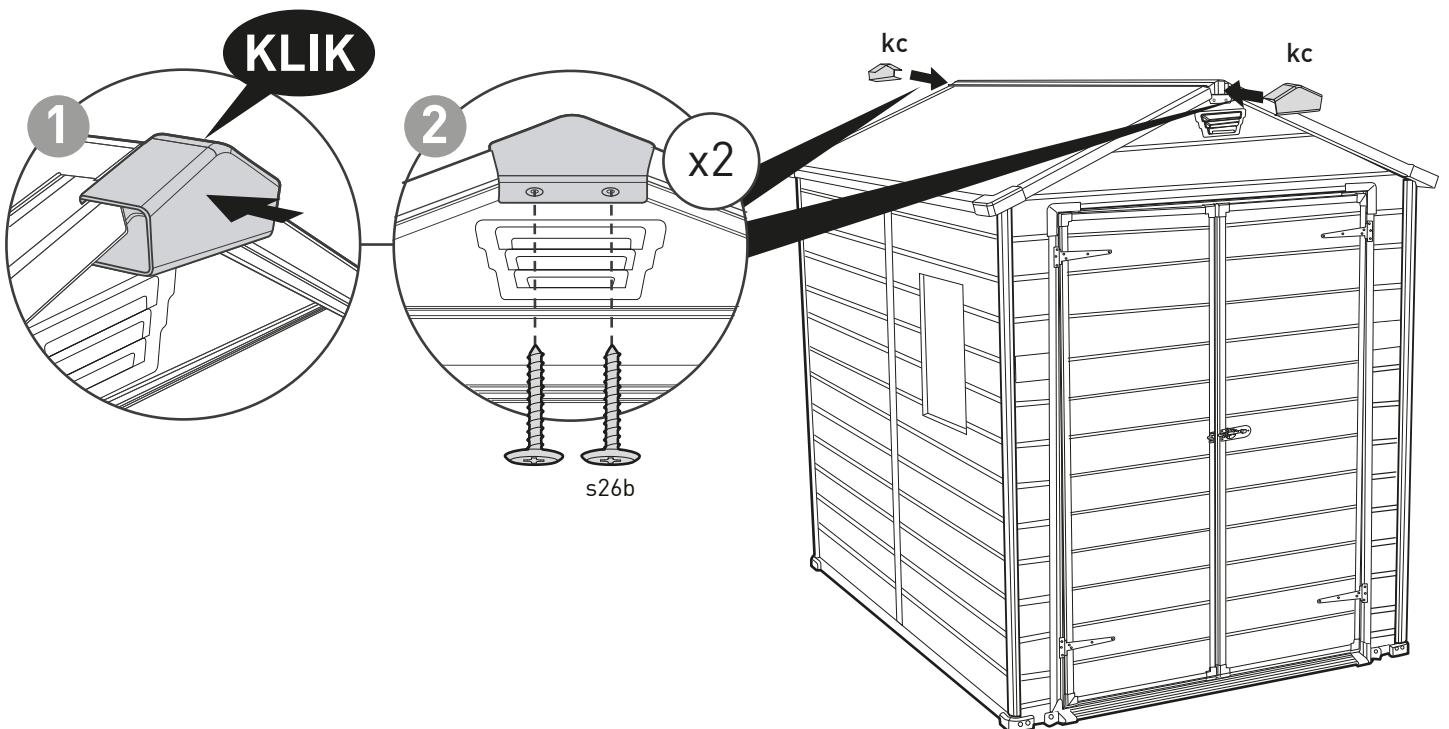
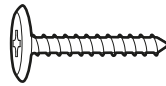

MONTAŽ OKNA

54 | f-out (x1) | pls (x1)

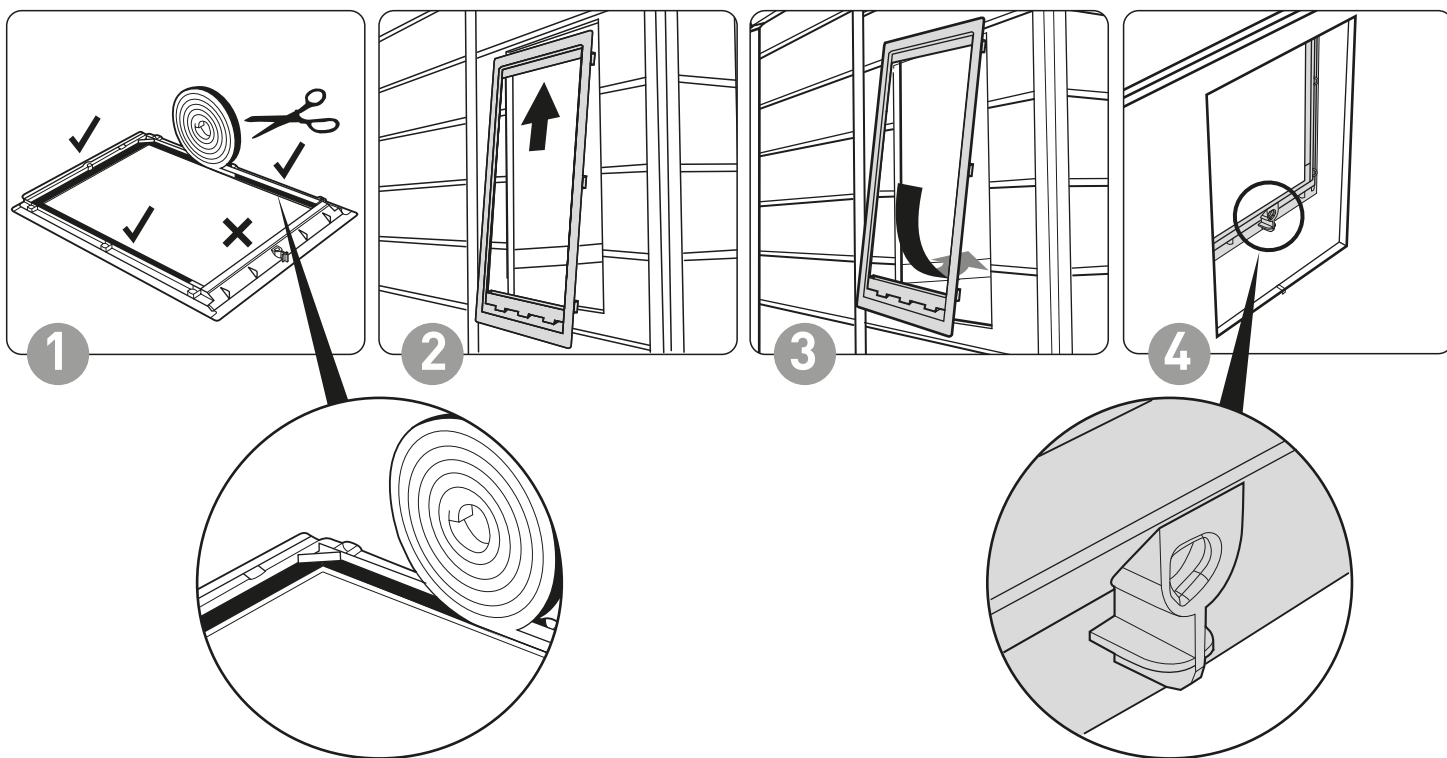

55 | acw (x1)

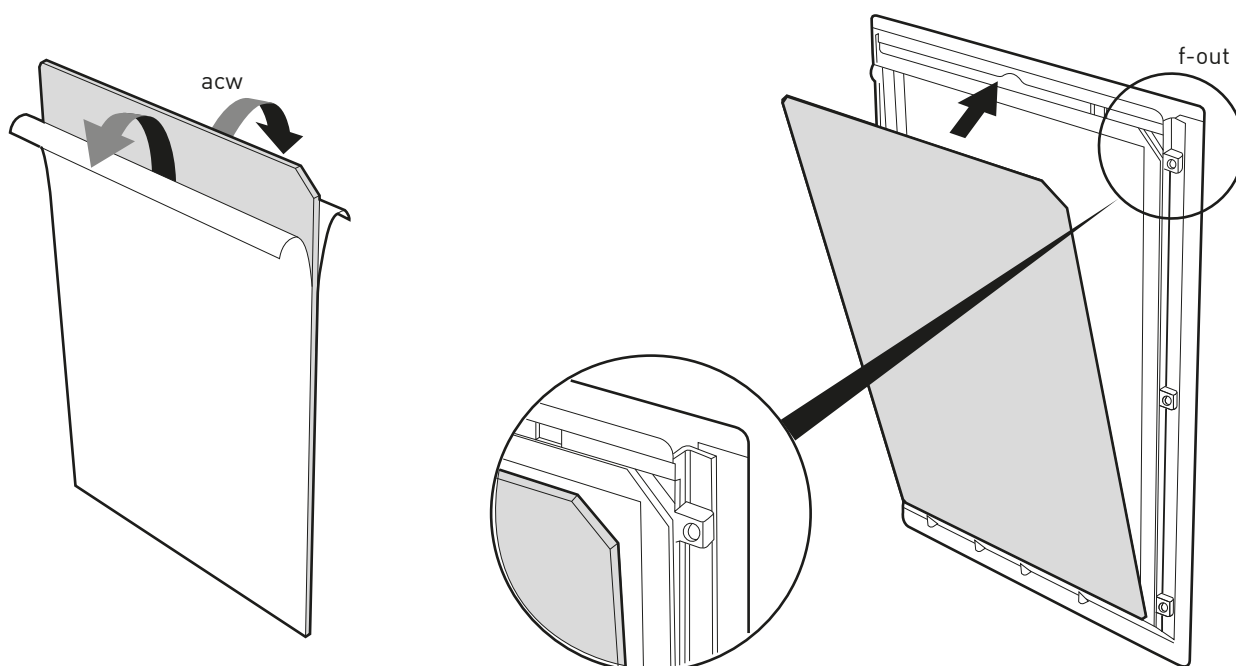
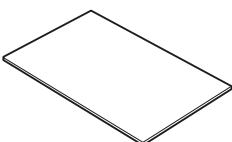

f-in (x1)



sc15 (x7)
0.63"
16 mm

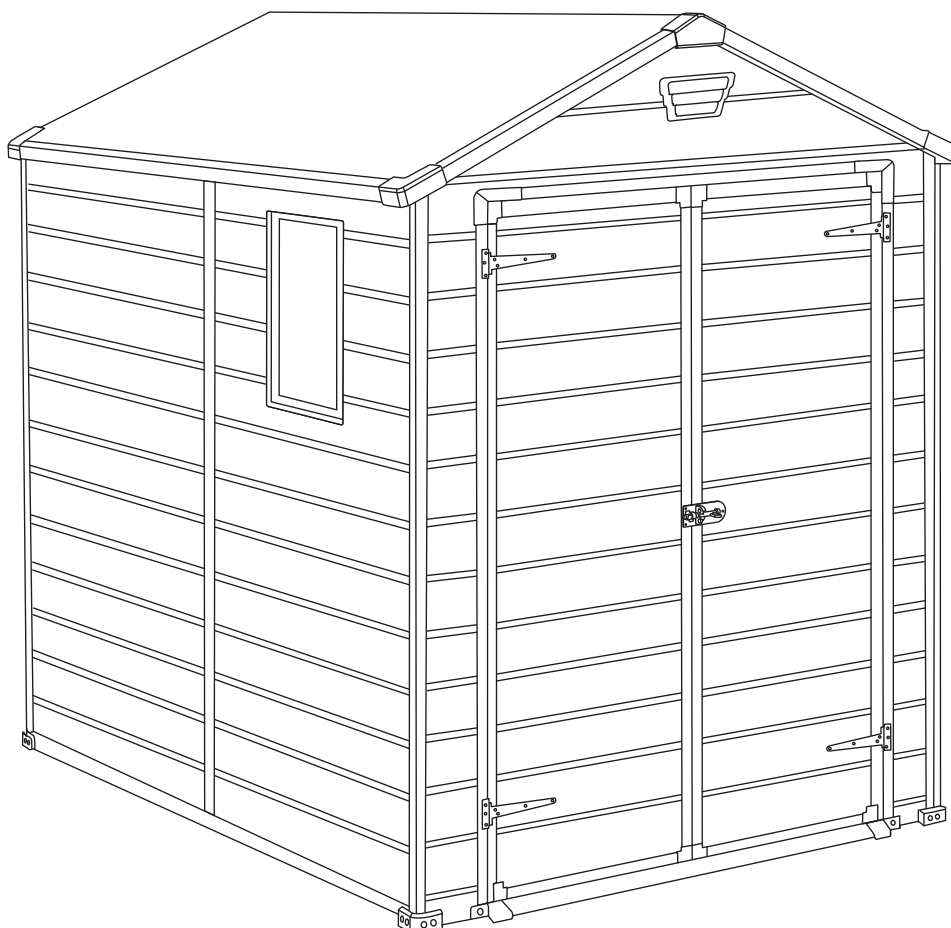
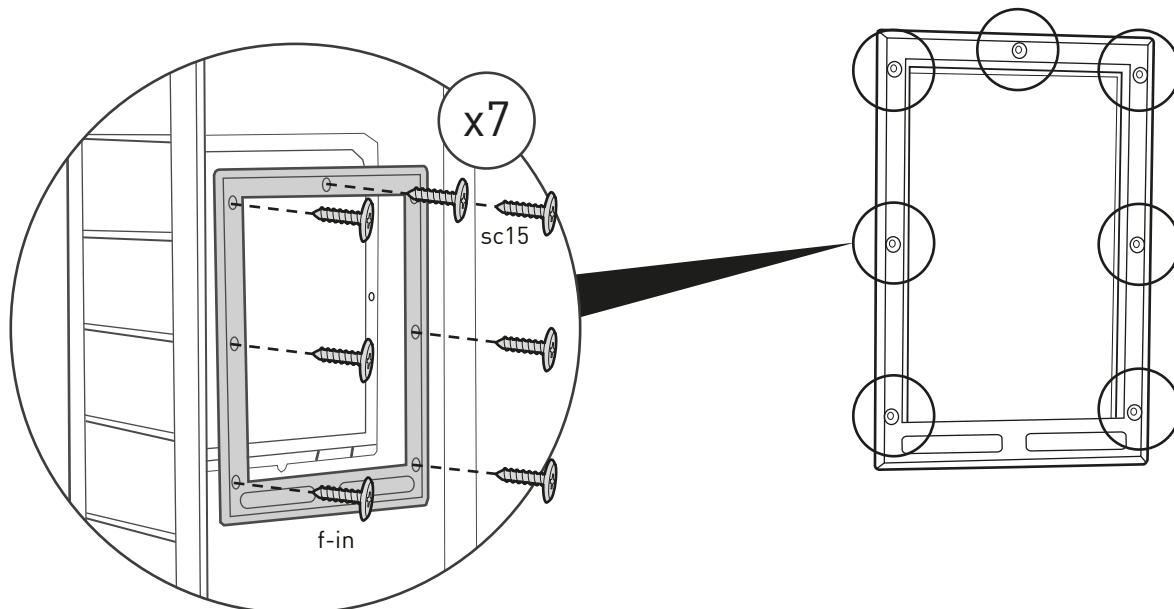
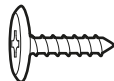

OPCJA – MOCOWANIE DOMKU NARZĘDZIOWEGO DO FUNDAMENTU

Zabezpiecz domek narzędziowy poprzez przykręcenie jego konstrukcji do podłoża w wyznaczonych w podłodze punktach, za pomocą odpowiednich śrub (brak śrub w zestawie).

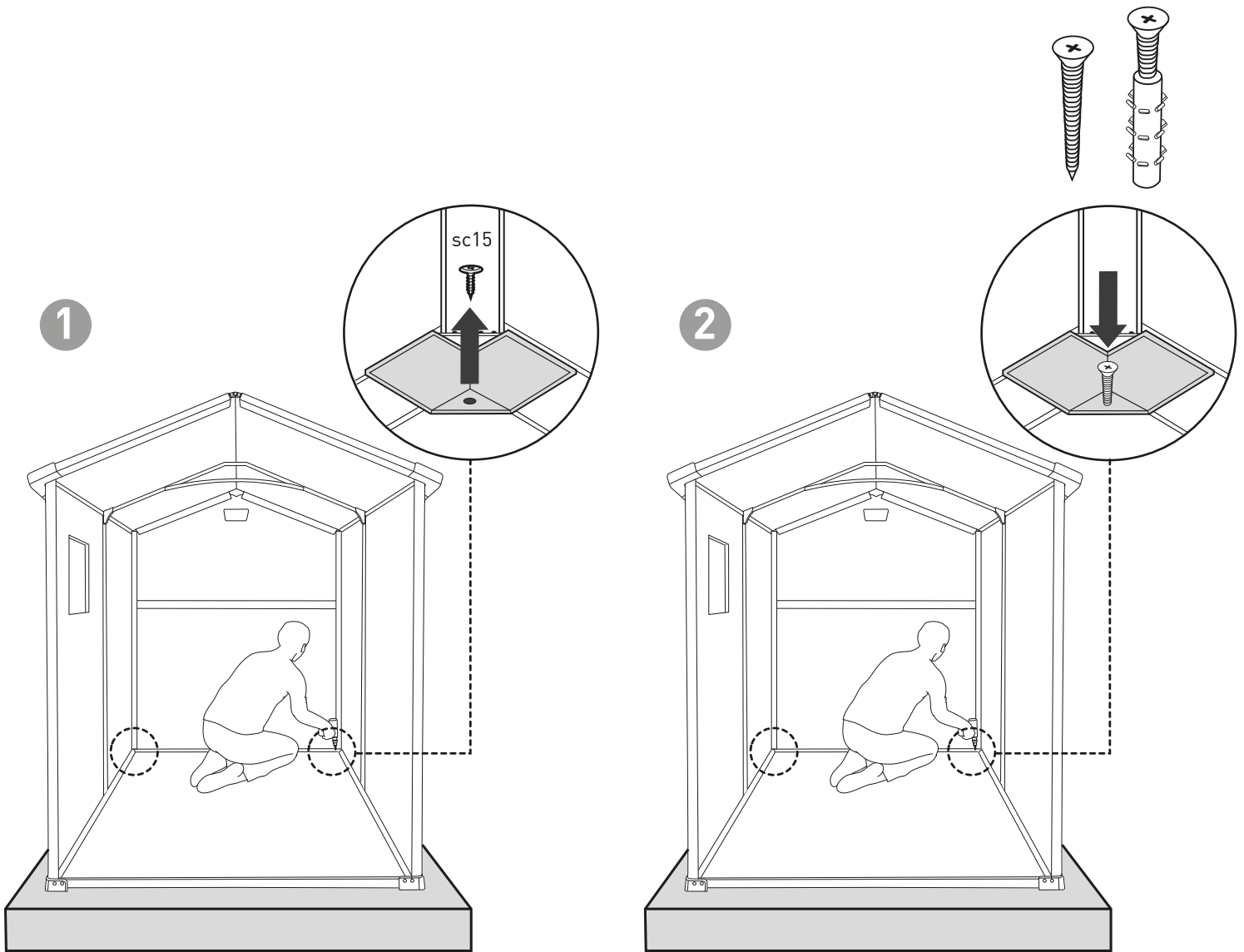



A series of horizontal lines for writing, consisting of 25 evenly spaced lines that span the width of the page.

ZASADY BEZPIECZNEGO UŻYTKOWANIA:

- Domek narzędziowy przeznaczony jest wyłącznie do przechowywania rzeczy. Nie jest przeznaczony do zamieszkania.
- Zaleca się zabezpieczenie domku narzędziowego poprzez przymocowanie konstrukcji do obiektów stałych lub przykręcenie go do podłoża w wyznaczonych w podłozdzie punktach, za pomocą odpowiednich śrub (brak śrub w zestawie).
- Nie wykonywać montażu przy silnym wietrze oraz w niskich temperaturach.
- Należy systematycznie sprawdzać stabilność domku oraz poziom gruntu, na którym jest on ustawiony.
- Należy uważać na metalowe krawędzie elementów domku narzędziowego.
- Podczas montażu lub w trakcie użytkowania należy używać tylko narzędzi wyszczególnionych w instrukcji obsługi.
- Przy montażu i konserwacji domku narzędziowego zawsze należy nosić rękawice robocze, okulary ochronne i długie rękawy.
- Należy unikać używania kosiarek lub kos mechanicznych w pobliżu domku narzędziowego.
- W trakcie używania narzędzi elektrycznych zawsze należy nosić okulary ochronne i postępować zgodnie z instrukcjami producenta.
- Domek narzędziowy należy myć przy użyciu węża ogrodowego lub łagodnych detergentów. Nie należy używać twardych szczotek lub silnych środków czystości, w tym odtłuszczaczy lub produktów na bazie oleju lub acetonu. Produkty te mogą trwale uszkodzić powierzchnię domku narzędziowego.
- Nie należy przechowywać w domku narzędziowym gorących przedmiotów takich jak rozgrzane grille, lutownice oraz jakichkolwiek lotnych substancji chemicznych.
- Należy unikać opierania ciężkich przedmiotów o ściany domku, ponieważ może to spowodować odkształcenia.
- Dach domku narzędziowego powinien być regularnie oczyszczany z nagromadzonego śniegu bądź liści. Duże ilości śniegu na dachu mogą uszkodzić domek narzędziowy i być niebezpieczne dla użytkowników domku.
- Ważnym czynnikiem przy określaniu lokalizacji dla domku narzędziowego jest siła i kierunek wiatru. Należy starać się, aby oddziaływanie wiatru na domek narzędziowy było stosunkowo małe, szczególnie od strony drzwi. Aby zapobiec uszkodzeniom wynikającym z oddziaływania wiatru – drzwi domku powinny być zawsze zamknięte, kiedy nie jest on używany.
- Nie stawać na dachu.
- Przed ustawieniem domku należy skonsultować się z lokalnymi urzędami, aby sprawdzić, czy nie są wymagane pozwolenia budowlane na postawienie domku narzędziowego.

OGRANICZONA – 10-LETNIA GWARANCJA

Domek narzędziowy firmy Keter, nazywany dalej jako „produkt”, wykonany został z wysokiej jakości materiałów sztucznych, nadających się do ponownego przetworzenia i recyklingu, a jego produkcja na każdym etapie była dokładnie nadzorowana i kontrolowana. W razie jakichkolwiek problemów z produktem, prosimy kierować swoje zastrzeżenia do Działu Obsługi Klienta dystrybutora produktu. Produkt od dnia zakupu objęty jest dziesięcioletnią gwarancją na wady fabryczne samego produktu lub materiałów, z których został on wykonany. Termin „wady” obejmuje wszelkie niedoskonałości, które uniemożliwiają korzystanie z produktu. Gwarancja nie obejmuje uszkodzeń wynikających z normalnego użytkowania produktu, w tym między innymi: powstałych w trakcie użytkowania rys lub pęknięć, przebarwień, rdzewienia, uszkodzeń powstałych w wyniku niewłaściwego wykorzystania produktu, zaniedbań, zmian konstrukcyjnych, malowania, przenoszenia, transportu lub przesuwania produktu oraz oddziaływania tzw. „sił natury” w tym, ale nie wyłącznie, gradu, burz, powodzi i pożaru oraz innych uszkodzeń przypadkowych lub celowych. Montaż oraz użytkowanie niezgodne z zaleceniami producenta opisanymi w instrukcji oraz wykorzystanie produktu do celów komercyjnych lub publicznych, powoduje unieważnienie gwarancji. Firma Keter nie ponosi odpowiedzialności za szkody poniesione przez osoby trzecie oraz za uszkodzenia lub utratę przedmiotów znajdujących się wewnątrz lub w pobliżu domku narzędziowego. Po przedstawieniu zgłoszenia reklamacyjnego wraz z paragonem/rachunkiem stanowiącym dowód zakupu oraz po uznaniu i uregulowaniu ewentualnego roszczenia okres gwarancji będzie wciąż liczony i uptynie z dniem jej wygaśnięcia.

UWAGA! W przypadku stwierdzenia braku lub uszkodzenia części przed montażem, prosimy nie zwracać produktu, tylko skontaktować się z Działem Obsługi Klienta dystrybutora produktu.

Producent: Keter Plastic Ltd, 2 Sapir St. Industrial Area, Herzelia, Israel 46852

Dystrybutor: CURVER Poland Sp. z o.o., ul. Wrocławska 34, 76-200 Stupsk, Polska;
CURVER Hungary, Zsong Volgy 2, H-4211 Hungary

www.curver-lifestyle.pl

www.curver-lifestyle.com

ОФИЦИАЛЬНЫЙ ДИЛЕР В УКРАИНЕ:

storgom.ua

ГРАФИК РАБОТЫ:

Пн. – Пт.: с 8:30 по 18:30

Сб.: с 09:00 по 16:00

Вс.: с 10:00 по 16:00

КОНТАКТЫ:

+38 (044) 360-46-77

+38 (066) 77-395-77

+38 (097) 77-236-77

+38 (093) 360-46-77

Детальное описание товара: <https://storgom.ua/product/keter-164476.html>

Другие товары: <https://storgom.ua/sadovye-sarai.html>